





TEACHER MANUAL – 3D WORLD OF CHEMISTRY

1) INTRODUCTION TO THE SUBJECT

The subject is based on the latest approaches and teaching techniques, and the digitalization of the teaching process brings students closer to the teaching content. The learning process is more dynamic and interactive, and students are given a completely different insight into the chemical processes that will "come to life" in 3D by using the *ChemSketch* program. As part of getting to know the work in the program, students will get to know all the possibilities offered by the *ChemSketch* program, learn to use the key functions provided by the program on examples of structures of different organic compounds. Also, students will use the program to display equipment and laboratory apparatus, which is especially useful for students when writing laboratory journals during regular chemistry classes.

2) DESCRIPTION OF THE TOOLS USED – *ChemSketch*

- The *DrawNormal* tool is the default tool when the program is started. With this tool active, you can easily draw normal or branched chains and replace the drawn atoms with other atoms from the Periodic Table of Elements.
- The *DrawContinuous* tool is very convenient for "sprouting" new atoms. Note that with this tool active, you can draw bonds from the selected atom only.
- Drawing double and triple bonds – by pointing to the last drawn bond (you will see a rectangle around the bond), and then clicking it to make a double bond. By clicking one more time we can draw a triple bond.
- Canceling actions - This will cancel the last action performed and reset the workspace to exactly what it was before your last change.
- Deleting individual atoms - With the *Delete* tool () active, click the atom you want to delete from the structure.

- Changing atoms - To replace an atom with a new element whose button is not displayed on the Atoms toolbar
- Drawing bond between two atoms - When either *DrawNormal* () or *DrawContinuous* () tool is selected, dragging from one atom to another draws a single bond between them.
- "Cleaning" structure – to "clean" the drawn structure by standardizing all the bond lengths and angles
- Editing atom labels - The *Edit Atom Label* tool () allows you to substitute terminal atoms with shorthand abbreviations.
- Rotating structural fragments.
- Drawing chains - Using the *DrawChains* tool (), you can easily draw chains of any length simply by dragging.
- Setting charges and defining anions and cations.
- Cleaning workspace - If you want to clean the workspace in order to draw your structures from scratch.

3) ELABORATION OF SELECTED CHAPTERS

Teaching unit: Introduction
Unit title: Basics of Working in the <i>ChemSketch</i> Software
Estimated number of hours: 2

4.1. Theoretical introduction to the chapter

As a part of this chapter, students will learn the basic tools needed to work in the *ChemSketch* program. Knowledge of these tools is necessary for achieving educational outcomes of all subsequent teaching units. Students will learn to draw simple examples of the structures of organic compounds, go through different toolbars (general, atom, structure toolbar) and learn different options that *ChemSketch* program can offer.

4.2. Educational outcomes of the selected chapter

In this chapter, students will learn how to:

- use the tools available in the *ChemSketch* program to draw the desired molecules of organic compounds,
- display the structure of molecules of organic compounds in three dimensions using the *3D Viewer* option,
- use tools for marking parts of a molecule or the whole molecule, tools for rotating molecules and moving molecules in 2D and 3D,
- draw a hydrocarbon chain using the options *DrawNormal*, *DrawContinuous*, *DrawChains*,
- delete parts of the molecule structure or the entire molecule using the *Delete* option,
- draw a double and triple bond in a compound,
- add alkyl groups to the existing compound and change the types of atoms in the structure of the molecule,
- cancel changes made in the program,
- optimize the structure of the molecule,
- draw the structures of anions and cations using the charge generation tool.

4.3. Instructions for using the *ChemSketch* software for the selected chapter

a) Using Draw Normal tool:

The *DrawNormal* tool () is the default tool when the program is started. With this tool active, you can easily draw normal or branched chains and replace the drawn atoms with other atoms from the Periodic Table of Elements.

Example 1 Draw 2-methylpropane and 2-methylbutane by using the Draw Normal tool. Rotate the drawn structure vertically.

Make sure that the *DrawNormal* tool is enabled on the *Structure toolbar* and that the Carbon button () is selected on the *Atoms toolbar*.

STEP 1 Click on an empty space to draw methane CH₄.

STEP 2 Point to CH₄ and, when you see a rectangle around the methane formula (**figure 1**), click it to add a methyl group thus creating ethane H₃C—CH₃.



Figure 1 Rectangle around the methane formula.

STEP 3 Click twice one of the CH₃ groups to draw 2-methylpropane shown in **figure 2**.

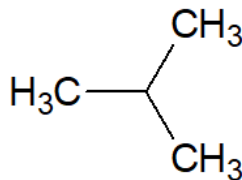



Figure 2 Structure of 2-methylpropane

STEP 4 On the *Structure toolbar*, click *Set Bond Vertically* () and then click the lower bond of the structure to rotate it vertically as shown in **figure 3**.

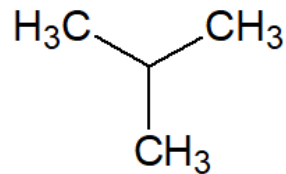



Figure 3 Vertically rotated structure of 2-methylpropane

STEP 5 On the *Structure toolbar*, click *DrawNormal* () and then click the rightmost carbon atom to draw 2-methylbutane (**figure 4**).

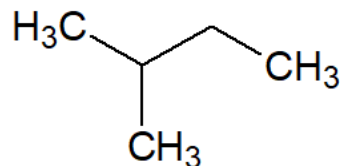

Figure 4 Structure of 2-methylbutane

Note: The hydrocarbon chain will be enlarged each time you click the rightmost carbon atom. To extend the chain horizontally, press CTRL when clicking the atom.

Drawing double and triple bonds:

Example 2 Draw 3-methyloct-1-ene and 3-methyloct-1-yne by using the *DrawNormal* tool.

STEP 1 Draw 3-methyloctane structure (**figure 5**) and then point to the single bond between the first two carbon atoms from the hydrocarbon chain (you will see a rectangle around the bond), and then click it to make a double bond (**figure 6**).

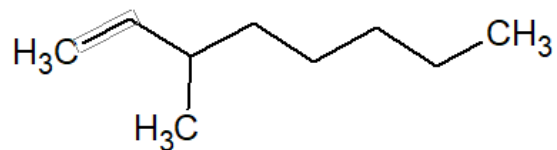

Figure 5 Rectangle around the single bond between the first two carbon atoms from the hydrocarbon chain.

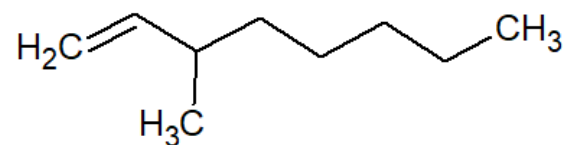



Figure 6 Structure of 3-methyl-1-octene

STEP 2 Click again to make a triple bond. Select the whole structure by clicking at the icon  and dragging around the whole structure. Then, click *Tools* and then choose the option *Clean Structure* as shown in **figure 7a** and **figure 7b**.

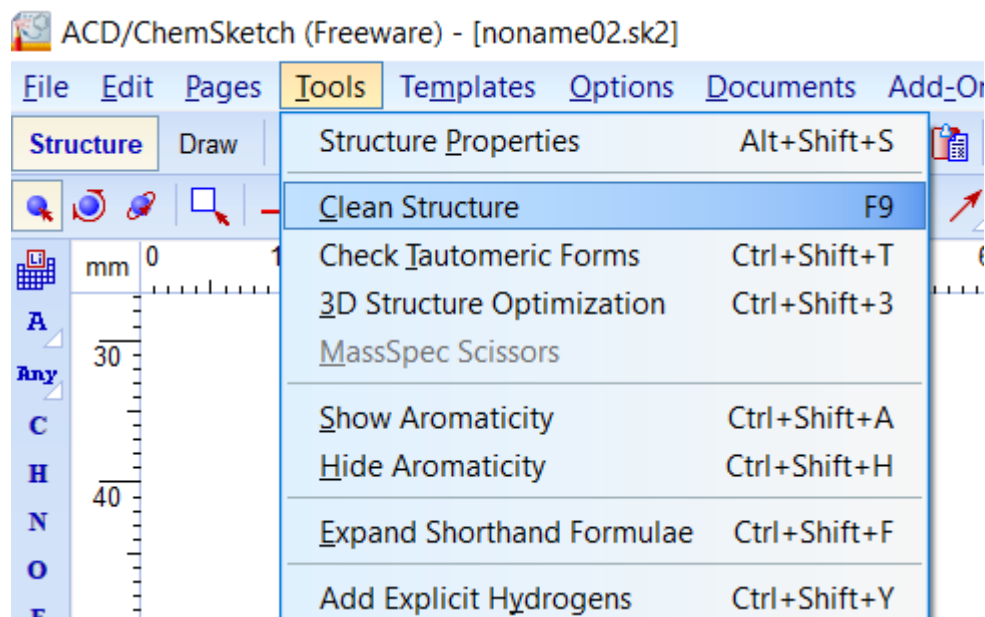
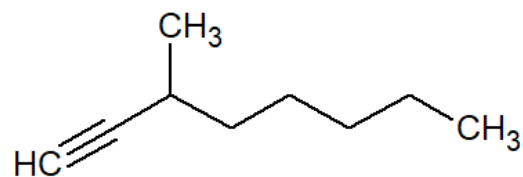

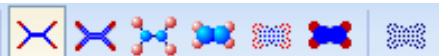



Figure 7 a) Cleaning structure option



b) Structure of 3-methyl-1-octyne

STEP 3 By clicking on the *3D Viewer* option () , display the structure of the 3-methyl-1-octyne molecule in three dimensions.

STEP 4 Try using each of the *Rotate*, *Move*, and *Label the molecule* options located on the top toolbar: , and then display the molecule in each of the ways the program offers, the options are also displayed on the toolbar: .

Clicking on any of the options changes the way the 5-ethyl-2,2-dimethylheptane molecule is displayed. For automatic rotation of the molecule, click on the icon . For automatic continuous change from one to another mode of displaying the molecule with rotation, click on the icon .

Deleting individual atoms:

Example 3 Use the drawn structure of 3-methyloct-1-yne from the example 2 and remove the methyl-group from the structure by using the *Delete* tool. Then reverse all the changes made on that structure.

STEP 1 On the *General toolbar*, click *Delete* (). With the *Delete* tool active, click on the carbon atom from the methyl-group. Name the resulting compound shown in **figure 8**.

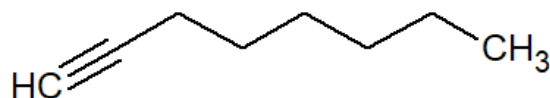

Figure 8 Structure of _____

STEP 2 On the *General toolbar*, click *Undo* () to reverse the changes.

Additional tools:

STEP 3 Use the *Delete* tool again, but now click the last but one carbon atom of the main chain. Note that the whole ethyl-group is removed from the 3-methyloctane structure. Name the resulting compound shown in **figure 9**.

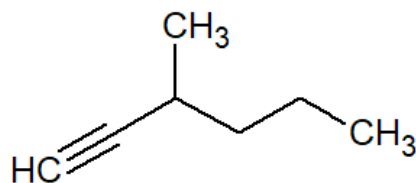

Figure 9 Structure of _____

STEP 4 Reverse all changes and when you again have 3-methyloct-1-yne, choose the *Delete* tool and now holding down *CTRL*, click the same carbon atom again. As you can see in **figure 10**, the last but one atom is removed while the terminal atom of the main chain attached to the deleted one is now retained on the page.

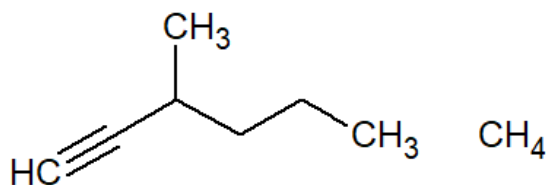



Figure 10 Combining *CTRL* and *Delete* tool together to delete the last but one carbon from the structure of 3-methyloct-1-yne.

STEP 5 Click *Undo* () to reverse the changes and return to the 3-methyloctane structure.

Changing atoms:

Example 4 Replace the carbon atom from the methyl-group of 3-methyloctane with fluorine atom.

STEP 1 On the *Atoms toolbar*, click *Periodic Table* () to display the Periodic Table of Elements dialog box.

STEP 2 In the *Periodic Table of Elements*, click *Fluorine*, and then click OK. Note that the *Fluorine* button is now active on the *Atoms toolbar*.

Click the carbon atom from the methyl-group to replace it with the fluorine atom to get a structure shown in **figure 11**. Name that compound..

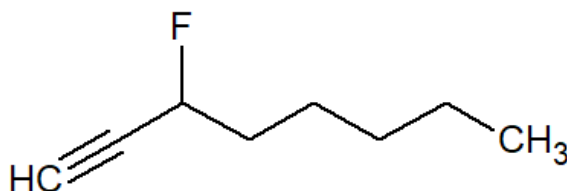



Figure 11 Structure of _____

Note:

When you select elements from the *Periodic Table of Elements*, the corresponding buttons are automatically added to the *Atoms toolbar*. To remove these buttons from the *Atoms toolbar*, right-click the *Atoms toolbar*, and choose *Reset Toolbar* from the shortcut menu. In the message box that appears, click *Yes*. This will remove all the user-defined element buttons except the default ones.

b) Using *DrawContinuous* tool:

With this tool active, you can draw bonds from the selected atom only.

STEP 1 On the *Structure toolbar*, click (*DrawContinuous* ). Alternatively, you can press the right mouse button to switch on the *DrawContinuous* tool.

STEP 2 Ensure that the *Fluorine* button (Fluorine) is still selected on *the Atoms toolbar*. Click the rightmost carbon atom in the previously drawn structure (view **figure 12**) to highlight it:

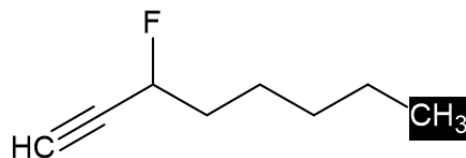

Figure 12 Highlighted last carbon atom in a structure

STEP 3 Click again to sprout fluorine from the selected carbon atom. Repeat steps 2–3 for the same carbon atom to sprout up the second fluorine atom (**figure 13**). Name the compound that you got.

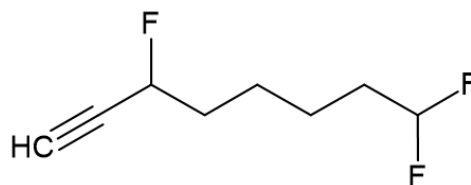

Figure 13 Structure of _____

Drawing bonds between atoms and "Cleaning" structure:

Example 5 Draw a single bond between terminal carbon atoms in a structure of 1,1,3-trifluorohexane and then "Clean" that structure. To "clean" the drawn structure means standardizing all the bond lengths and angles.

STEP 1 Use the *DrawContinuous* tool and draw 1,1,3-trifluorohexane.

STEP 2 Dragging from one atom to another draws a single bond between them. With the *DrawContinuous* tool active (or draw normal as well), point to a terminal carbon and drag to another terminal carbon to get a single bond between those carbon atoms (**figure 14**).

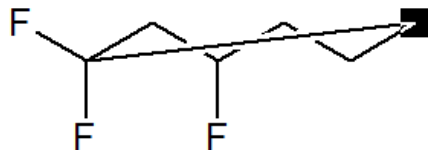

Figure 14 Dragging from one terminal carbon to another to draw a single bond between them

STEP 3 From the *Options menu*, choose *Preferences*, and then, on the *Clean* tab of the *Preferences* dialog box that appears, set the same options as shown in the **figure 15**.

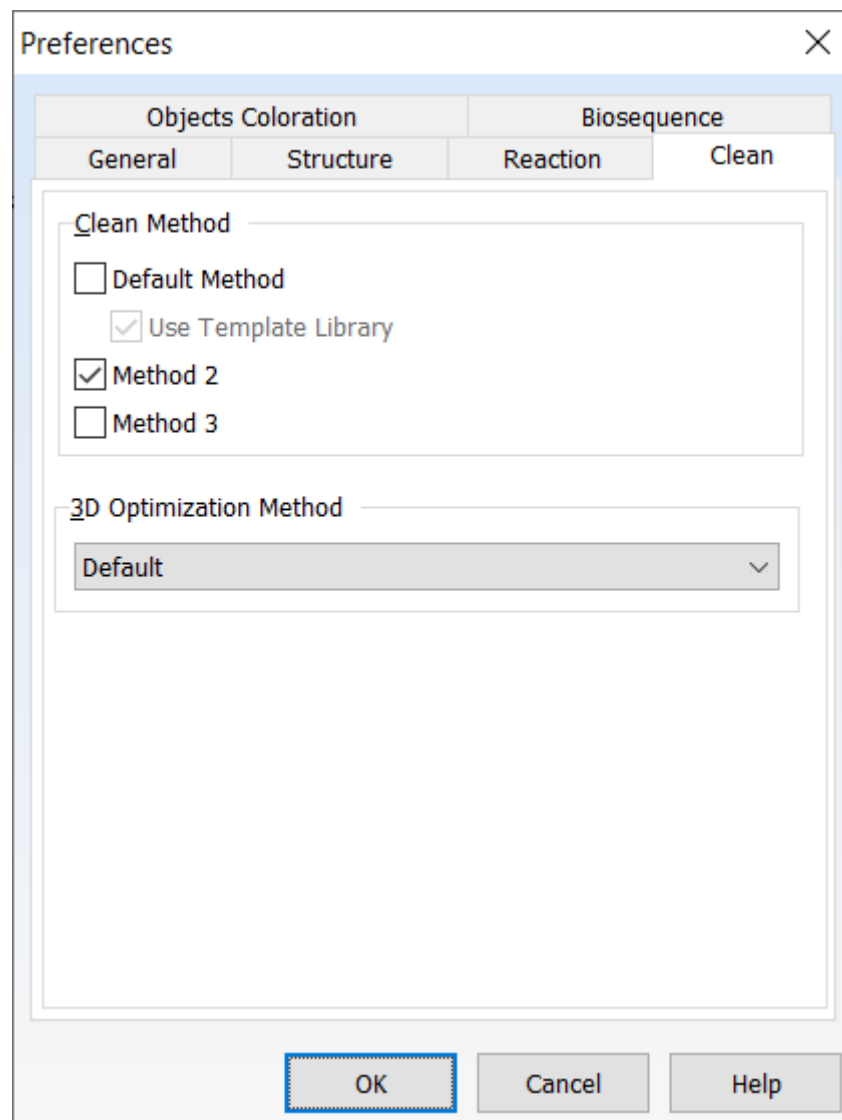

Figure 15. Setting options for “cleaning” structures

STEP 3 Click *OK* to close the dialog box. On the *Structure toolbar*, click *Clean Structure* (). If you have done everything right, you should get a structure shown in **figure 16**. Name the compound.

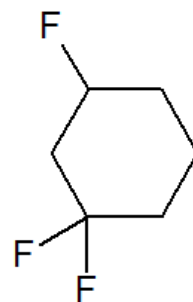



Figure 16 Structure of _____

STEP 4 On the *Structure toolbar*, click *Set Bond Vertically* () , and then click the carbon-fluorine bond to rotate the structure (**figure 17**).

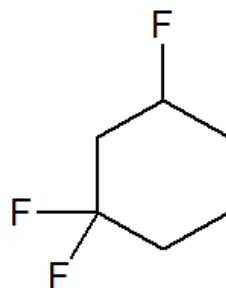



Figure 17 Vertically rotated structure of _____

Editing atom labels:

Example 6. Substitute the fluorine atom from the structure shown in **figure 17** with $(\text{CH}_2)_2\text{Ph}$ group and expand that notation.

The *Edit Atom Label* tool () allows you to substitute terminal atoms with shorthand abbreviations.

Using the structure cleaned in the previous section, perform the following steps:

STEP 1 On the *Atoms toolbar*, click *Edit Atom Label* () , and then click the lowermost fluorine atom on the drawn structure.

STEP 2 In the *Edit Label* dialog box that appears, type $(\text{CH}_2)_2\text{Ph}$, and click *Insert*. Note that the label is inserted in the desired position and the indexes are automatically subscripted. The structure you should get by inserting that label is shown in **figure 18**. Name that compound.

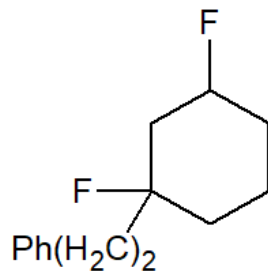

Figure 18 Structure of _____ got by inserting the wanted new label in the desired position.

STEP 3 On the *Structure Toolbar*, click *Change Position* () , and then click the label to invert it as shown in **figure 19**.

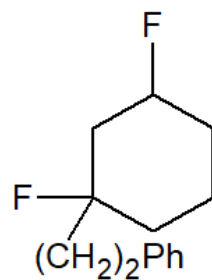



Figure 19 Inverted label of previous structure (shown in **figure 18**)

Tip:

If you hold down *SHIFT* and click the label with the *Change Position* tool active, the connection point of the label will be changed.

STEP 4 Click *Edit Atom Label* () and, with the *Edit Atom Label* tool active, click the resulting shorthand abbreviation. In the *Edit Label* dialog box, click *Expand* to obtain the structure shown in **figure 20**.

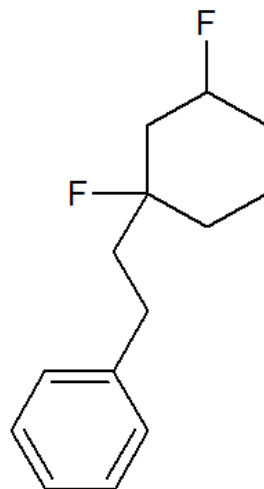

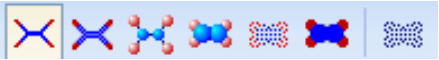



Figure 20 Expanded label of structure shown in **Figure 19**.

STEP 5 By clicking on the *3D Viewer* option () , display the structure of the obtained molecule in three dimensions.

STEP 6 Try using each of the rotate, move, and label the molecule options located on the top toolbar:  , and then display the structure of molecule in each of the ways the program offers, and the options are also displayed on the toolbar:  .

Clicking on any of the options changes the way the structure of the molecule is displayed. For automatic rotation of the molecule, click on the icon  . For automatic continuous change from one to another mode of displaying the molecule with rotation, click on the icon  .

Important:

Only the group abbreviations that substitute labels of terminal atoms can be expanded by using the *Expand* button (*Expand*).

Drawing chains

Using the *DrawChains* tool () , you can easily draw chains of any length simply by dragging.

Example 7. Draw the structure of 1,1-diethyl-3-propylcyclopentane by using the *DrawChain* tool.

STEP 1 Draw cyclopentane and then on the *Structure toolbar*, click *DrawChains* () , and point to the first carbon atom that needs to contain two ethyl-groups (based on the name of the compound). Drag left to create a carbon chain until the carbon counter located beside the mouse pointer reaches C2. Note that the counter changes with each carbon added (when dragging forth) or removed (when dragging back). Repeat the same procedure to draw another ethyl group on the first carbon atom and to draw one methyl group on the third carbon atom. “*Clean*” that structure. You should get the structure shown in **figure 21**.

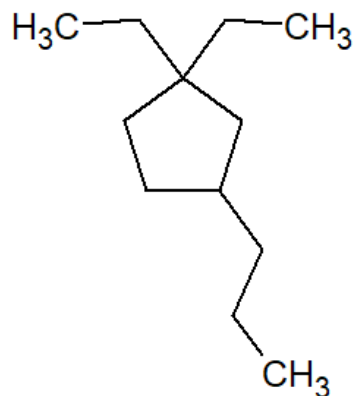



Figure 21 Structure of 1,1-diethyl-3-propylcyclopentane

Tip:

When dragging, the chain bonds are set at an angle of 120° to each other. To set the bonds at an angle of 180°, holding down *CTRL* while dragging.

STEP 2 With the *DrawChains* tool () still active, on the *Atoms toolbar*, click *Fluorine* () , and then click the third carbon from the propyl group three times to sprout three fluorine atoms (**figure 22**).

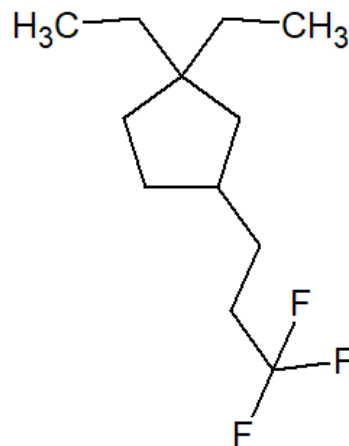



Figure 22 Adding fluorine atoms to the structure shown in **figure 21**.

STEP 3 On the *Structure toolbar*, click *Select/Move* () , then select the three fluorine atom bonds, and click *Clean Structure* () . The resulting structure is shown in **figure 23**. Name the structure.

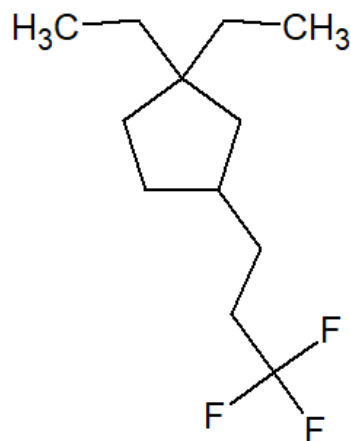

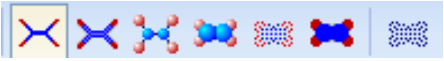



Figure 23 Structure of _____

STEP 4 By clicking on the *3D Viewer* option () , display the structure of the obtained molecule in three dimensions.

STEP 5 Try using each of the rotate, move, and label the molecule options located on the top toolbar:  , and then display the structure of molecule in each of the ways the program offers, and the options are also displayed on the toolbar: .

Clicking on any of the options changes the way the structure of the molecule is displayed. For automatic rotation of the molecule, click on the icon  . For automatic continuous change from one to another mode of displaying the molecule with rotation, click on the icon .

Setting charges and defining anions and cations:

Example 8. Draw the structure of butane and then replace the second carbon atom with nitrogen atom. Use *Charges/Radicals* set of tools from the *Atom toolbar* to change charge on nitrogen or to form radical.

STEP 1 On the *Atoms toolbar*, click Carbon (make sure that the *DrawNormal* tool () is active), and then click four times the same point of the workspace to draw the butane structure shown in **figure 24**.

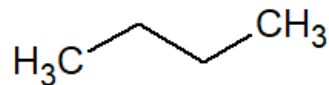

Figure 24 Structure of butane.

STEP 2 On the *Atoms toolbar*, click *Nitrogen*, and then click the second carbon atom (from left to right) to replace it with the nitrogen one as shown in **figure 25**.

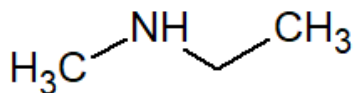



Figure 25 Structure of N-methylethanamine

STEP 3 Add to the workspace five more duplicates of our N-methylethanamine structure. You can do that in the following way: select the created structure by clicking an empty space in the drawing area near it. Press *CTRL+C* to copy it to the *Clipboard*. Paste the required number of copies by pressing *CTRL+V* and clicking in the workspace.

STEP 4 On the *Atoms toolbar*, click the lower right triangle of () to expand the *Charges/Radicals* set of tools.

STEP 5 Choose the *Decrement (-) Charge tool* () (note that the mouse pointer turns into Cursor), and then click the NH group of the first structure to make it a ethylmethylanide anion (**figure 26**).

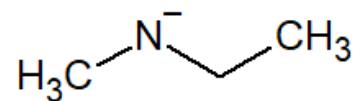



Figure 26 Structure of ethylmethylanide anion.

STEP 6 Right-click within the workspace to quickly switch to the *Increment (+) Charge* tool () (the mouse pointer turns into *Cursor*), and then click the NH group of the second structure to make it an N-methylethanaminium cation (**figure 27**).

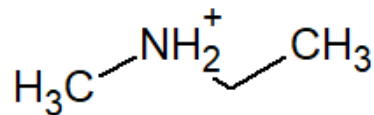

Figure 27 Structure of N-methylethanaminium cation

Note:

When using the *Increment (+) Charge* or *Decrement (-) Charge* tools, the proper chemical valence of a non-metal atom is preserved by automatically adding or removing hydrogen atoms. If you change the charge of a metal atom, it is changed in increments or decrements in accordance with the next chemically valid charge of the corresponding ion. Common valences can be found in the *Periodic Table of Elements* dialog box.

STEP 7 From the *Charges/Radicals* tools, choose *Radical* (the mouse pointer turns into *Cursor*), and click the NH group of the third structure to draw a free ethylmethylanin radical (**figure 28**)

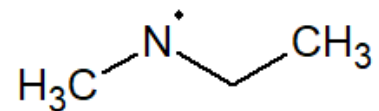

Figure 28 Structure of ethylmethylamin radical

STEP 8 Right-click within the workspace to quickly switch the mouse pointer to Cursor, and click the NH group of the fourth structure to draw the dimethylamin radical cation (**figure 29**)

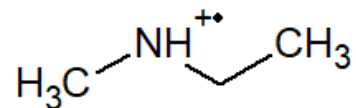

Figure 29 Structure of ethylmethylamin radical cation

STEP 9 Next right-click within the workspace will switch the mouse pointer to *Cursor*; click the NH group of the fifth structure to draw the dimethylamin radical anion (**figure 30**).

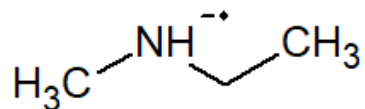

Figure 30 Structure of ethylmethylamin radical anion

Cleaning workspace:

If you want to clean the workspace in order to draw your structures from scratch, use one of the following ways:

Example: Create a new blank *ACD/ChemSketch* document:

STEP 1 On the *General toolbar*, click *New Document*; or

STEP 2 From the *File* menu, choose *New*.

Example: Add a new blank page to the current *ACD/ChemSketch* document:

STEP 1 On the *General toolbar*, click *New Page*; or from the *Pages* menu, choose *New*.

Example: Clean up an active page within the current *ACD/ChemSketch* document:

STEP 1 From the *Edit* menu, choose *Select All*, and then, from the *Edit* menu, choose *Delete*; or

STEP 2 Press *CTRL+A* to select all the objects on the page, and then press *Delete*; or on the *General toolbar*, click *Delete*, click an empty space away from the drawn structures to select all of them, and then click the selection.

4.4. Examples of tasks for processing teaching content

For training purposes, let us repeat the above steps and draw some structures.

Task 1 Using the skills learned in *ChemSketch*, draw the shown structure of 3-methylheptane.

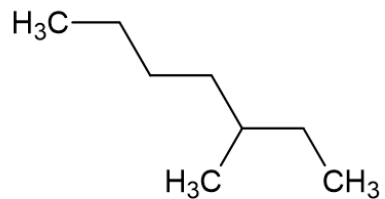

Task 2 Write the condensed structural formulas of the above-mentioned compounds:

- 2,2-dimethylbutane,
- 2-methylpentane.

Task 3 Draw the following structural formula of the compound, then replace one hydrogen atom of your choice with fluorine atom.

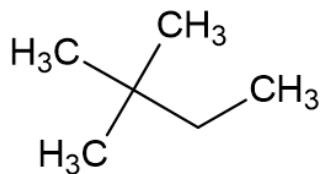

Task 4 a) Draw the following structure of alkane. Name that compound and add a triple bond between the third and fourth carbon atom. Name the resulting compound.

b) Delete methyl-group from the compound and by using the *DrawChains* tool add three more carbon atoms to the longest hydrocarbon chain so that the triple bond is between the first and second carbon atom.

c) Add phenyl group to the third carbon atom.

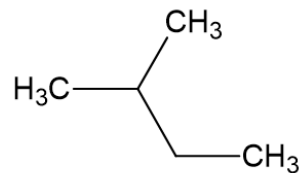

Task 5 In the previous example, use the double link function.

4.5. Examples of student evaluation tasks

TASK 1

- A) Using the skills acquired in *ChemSketch*, draw the structure of an alkane that contains 7 carbon atoms.
- B) Add a methyl group to the third carbon atom in the structure. Name the structure.
- C) Add a double bond between the third and fourth carbon atom in the structure. Name the structure.
- D) Replace the carbon atom from the methyl-group located on the third carbon atom in structure with a bromine atom. Name the structure.
- E) Substitute the bromine atom from the structure with CN group. Name the structure.
- F) Use the *Draw Continuous* tool to draw the cyclic form of the compound from the subtask. Name the structure.

TASK 2

- A) Draw a pentane and replace the second carbon atom with an oxygen atom.
- B) Make a cation, anion and radical of this structure by changing the charge on the oxygen atom. Name that anion, cation and radical.

ALKANES AND CYCLOALKANES

1.) ELABORATION OF THE UNIT TITLE

Teaching Unit: Hydrocarbons
Unit Title: Alkanes and Cycloalkanes
Estimated number of hours: 3

1.1. Theoretical introduction

a) Alkanes

- Alkanes are the simplest group of organic compounds.
- They are made of carbon and hydrogen atoms interconnected by single covalent bonds (the length of carbon-carbon bond is around 1.54 Å).
- Alkanes are saturated hydrocarbons because in their structure they contain only single covalent bonds between carbon atoms and because in their structure they form the maximum possible number of bonds with hydrogen atoms.
- The general formula of alkane is: C_nH_{2n+2} , where n represents the number of carbon atoms.
- The name of the alkane consists of the root of the word, which is formed on the basis of the Greek number (except for the first four alkanes) and the suffix *-ane*.

A series of straight-chain and unbranched alkanes whose adjacent members differ by one methylene group (-CH₂-) is called a homologous series of alkanes.

Table 1 shows the homologous series of alkanes.

Table 1. Names and molecular formulas of the first ten alkanes in the homologous sequence.

Name of Alkane	methane	ethane	propane	butane	pentane	hexane	heptane	octane	nonane	decane
Molecular formula	CH ₄	C ₂ H ₆	C ₃ H ₈	C ₄ H ₁₀	C ₅ H ₁₂	C ₆ H ₁₄	C ₇ H ₁₆	C ₈ H ₁₈	C ₉ H ₂₀	C ₁₀ H ₂₂

- If the alkane contains a branched chain of carbon atoms, the name is determined according to the longest chain.
- If the alkane contains two chains with the same number of carbon atoms, the name is determined according to the chain on which a greater number of substituents is attached (atomic group or atom attached to the main (longest) hydrocarbon chain).
- An alkyl group or alkyl is a hydrocarbon group that has an alkane structure with one less hydrogen atom and has the suffix **-YL**. It is usually denoted with the letter R.
- The carbon atom to which the alkyl group is attached is indicated by a number or a locant that must be as small as possible.
- If a hydrocarbon contains several of the same alkyl groups, their number is indicated by objects (di-, tri-, tetra-, etc.) that do not enter into the classification of substituents in alphabetical order.
- If there are several of the same numbering methods, the numbering direction is selected in alphabetical order.

EXAMPLE:

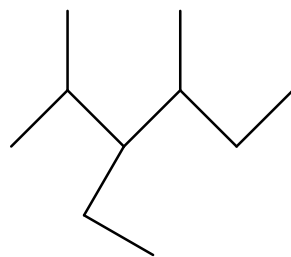

3-ethyl-2,4-dimethylhexane

b) Cycloalkanes

- Cyclic alkanes that contain at least one ring in their structure.
- When naming a cycloalkane in relation to an alkane with the same number of carbon atoms, the prefix **cyclo-** is added.
- If the cycloalkane contains only one substituent, it is not necessary to write the locant.
- A cycloalkane is considered a substituent if the number of carbon atoms in the ring is less than the number of carbon atoms in the chain.

- If there is more than one alkyl group in the structure of cycloalkane, the ring should be enumerated in a way in which all alkyl groups would be at the lowest possible number and, if possible, an alkyl group that is alphabetically first should get a lower number.

EXAMPLE:

a)

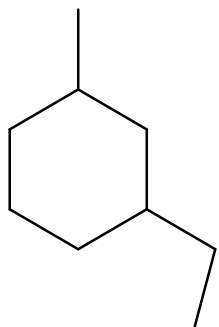

1-ethyl-3-methylcyclohexane

b)

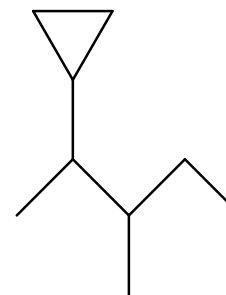

2-cyclopropyl-3-methylpentane

3D structures of molecules can be shown with different models: balls and sticks, spacefill, sticks as **table 2** is showing:

Table 2: Molecular models

compound	balls and stick	spacefill	sticks
etan			
ciklobutan			
buten			
but-2-in			
kloretan			

c) Newman Projection Formulas

Newman projections are used for better visualization of different conformations of molecules. In a Newman projection, we look lengthwise down a specific bond of interest. For example, in the case of the ethane molecule, the bond that we are looking at is the carbon-carbon bond. The 'front' atom is depicted as a dot, and the 'back' atom as a larger circle.

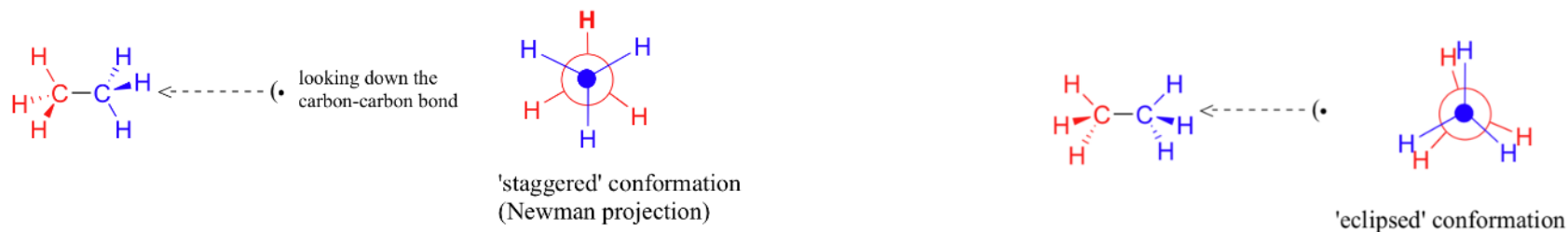

Figure 1 Newman projection formulas (staggered and eclipsed conformation)

If we are looking down the C-C bond in this way, the angle formed between a C-H bond on the front carbon and a C-H bond on the back carbon is called dihedral angle. The lowest energy conformation of ethane, shown in **Figure 1** above, is called the staggered or antiperiplanar conformation. In this type of conformation, all of the dihedral angles are 60° and the distance between the front and back C-H bonds is maximized. After rotating the front $-\text{CH}_3$ group for 60° clockwise, the molecule comes in the highest energy eclipsed or syn-periplanar conformation. In that conformation, the dihedral angles are all 0° (it is necessary to stagger the bonds slightly in this Newman projection so that all of them are still visible). **Figure 2** is showing relative energies of different Newman conformations.

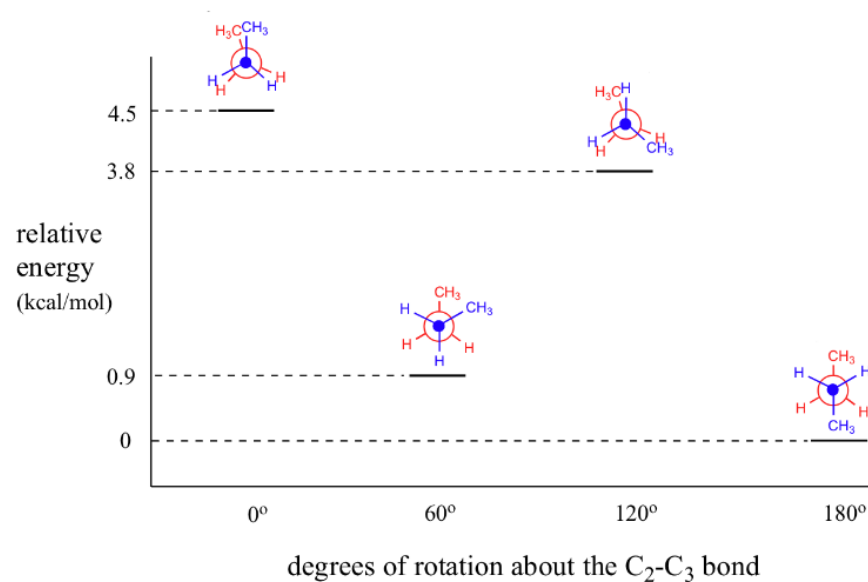

Figure 2 The relative energies for the various Newman conformations

1.2. Educational Outcomes

- to draw different examples of alkane and cycloalkane molecules and present them with a structural, condensed structural formula and with skeletal formula,
- to generate name of previously drawn alkane and cycloalkane molecules in the *ChemSketch* program,
- to determine the molecular formula of previously drawn alkane and cycloalkane molecules in the *ChemSketch* program,
- to improve the presentation of the structure of molecules (adjustment of bond length and interbond angles) using the *Clean Structure* option,
- to draw structural isomers of alkanes and cycloalkanes,
- to show the structures of alkanes and cycloalkanes in three dimensions,
- to rotate alkane and cycloalkane molecules in two and three dimensions,
- to change the way of displaying the structures of alkane and cycloalkane molecules in three dimensions,
- to move alkane and cycloalkane molecules in 3D and 2D,
- to determine bond lengths and bond angles in alkane and cycloalkane molecules,
- to optimize the structures of alkane and cycloalkane molecules,

- to cyclize the straight-chain structure of the alkane molecule into the structure of the corresponding cycloalkane,
- to rotate the molecular structure in three dimensions in order to visually represent the Newman projection formulas of different alkanes,
- to save on the computer the two-dimensional and three-dimensional structure of the desired alkane or cycloalkane molecule.

1.3. Instructions for Using the *ChemSketch* Program

Example 1

Draw the 5-ethyl-2,2-dimethylheptane molecule, then edit the structure according to the instructions, generate its name in the program and determine the molecular formula of that molecule, display it with skeletal formula, structural and condensed structural formula, display the structure of the molecule in three dimensions in different ways, determine the lengths of the selected bonds and specific bond angles, optimize the molecule, rotate and move it in two and three dimensions, save the 2D and 3D structure to the computer, cyclize the structure into the appropriate cycloalkane and generate a name for that molecule, determine the molecular formula, transfer to three dimensions, save both the 2D and 3D structures of the molecule.

STEP 1

Select the *DrawNormal* drawing option. Click on an empty area in the interface. The structure of the methane molecule (CH_4) will appear. Clicking on that carbon atom creates a carbon-carbon single bond. By holding down the *CTRL* key and clicking on each subsequent carbon atom, it is possible to draw the hydrocarbon chain of seven carbon atoms shown in **Figure 1**.

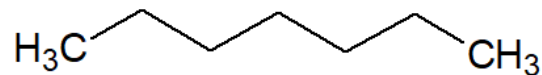

Figure 1. The structure of a hydrocarbon chain of seven carbon atoms

STEP 2

Double-clicking on the second carbon atom creates two methyl groups. One click on the fifth carbon atom creates one methyl group, which can be extended into an ethyl group by clicking on the carbon atom from the methyl group. **Figure 2** shows the structure of the 5-ethyl-2,2-dimethylheptane molecule.

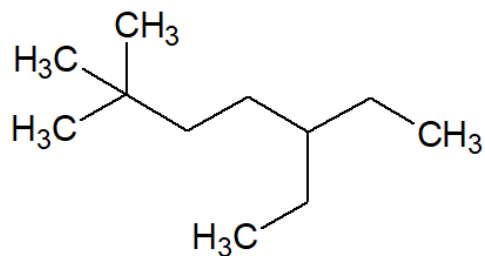
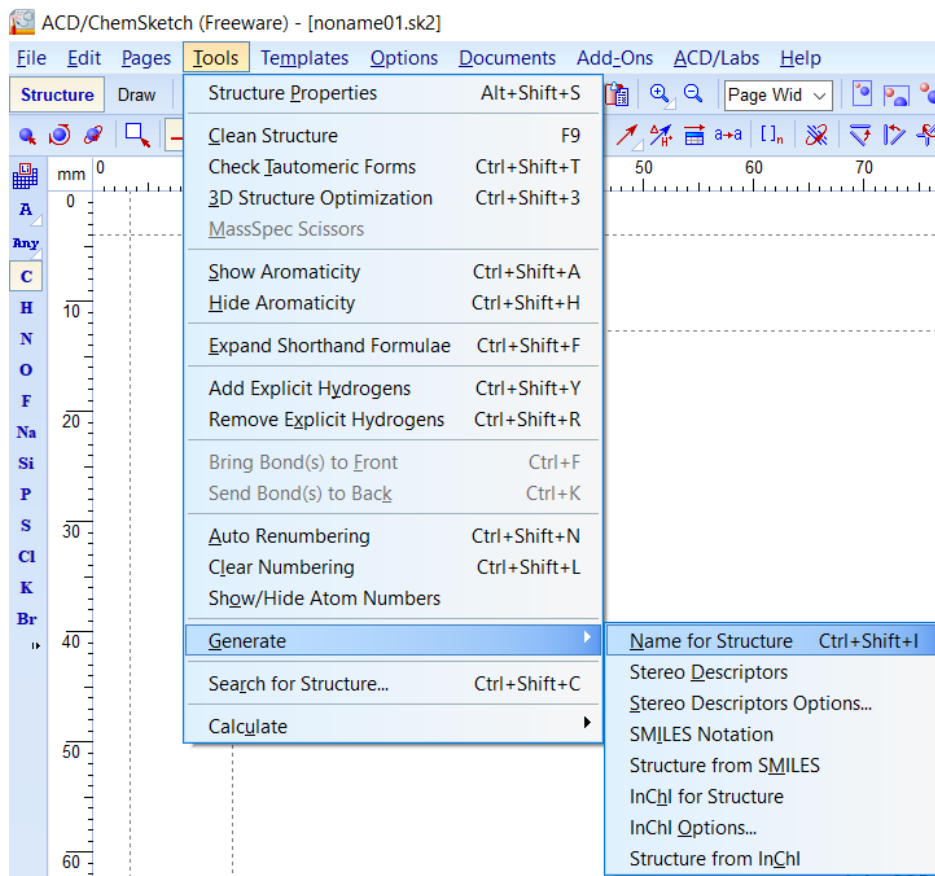

Figure 2. Structure of the 5-ethyl-2,2-dimethylheptane molecule

STEP 3

Click on the *Tools* menu, select the *Generate* option and then click on *Name for Structure*. The mentioned procedure is shown in **Figure 3a**, and in **Figure 3b** the structure of the 5-ethyl-2,2-dimethylheptane molecule is shown, the name is written below. If you didn't get the corresponding name of a molecule, repeat the procedure in **STEP 1** and **STEP 2**.



a

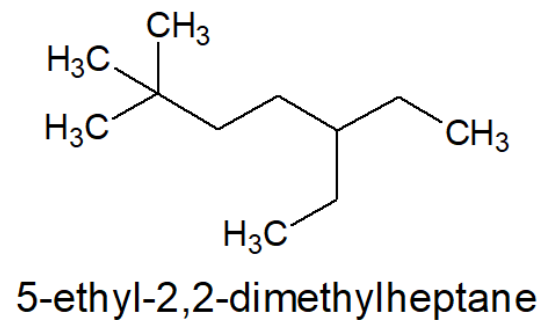

b

Figure 3. a) The procedure for generating the name of a molecule drawn in the *ChemSketch* program, b) the structure and corresponding name of the previously drawn molecule 5-ethyl-2,2-dimethylheptane.

STEP 4

Click on the *Tools* menu, select the *Calculate* option and then click on *Molecular Formula*. The mentioned procedure is shown in **Figure 4a**, and **Figure 4b** shows the molecular formula of 5-ethyl-2,2-dimethylheptane, which is displayed in a new window after performing the sequence of the described options. To display the molecular formula on the worksheet, which contains the structure and name of the drawn molecule, click on *Copy to Editor*.

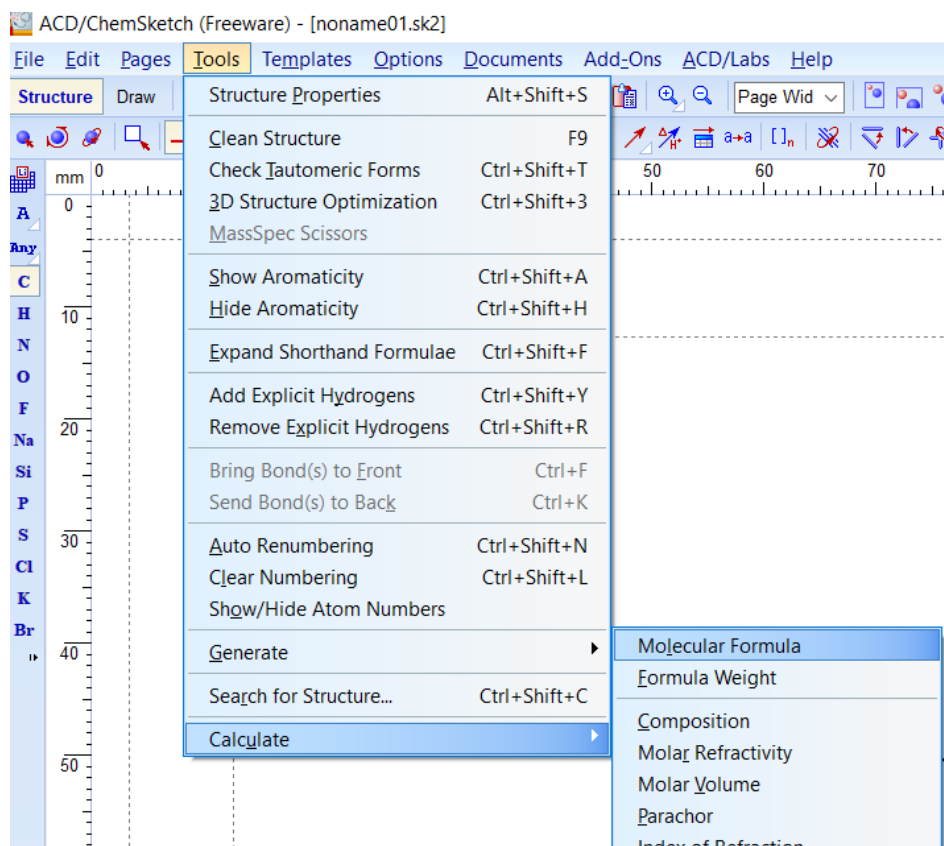

a

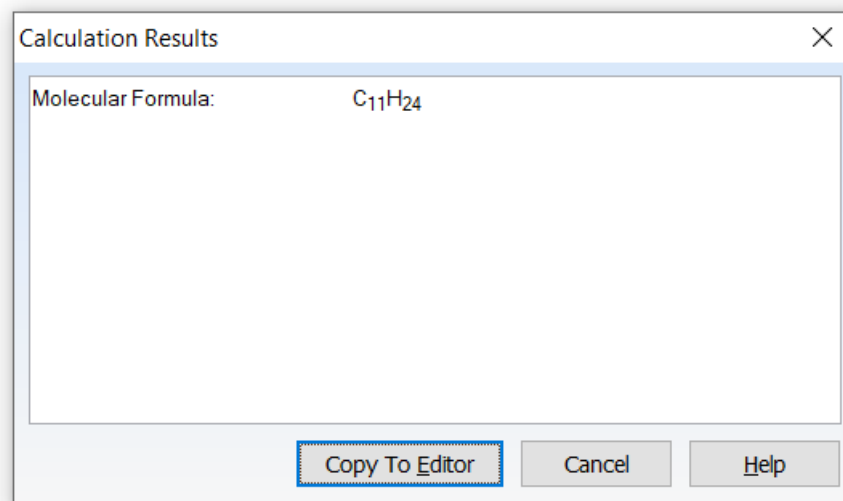

b

Figure 4. a) Sequence of actions for displaying the molecular formula of 5-ethyl-2,2-dimethylheptane, b) Window with the molecular formula of the 5-ethyl-2,2-dimethylheptane molecule.

STEP 5 Using the *Tools* option and clicking on *Clean Structure*, adjust the bond lengths and bond angles (**Figure 5**).

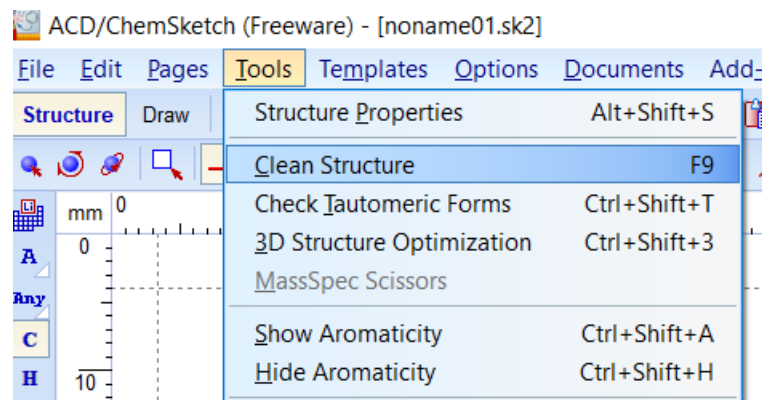





Figure 5. Adjusting bond lengths and bond angles in the *ChemSketch* program

STEP 6A Show the structure of the 5-ethyl-2,2-dimethylheptane molecule with skeletal formula, a condensed structural formula, and a structural formula.

To do this successfully, it is necessary to select the entire structure of the molecule by clicking on  in the upper left corner of the interface, and then adjusting the way of selecting the molecule by clicking on , the following icon appears: . While holding the click, drag and select the entire molecule.

STEP 6B By clicking on the *Tools* option, and then on *Structure Properties*, a window opens with all the desired options. **Figure 6a** shows the procedure for opening the window, and **Figure 6b** shows the options you need to adjust (in the *Show Carbons* section, click on *All* and then *Apply*). **Figure 6c** shows the resulting structure of the 5-ethyl-2,2-dimethylheptane molecule represented by skeletal formula.

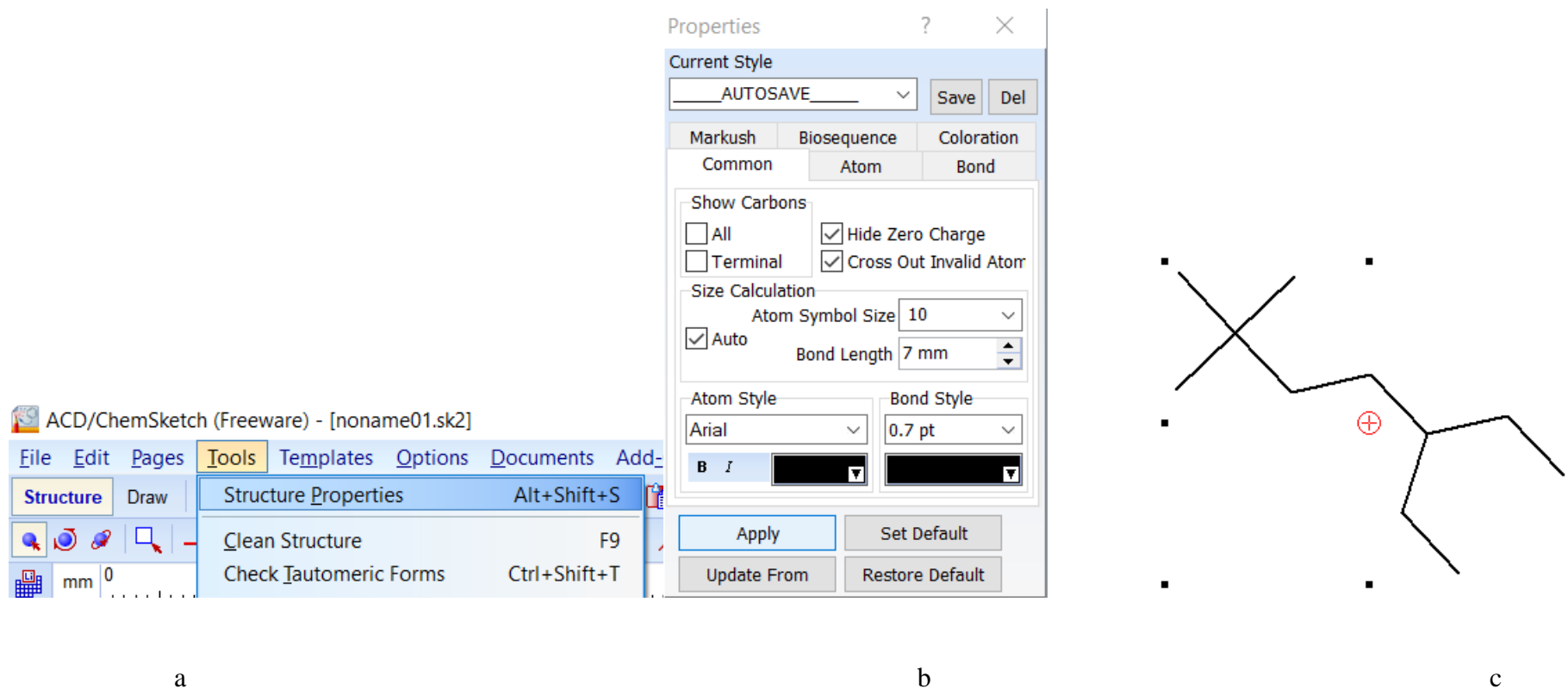
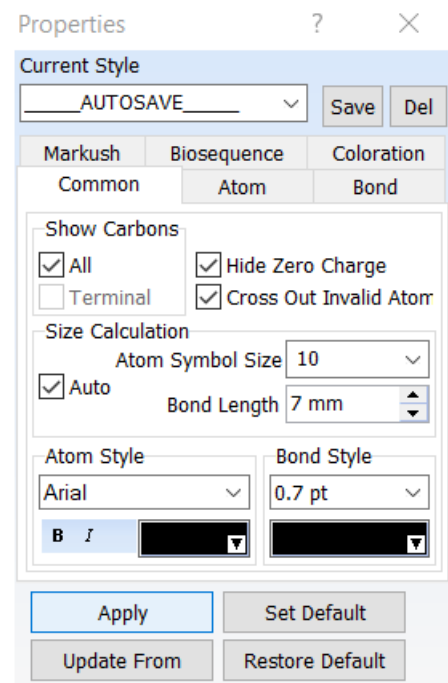
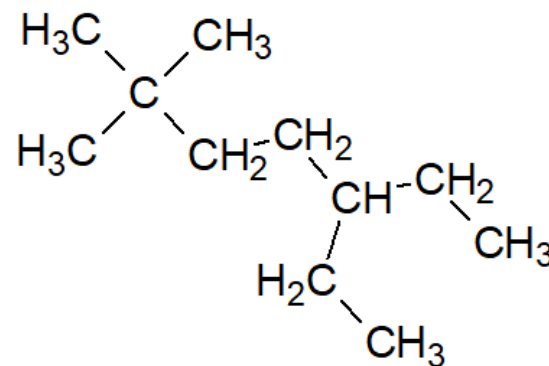

Figure 6. a) The procedure for opening the window for adjusting the way the molecular structure is displayed, b) the window with all options for displaying the molecular structure with selected options for displaying the molecular structure with skeletal formula, c) the structure of the 5-ethyl-2,2-dimethylheptane molecule shown with skeletal formula.

STEP 6C Select the molecule again, click on *Tools*, then on *Structure Properties* and adjust the parameters according to **Figure 7**.



a



b

Figure 7. a) Window with adjusted parameters for displaying the structure of the molecule with a condensed structural formula, b) Structure of the 5-ethyl-2,2-dimethylheptane molecule shown with a condensed structural formula.

STEP 6D To display the structure of the 5-ethyl-2,2-dimethylheptane molecule with the structural formula, click on *Tools* and then on the *Add Explicit Hydrogens* option. After that, use the *Clean Structure* option to edit the displayed structure (**Figure 8a** shows the procedure for showing all carbon-hydrogen bonds and **Figure 8b** shows the structural formula of the 5-ethyl-2,2-dimethylheptane molecule).

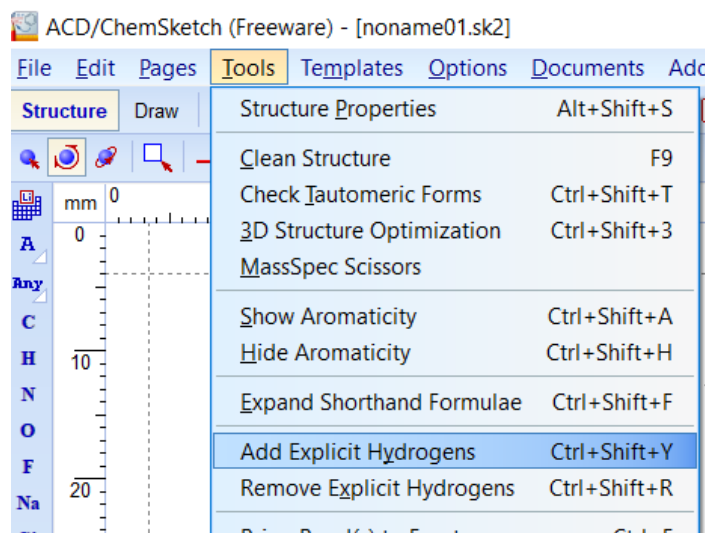

a

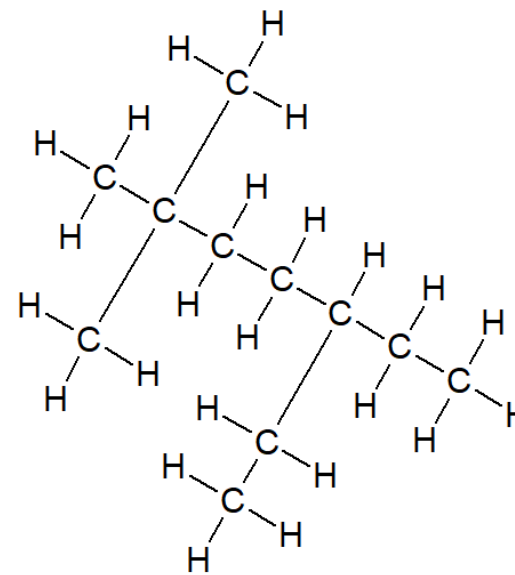

b

Figure 8. a) Instructions for displaying all carbon-hydrogen bonds, b) Structural formula of the 5-ethyl-2,2-dimethylheptane molecule.

STEP 7 Display the resulting structural formula of 5-ethyl-2,2-dimethylheptane in three dimensions by first selecting it and then clicking on the option  on the toolbar. A new window (*3D Viewer*) will open with a 3D view of the molecule (**Figure 9**). By positioning the mouse icon on each individual atom, its numerical designation according to the IUPAC nomenclature and its coordinates appear.

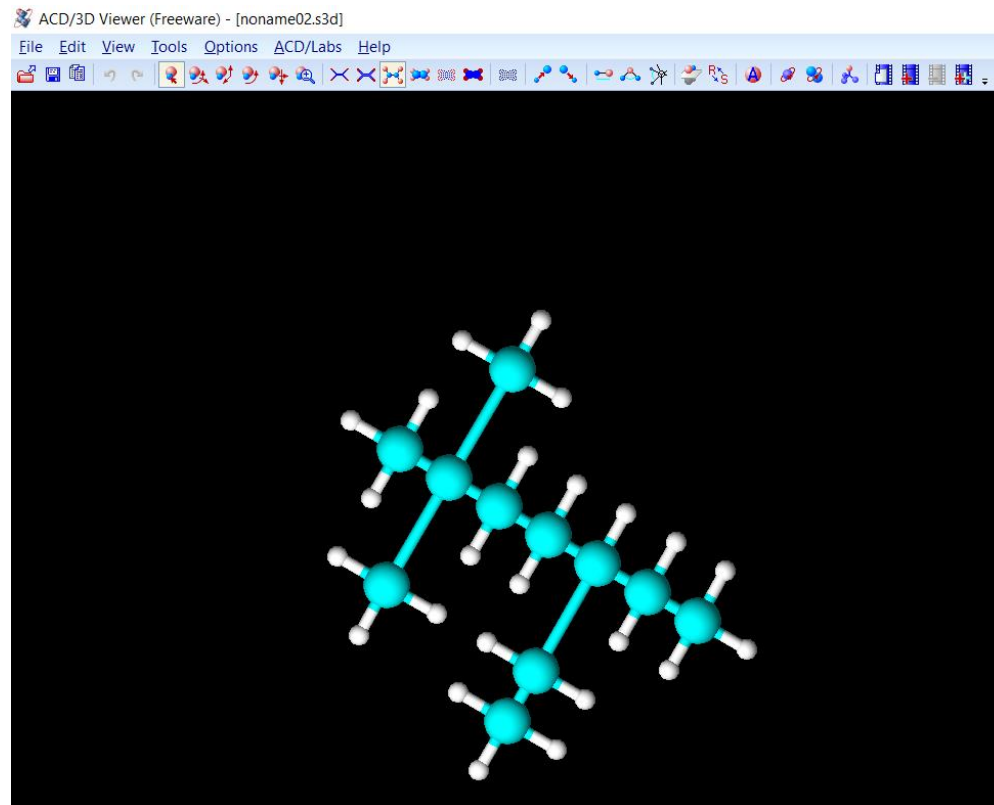







Figure 9. 3D structure of the 5-ethyl-2,2-dimethylheptane molecule.

STEP 8

- Try using each of the rotate, move, and select options on the top toolbar: , and then display the molecule in each of the ways the program offers, and the options are also displayed on the toolbar: .
- Clicking on any of the options changes the way the 5-ethyl-2,2-dimethylheptane molecule is displayed. For automatic rotation of the molecule, click on the icon .

- For automatic continuous change from one to another molecule display mode with rotation, click on the icon .

STEP 9 Determine the bond length between the first and the second carbon atom by clicking on the icon  and by clicking on the first and the second carbon atom. A new window will appear in which the length of the selected bond will be written (**Figure 10**).

What bond length do you expect? _____.

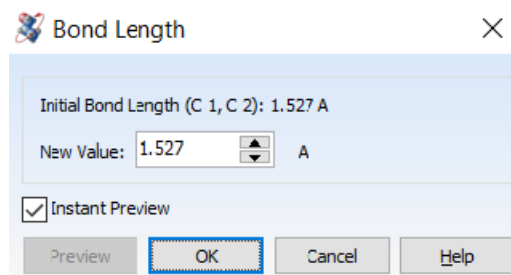



Figure 10. Determination of the bond length between the first and the second carbon atom in the 5-ethyl-2,2-dimethylheptane molecule.

STEP 10 By clicking on the icon for 3D optimization () , it is possible to represent the molecular structure with much more "realistic" bond lengths and bond angles. The structure edited in this way can be returned from three dimensions to two dimensions of the *ChemSketch* program by clicking on the *Copy to ChemSketch* option and selecting the *Structure* option (**Figure 11**) at the very bottom of the interface. The optimized structure of the 5-ethyl-2,2-dimethylheptane molecule now appears in *ChemSketch*.

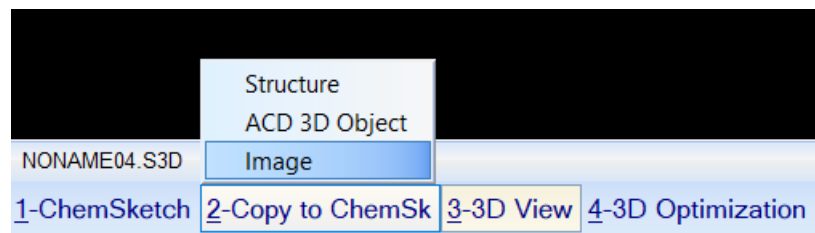

Figure 11. Moving the optimized 3D structure to *ChemSketch*.

STEP 11 Save both the 2D and 3D structures of the 5-ethyl-2,2-dimethylheptane molecule to your desktop by clicking *File*, then *Save As* in the 3D structure window, typing a name for the structure, selecting the *Save to Desktop* option, and clicking *Save*. Repeat the same procedure for the 2D structure in *ChemSketch* (Figure 12).

File	Edit	View	Tools
Open...			F3
Close			Ctrl+F4
Save			F2
Save As...			Shift+F2
Print			Ctrl+P
Printer Setup...			
Send...			
File Associations...			
Exit			Alt+X

Figure 12. Saving a 2D or 3D structure on a computer

TASK 2 Draw 1-ethyl-4,4-dimethylcyclohexane by using the option *DrawNormal*. Use option *Clean Structure* (*Tools* ▢ *Clean Structure*) to adjust bond lengths and bond angles and then do the following actions:

- generate the name of a molecule and check if the drawn structure is correct,
- determine molecular formula of a drawn molecule _____,
- transfer that structure to 3D Viewer,
- save both 2D and 3D structures to your computer.

Example 2 Draw ethane molecule and then display it in 3 dimensions by using the tool *3D Viewer*. Try to rotate the whole molecule until you get the position showing antiperiplanar conformation of ethane. Look lengthwise down a carbon-carbon bond.

1.4. Examples of Tasks for Processing Teaching Content

1. Draw all the structural isomers of butane. Write the names of all the isomers, then choose one and do the following with it:

- a) generate the name,
- b) determine the molecular formula,
- c) show the structure with a condensed structural formula, skeletal and structural formula,
- d) edit the structure of the molecule with the *Clean Structure* option,
- e) display the structure of the molecule in the *3D Viewer*,
- f) display the structure of the molecule in the *3D Viewer* using sticks and balls,
- g) optimize the molecule,
- h) determine the length of the bond between the first and second carbon atoms,
- i) determine the bond angle in the ring - between the first and second carbon atom,
- j) save both the 2D and 3D structure of the molecule on the desktop of a computer.

2. Explore the applications of alkanes and cycloalkanes in everyday life. Select one molecule to display in the *ChemSketch* program. Write in your notebook the application of the chosen molecule in everyday life. Save the optimized 2D and 3D structures of these molecules to your computer.

3. Draw the structure of 1,1,3-trimethylcyclopentane and then do the following:

- a) generate the name,
- b) determine the molecular formula,
- c) show the structure with a condensed structural formula, skeletal and structural formula,
- d) edit the structure of the molecule with the *Clean Structure* option,
- e) display the structure of the molecule in the *3D Viewer*,
- f) display the structure of the molecule in the *3D Viewer* using sticks and balls,
- g) optimize the molecule,

- h) determine the length of the bond between the first and the second carbon atom,
- i) determine the bond angle in the ring - between the first and the second carbon atom,
- j) save both the 2D and 3D structures of the molecule on the desktop of a computer.

4. Draw a propane molecule and then display it in 3 dimensions by using the tool *3D Viewer*. Try to rotate the whole molecule until you get the position showing antiperiplanar conformation of propane. Look lengthwise down a covalent bond between the first and the second carbon atom.

1.5. Examples of Students Evaluation Tasks

1. Draw all structural isomers of pentane. Write the names of all the isomers, then choose one and do the following with it:

- a) generate the name,
- b) determine the molecular formula,
- c) show the structure with a condensed structural formula, skeletal formula and structural formula,
- d) edit the structure of the molecule with the *Clean Structure* option,
- e) display the structure of the molecule in the *3D Viewer*,
- f) display the structure of the molecule in the *3D Viewer* using sticks and balls,
- g) optimize the molecule,
- h) determine the length of the bond between the first and the second carbon atom,
- i) determine the bond angle in the ring - between the first and the second carbon atom,
- j) save both the 2D and 3D structure of the molecule on the desktop computer.

2. Draw a butane molecule and then display it in 3 dimensions by using the tool *3D Viewer*. Try to rotate the whole molecule until you get the position showing antiperiplanar conformation of butane. Look lengthwise down a covalent bond between the first and second carbon atom.

ALKENES AND ALKYNES

1.) ELABORATION OF THE UNIT TITLE

Teaching unit: Unsaturated Hydrocarbons
Unit title: Alkenes and Alkynes
Estimated number of hours:2

1.1. Theoretical introduction

a) Alkenes

Alkenes are unsaturated hydrocarbons that contain at least one double covalent bond between carbon atoms in their structure. Alkenes contain fewer hydrogen atoms than alkanes and are therefore unsaturated hydrocarbons. The general formula of alkene is: C_nH_{2n} . In the general formula of alkene, n - represents the number of carbon atoms. The simplest representative of alkene is ethene, C_2H_4 . The homologous series of alkenes continues with propene of the molecular formula C_3H_6 , then but-1-ene (C_4H_8), etc. Alkenes appear as structural isomers and as stereoisomers starting with but-1-ene. Cycloalkenes are ring alkenes of the general formula: C_nH_{2n-2} . Alkenes with a simpler structure are generally named like alkanes, according to the IUPAC hydrocarbon naming rules. The name of alkene is obtained by adding the suffix *-en* to the root, which indicates the number of carbon atoms in the molecule. The sequence number after the root of the alkene name indicates the position of the double bond. In alkene molecules, two or more double bonds can occur between carbon atoms. Alkenes with two double bonds are called dienes, and when naming such compounds, instead of the suffix *-en*, we add the suffix *-dien*. Double bonds in alkenes can appear as isolated (**Figure 1a**), conjugated (**Figure 1b**) and cumulated (**Figure 1c**).

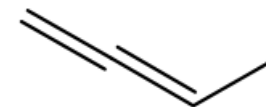
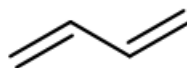

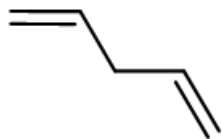

Figure 1. a) isolated double bond

b) conjugated double bond

c) cumulated double bond

b) Alkynes

Alkynes are unsaturated hydrocarbons and contain at least one triple bond. The general formula of alkynes is C_nH_{2n-2} .

Alkynes occur in nature in very small numbers. Natural alkynes are strong poisons or have fungicidal, antibacterial or anticancer effects.

1.2. Educational Outcomes

In this chapter, students will learn:

- to connect the term unsaturation with the presence of a double bond between carbon atoms,
- to draw different examples of alkene and alkyne molecules and present them with a structural, condensed structural formula and with skeletal formula,
- to generate name of previously drawn alkene and alkyne molecules in the *ChemSketch* program,
- to determine the molecular formula of previously drawn alkene and alkyne molecules in the *ChemSketch* program,
- to improve the representation of the structure of molecules (adjustment of bond length and interbond angles) using the *Clean Structure* option,
- to draw structural isomers of alkene and alkyne,
- to show the structures of alkene and alkyne in three dimensions,
- to rotate alkene and alkyne molecules in two and three dimensions,

- to change the way of displaying the structures of alkene and alkyne molecules in three dimensions,
- to move alkene and alkyne molecules in 3D and 2D,
- to determine bond lengths and bond angles in alkene and alkyne molecules,
- to optimize the structures of alkene and alkyne molecules,
- to save on the computer the two-dimensional and three-dimensional structure of the desired alkene and alkyne molecule,
- to draw structural formulas of cycloalkenes.

1.3. Instructions for Using the *ChemSketch* Program

Example 1

Draw the ethene molecule, then edit the structure according to the instructions; generate its name in the program and determine the molecular formula of the molecule, display it with skeletal formula, structural and condensed structural formula, display the structure of the molecule in three dimensions in different ways, determine the lengths of the selected bonds and specific bond angles, optimize the molecule, rotate and move it in two and three dimensions, save the 2D and 3D structure to the computer. Draw a cycloalkene and generate a name for that molecule, determine the molecular formula, transfer to three dimensions, save both the 2D and 3D structure of the molecule. Then draw the but-2-in molecule and repeat all the steps as instructed.

STEP 1

Select the *DrawNormal* drawing option. Click on an empty area in the interface. The structure of the methane molecule (CH₄) will appear. By clicking on that carbon atom, a carbon-carbon single bond will be created. Draw ethane structure and then point to the single bond between the first two carbon atoms from the hydrocarbon chain (you will see a rectangle around the bond shown in **Figure 1a**), and then click it to make a double bond (**Figure 1b and c**).

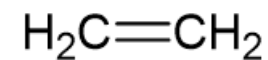
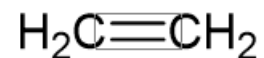

Figure 1. a) rectangle around the bond

b) double bond in ethene

c) double bond in ethene

STEP 2

Naming the structure of alkene: Click on the *Tools* menu, select the *Generate* option and then click on *Name for Structure*. The mentioned procedure is shown in **Figure 2a**, and in **Figure 2b** the structure of the ethene molecule is shown, and its name is written below.

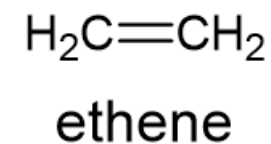
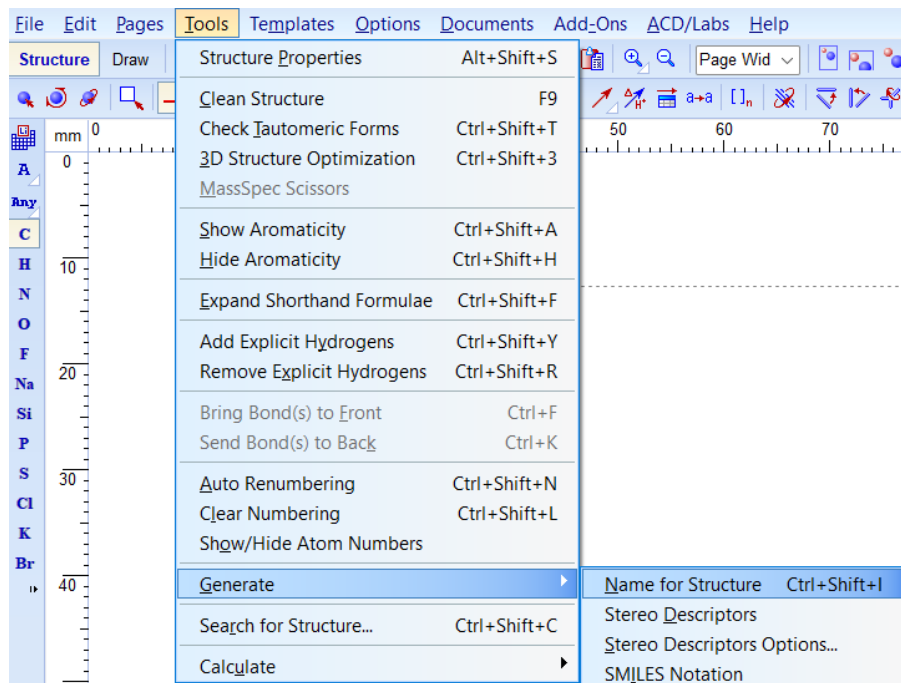

b)

a)

Figure 2. a) The procedure for generating the name of a molecule drawn in the *ChemSketch* program, b) the structure and corresponding name of the previously drawn molecule ethene.

STEP 3

Using the *Tools menu*, select the *Calculate* option and then click on *Molecular Formula* (**Figure 3a**). After that, a window will open showing the molecular formula (**Figure 3b**). To display the molecular formula with the alkene structure on the worksheet, click on *Copy To Editor* (**Figure 3c**).

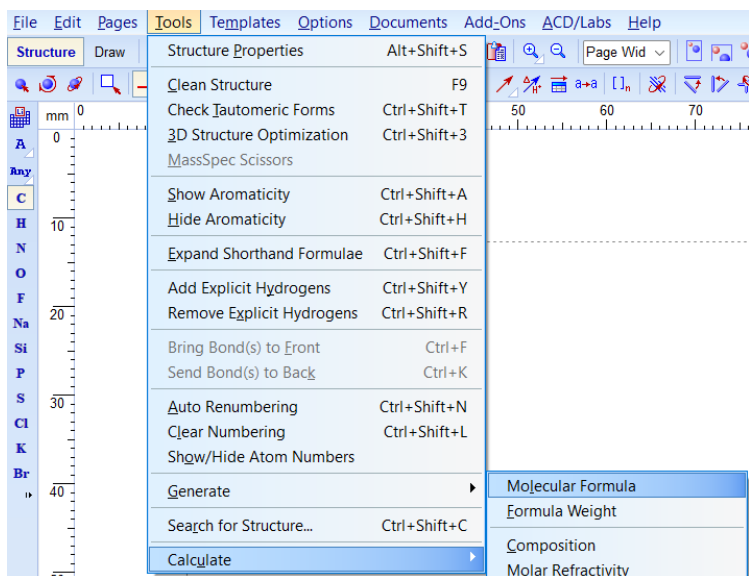

a)

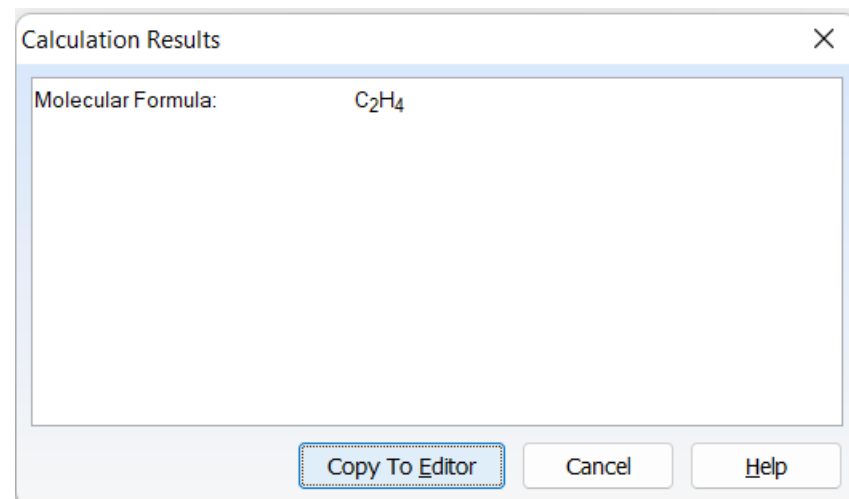

b)

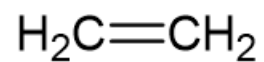

ethene

Molecular Formula: C_2H_4

c)

Figure 3 a) Sequence of actions for displaying the molecular formula of ethene, b) Window with the molecular formula of the ethene molecule, c) Molecular formula on the worksheet.



STEP 4

Using the *Tools* option and clicking on *Clean Structure*, adjust the bond lengths and bond angles. (**Figure 4**)

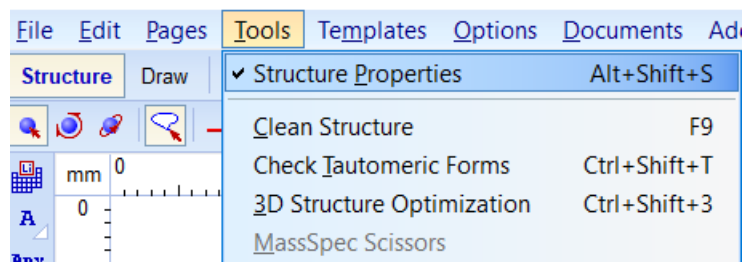

Figure 4. Adjusting bond lengths and bond angles in the *ChemSketch* program

STEP 5

Show the structure of the ethene molecule with skeletal formula. To do this successfully, it is necessary to select the entire structure of the molecule by clicking on  in the upper left corner of the interface, and then adjust the way of selecting the molecule by clicking on , the following icon appears: . While holding the click, drag and select the entire molecule.

By clicking on the *Tools* option, and then on *Structure Properties*, a window opens with all the desired options. **Figure 5a** shows the procedure for opening the window, and **Figure 5b** shows the options you need to adjust (in the *Show Carbons* section, unclick on *Terminal* and then *Apply*). **Figure 5c** shows the resulting structure of the ethene molecule represented by skeletal formula.



a)

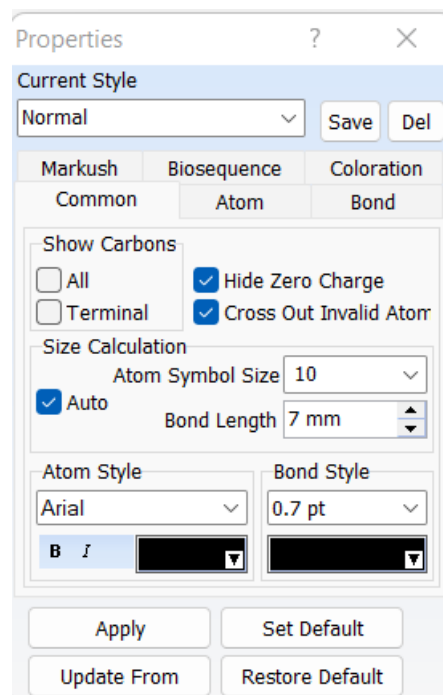

b)

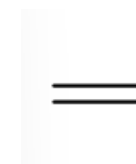

c)

Figure 5. a) The procedure for opening the window for adjusting the way the molecular structure is displayed, b) the window with all options for displaying the molecular structure with selected options for displaying the molecular structure with skeletal formula, c) the structure of the ethene molecule shown with skeletal formula.

STEP 6

Using the *Tools* option, select the *Add Explicit Hydrogens* option to display hydrogen atoms on skeletal formula of ethene (**Figure 6a**). You can also show it on the structural formula of ethene as shown in **Figure 6b**.

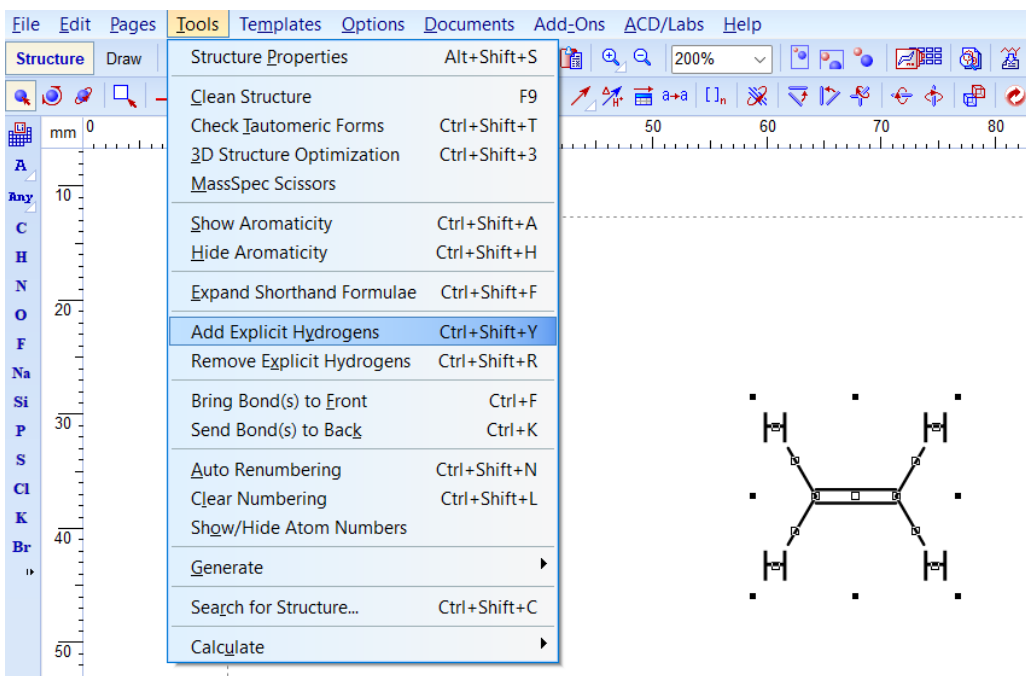

b)

a)

Figure 6. a) Instructions for displaying all carbon-hydrogen bonds, b) Structural formula of the ethene molecule.

STEP 7

Display the resulting structural formula of ethene in three dimensions by first selecting it and then clicking on the option  on the toolbar. A new window

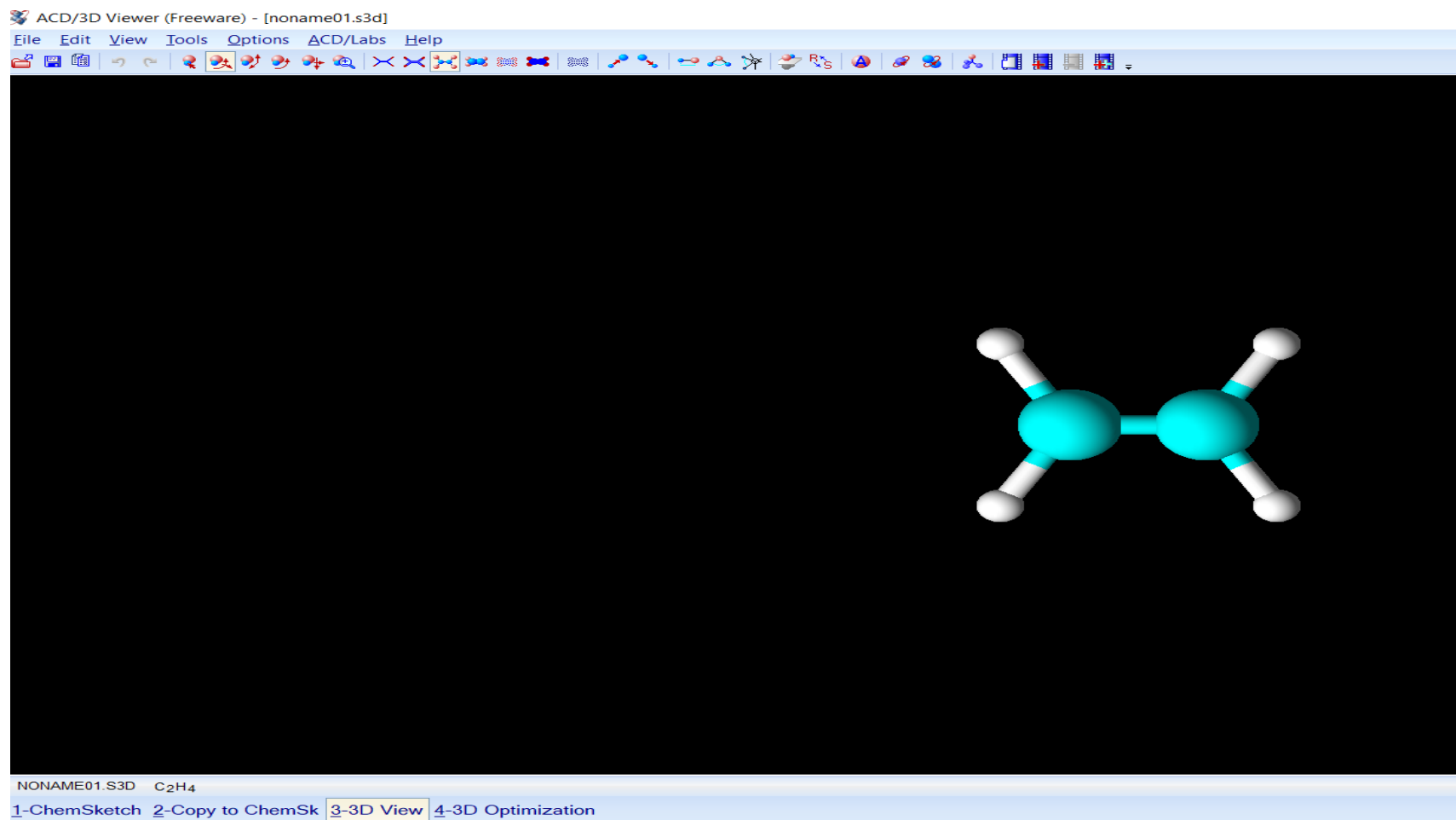



(3D Viewer) will open with a 3D view of the molecule (**Figure 7**). By positioning the mouse icon on each individual atom, its numerical designation according to the IUPAC nomenclature and its coordinates appear.

Figure 7. 3D structure of the ethene molecule.

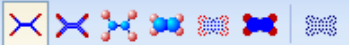
STEP 8

Try using each of the rotate, move, and select options on the top toolbar: , and then display the molecule in each of the ways the program offers, the options are also displayed on the toolbar: .

Clicking on any of the options changes the way the ethene molecule is displayed. For automatic rotation of the molecule, click on the icon .

For automatic continuous change from one to another molecule display mode with rotation, click on the icon .

STEP 9

To calculate or change the distance between two atoms, perform the following steps:

Switch to the *Balls and Sticks* view mode (on the Top toolbar, click *Balls and Sticks* ) for a better view of the atoms.

On the Top toolbar, click *Bond Length* () (**Figure 8**).

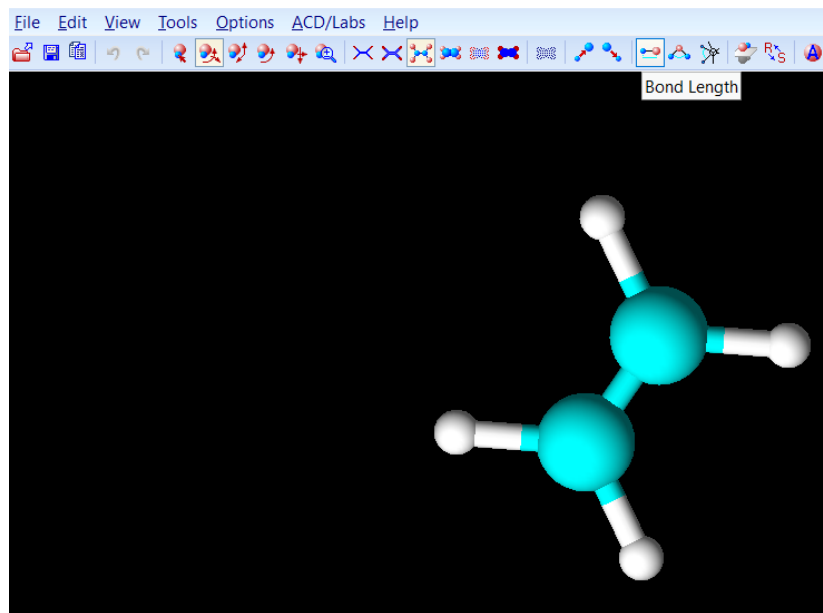

When you have selected the *Bond Length* option, in *3D view*, select the two atoms between which you want to determine the bond length. A new window will open with the calculated bond length value (**Figure 9**).

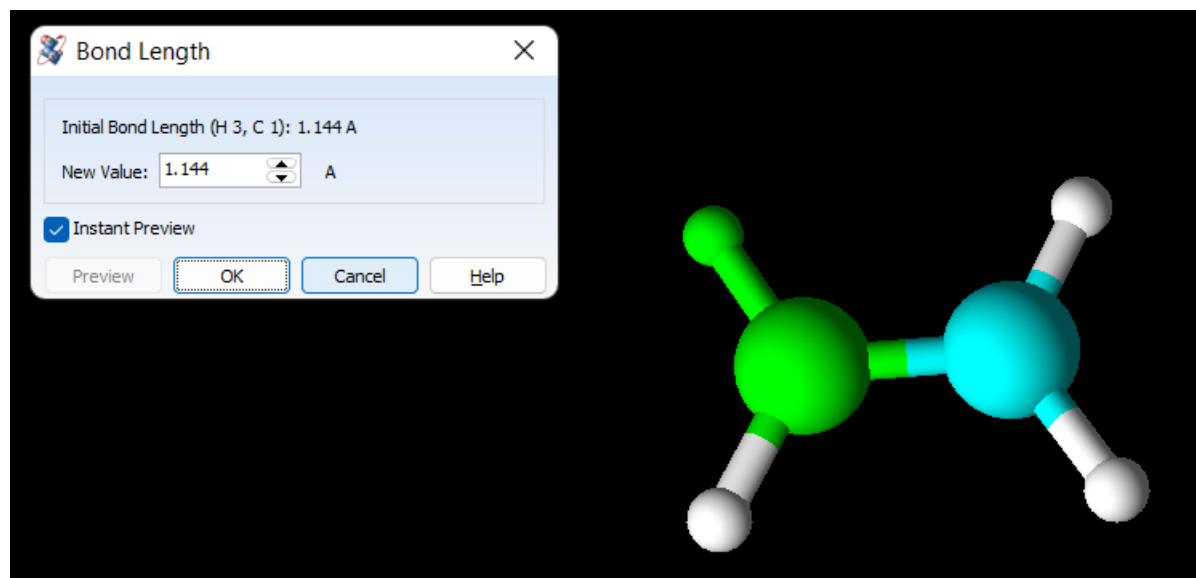

Figure 9. Determination of the bond length between the first carbon atom and hydrogen in the ethene molecule.

STEP 10

To determine the bond angle, select the *Bond Angle* option on the toolbar (**Figure 10**). Then, in order to determine the bond angle between two carbon atoms, we must first click on the hydrogen atom and then on both carbon atoms. A new window with the displayed value will open (**Figure 11**).

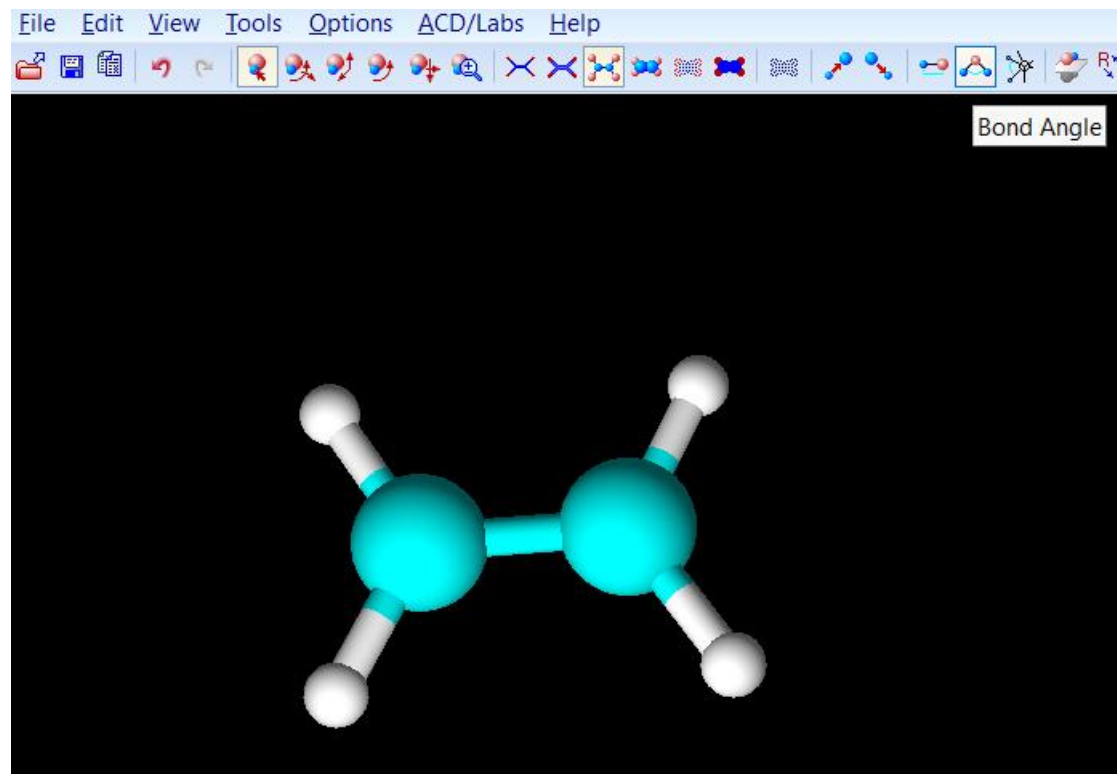

Figure 10. Option *Bond Angle* on the toolbar

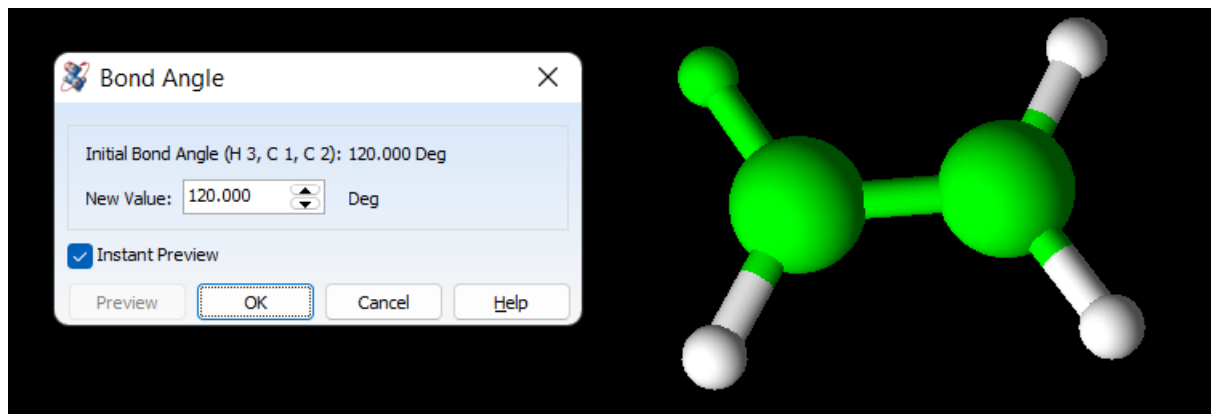

Figure 11. Determine the bond angle between the first and second carbon atoms and the 3rd hydrogen atom

STEP 11

By clicking on the icon for 3D optimization (🔍), it is possible to show the molecular structure with much more "realistic" bond lengths and bond angles. The structure edited in this way can be returned from three dimensions to two dimensions of the *ChemSketch* program by clicking on the *Copy to ChemSketch* option and selecting the *Structure* option (**Figure 12**) at the very bottom of the interface. The optimized structure of the ethene molecule now appears in *ChemSketch*.

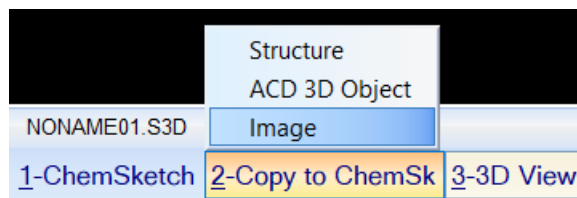

Figure 12. Moving the optimized 3D structure to *ChemSketch*.

STEP 12

Save both the 2D and 3D structures of the ethene molecule to your desktop by clicking *File*, then *Save As* in the 3D structure window, typing a name for the structure, selecting the *Save to desktop* option, and clicking *Save*. Repeat the same procedure for the 2D structure in *ChemSketch* (**Figure 13**).

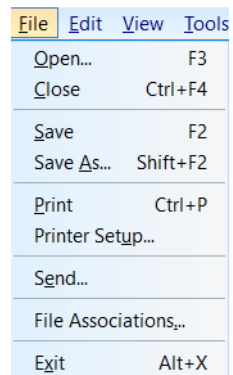
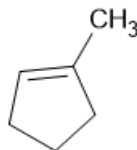

Figure 13. Saving a 2D or 3D structure on a computer

STEP 13

Draw the 1-methylcyclopent-1-ene molecule following the steps previously learned (**Figure 14**). Then apply previously learned steps from 2 to 12 in this example.



1-methylcyclopent-1-ene

Figure 14. Structural representation of the 1-methylcyclopent-1-ene molecule

STEP 14a

Draw the but-2-in molecule: Select the *DrawNormal* drawing option. Click on an empty area in the interface. The structure of the methane molecule (CH₄) will appear. Clicking on that carbon atom creates a carbon-carbon single bond. By holding down the *Ctrl* key and clicking on each subsequent carbon atom, it is possible to draw the hydrocarbon chain of four carbon atoms shown in **Figure 15**.

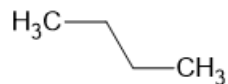
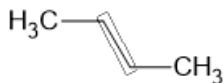

Figure 15. Butane molecule

STEP 14b

On the previously drawn structure, point the pointer between the second and third carbon atoms on the single bond and click twice to make a triple bond (you will see a rectangle around the bond shown in **Figure 16a**, and then click it to make a triple bond (**Figure 16b**). Apply the previously learned steps from steps 2 to 12.



a)

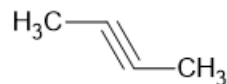

b)

Figure 16. a) rectangle around the bond, b) But-2-in molecule

1.4. Examples of Tasks for Processing Teaching Content

* Research what a molecule of natural rubber looks like and display the molecule in the *ChemSketch* program. When you have drawn a molecule of natural rubber, explore how the molecule looks in 3D form and apply the learned functions in *ChemSketch*.

1. Draw the 4-methylpent-2-ene molecule and do the following with it:

- a) generate the name,
- b) determine the molecular formula,
- c) show the structure with a condensed structural formula, skeletal and structural formula,
- d) edit the structure of the molecule with the *Clean Structure* option,
- e) display the structure of the molecule in the *3D Viewer*,
- f) display the structure of the molecule in the *3D Viewer* using sticks and balls,
- g) optimize the molecule,
- h) determine the length of the bond between the first and second carbon atoms,
- i) determine the bond angle in the ring - between the first and second carbon atoms,
- j) save both the 2D and 3D structure of the molecule on the desktop of a computer,
- k) open the 2D structure of the molecule and make a cyclic structure from it and generate its name and molecular formula.

2. Explore the applications of alkenes and alkynes in everyday life. Select one molecule to display in the *ChemSketch* program. Write in your notebook the application of the chosen molecule in everyday life.

Save the optimized 2D and 3D structure of these molecules to your computer.

1.5. Examples of Students Evaluation Tasks

1. Draw the 2-methylpent-1-en-3-yne molecule and do the following:

- a) generate the name,
- b) determine the molecular formula,
- c) show the structure with a condensed structural formula, skeletal and structural formula,
- d) edit the structure of the molecule with the *Clean Structure* option,
- e) display the structure of the molecule in the *3D Viewer*,
- f) display the structure of the molecule in the *3D Viewer* using sticks and balls,
- g) optimize the molecule,
- h) determine the length of the bond between the first and second carbon atoms,
- i) determine the bond angle in the ring - between the first and second carbon atoms,
- j) save both the 2D and 3D structure of the molecule on the desktop of a computer,
- k) open the 2D structure of the molecule, make a cyclic structure from it and generate its name and molecular formula.

ARENES

1) ELABORATION OF SELECTED CHAPTERS

Teaching unit: Arenes
Unit title: Arenes-nomenclature, isomerism, preparation and properties of arenes
Estimated number of hours: 2

4.1. Theoretical introduction to the chapter

Arenes are unsaturated aromatic hydrocarbons, derivatives of benzene with one or more aliphatic radicals. Arenes can be found in nature in hard coal and petroleum derivatives, but they can also be obtained by electrophilic substitution of one or more hydrogen atoms from the benzene nucleus. When one of the positions of the benzene ring is replaced by another atom or atomic group, the compound is monosubstituted benzene. When the substituent is an alkyl, alkenyl or alkynyl radical, then this group of compounds are arenes. They can be monosubstituted, disubstituted, trisubstituted and polysubstituted with the general formula Ar-R or C₆H₅-R whose nomenclature is formed by adding the name of the radical before the word benzene.

When two of the ring positions are replaced by radicals, the compound is a disubstituted benzene. There is a special nomenclature to describe the relative positions. Using toluene as an example, the ortho orientation is the 1,2 position; meta is 1,3; and the value 1,4 is para position where it is noted that there can be two ortho and meta positions each but only one para position.

Example: C₆H₅-CH₃ methylbenzene (toluene) (**Figure 4**) and C₆H₅-CH₂-CH₃ ethylbenzene. (**Figure 5**)

Because the hydrogen atoms in the benzene molecule are equivalent, three isomeric substituted derivatives of benzene are possible: monosubstituted and disubstituted arenes.

Example: 1,2-dimethyl benzene or trivial name o-xylene; 1,3-dimethylbenzene (m-xylene) and 1,4-dimethylbenzene (p-xylene) and C₆H₅-(CH₃)₃ 1,2,3-trimethylbenzene (vicinal isomer); 1,2,4-trimethylbenzene (asymmetric isomer) and 1,2,4- trimethylbenzene (symmetric isomer) (**Figure 7**).

Depending on the type of radical, we can distinguish alkylbenzenes, alkenylbenzenes and alkenylbenzenes.

Arenes are obtained by alkylation reaction Friedel Kraftz synthesis.



4.2. Educational outcomes of the selected chapter

In this chapter, students will learn:

- to draw different examples of arene molecules and present them with a structural, condensed structural formula and with skeletal formula,
- to generate name of previously drawn arene molecules in the *ChemSketch* program,
- to determine the molecular formula of previously drawn arene molecules in the *ChemSketch* program,
- to improve the representation of the structure of molecules (adjustment of bond length and interbond angles) using the *Clean Structure* option,
- to draw structural isomers of arenes,
- to show the structures of arenes in three dimensions,
- to rotate arene molecules in two and three dimensions,
- to change the way of displaying the structures of molecules in three dimensions,
- to move arene molecules in 3D and 2D,
- to determine bond lengths and bond angles,
- to optimize the structures of arene molecules,
- to save the two-dimensional and three-dimensional structure of the desired arenes molecule on the computer.

4.3. Instructions for using the *ChemSketch* software for the selected chapter

Task 1.

To draw benzene molecule as the basis of aromatic arene compounds, the first step is to open the *ChemSketch* program, and then the *Draw Normal* tool (). With this tool, you can easily draw straight or branched hydrocarbon chains. Draw the benzene molecule, but first make sure that the **Draw Normal** tool is enabled on the **Structure** toolbar and that the **Carbon** icon () is selected on the **Atoms** toolbar (**Figure 1a**).

Example 1.

Draw a molecule of benzene, methylbenzene (toluene) and ethylbenzene.

Example 2

- Draw examples of monosubstituted, disubstituted and trisubstituted benzene derivatives, generate their names, determine the molecular formulas of these molecules, and depict them using the skeletal formula, structural and condensed structural formula.
- Display the structure of molecules in three dimensions in different ways, determine selected bond lengths and bond angles, optimize molecules, rotate and move them in two and three dimensions.
- Save 2D and 3D structure of molecules.

Example 1

Draw a benzene molecule using the alkane to cycloalkane cyclization tools from the corresponding structure of the *ChemSketch* program, and then the *Draw*

Normal tool ()

STEP 1 Draw the benzene molecule by clicking on the *Draw Normal* tool in the *Structure* toolbar and selecting the *Carbon* button  from the *Atoms* toolbar.

STEP 2 To start drawing the formula, click on an empty space and the molecular formula of methane CH₄ will appear (**Figure 1**).

STEP 3 Highlight the CH₄ formula and when you see a rectangle around the methane formula, click on it to add a methyl group making ethane H₃C-CH₃.

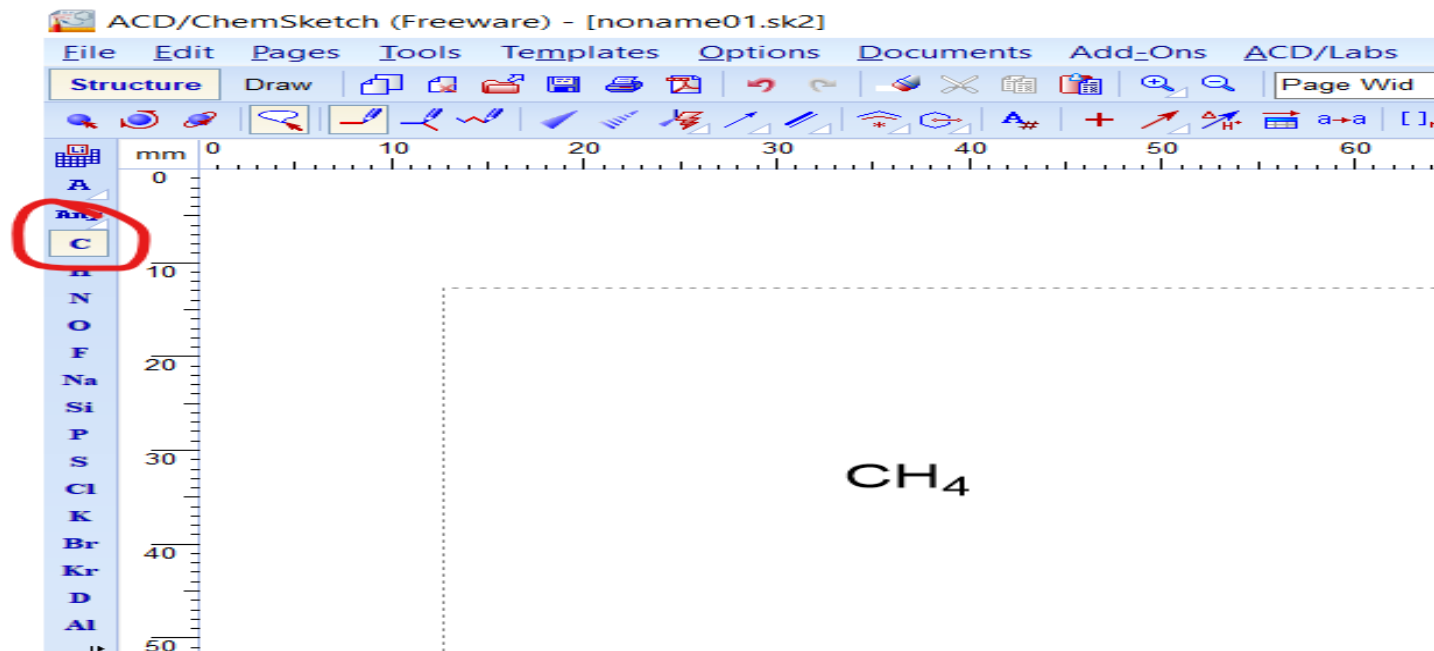

Figure 1. Condensed structural formula of the methane molecule

STEP 4





Click on CH₄ and drag to the right in a circle six clicks at a certain angle, whereupon the next members of the sequence will appear, closing the six-membered ring. It is necessary to select the entire molecule structure by clicking on  in the upper left corner of the interface, and then, by adjusting the molecule selection mode by clicking on , this icon is displayed: . Drag and select the entire molecule, select the *Clean Structure* icon (), or perform the sequence of actions shown in **Figure 2a**, which gives the cyclohexane structure with adjusted bond angles shown in **Figure 2b**.

Figure 3. Skeletal formula of benzene

STEP 6

Click on any carbon atom in the benzene ring to add a methyl group to the existing structure of the compound (**Figure 4**). By clicking on the carbon atom from the methyl group, it is possible to draw the ethyl group from the methyl group (**Figure 5**).

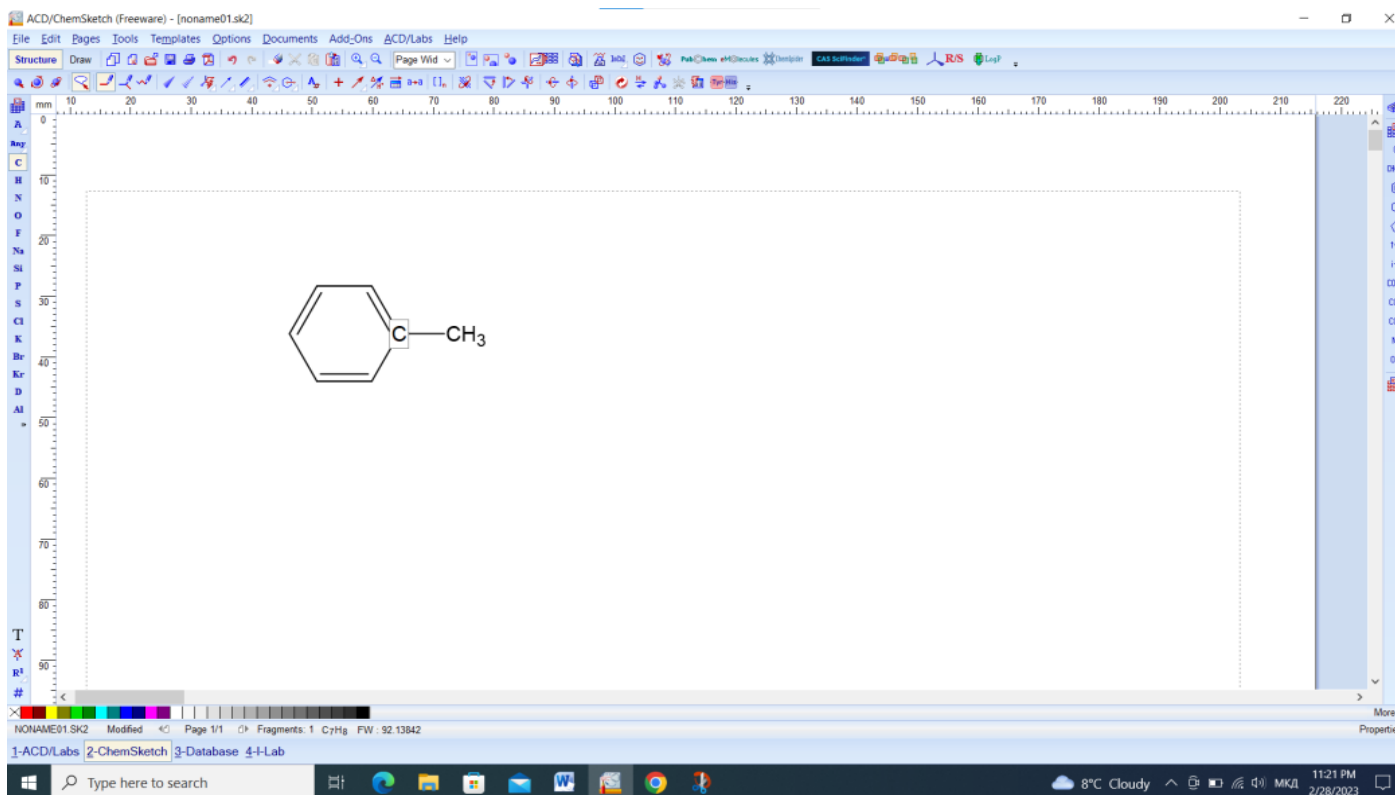

Figure 4. Structure of methylbenzene (toluene)

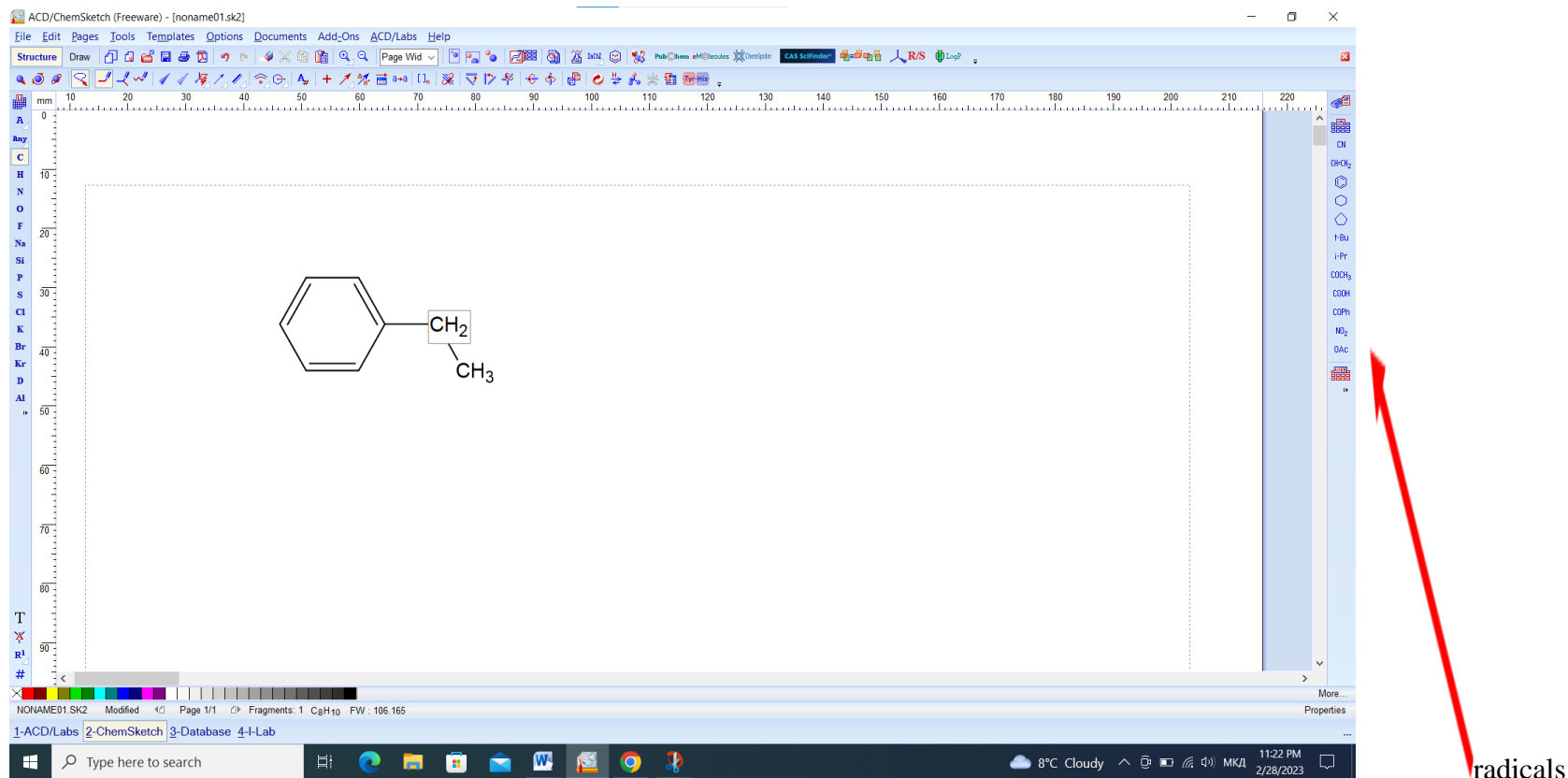

Figure 5. Structure of the ethylbenzene molecule

STEP 7

On the right side of the interface, you can find a table of radicals (alkyl groups) that contains the most frequently needed radicals (alkyl groups) for quick structure drawing. Use the *Charges/Radicals* toolset from the *Atom Toolbar* to change or draw new alkyl groups.

Example 2.

STEP 1 Try to draw the monosubstituted benzene derivatives shown in **Figure 6** and the disubstituted and trisubstituted benzene derivatives shown in **Figure 7**. Draw the above mentioned as described in **STEPS 1-7** of **example 1**.

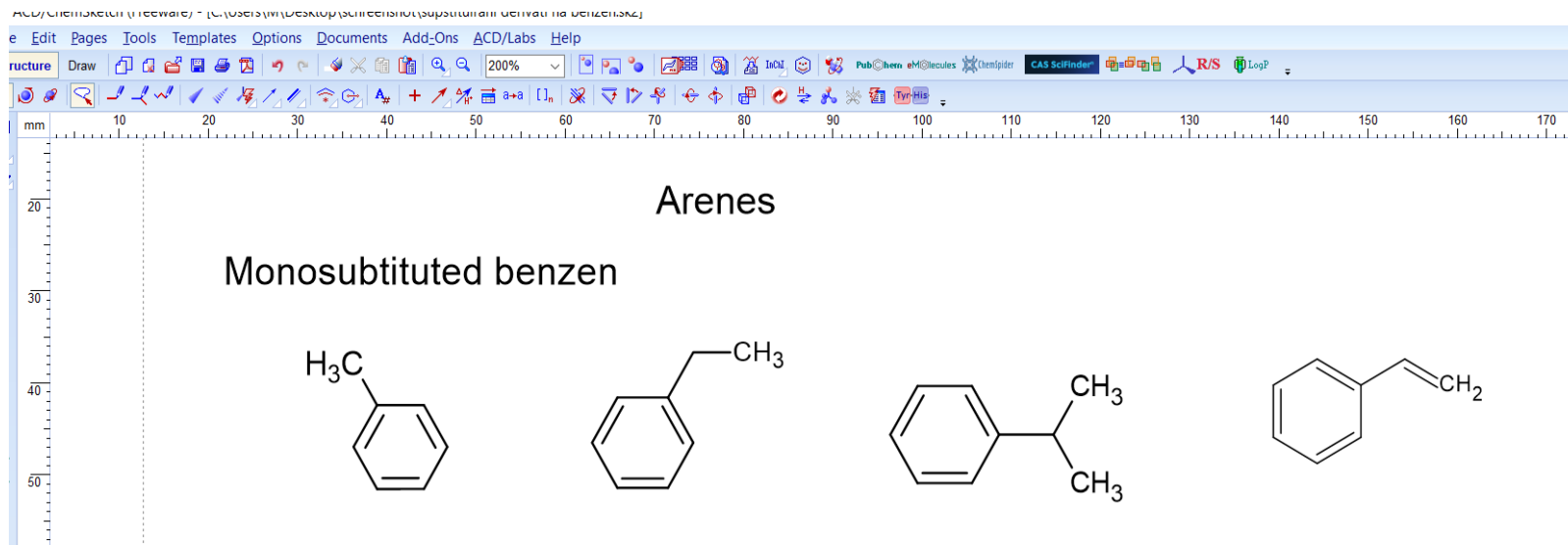

Figure 6. Molecular structures of monosubstituted benzene derivatives

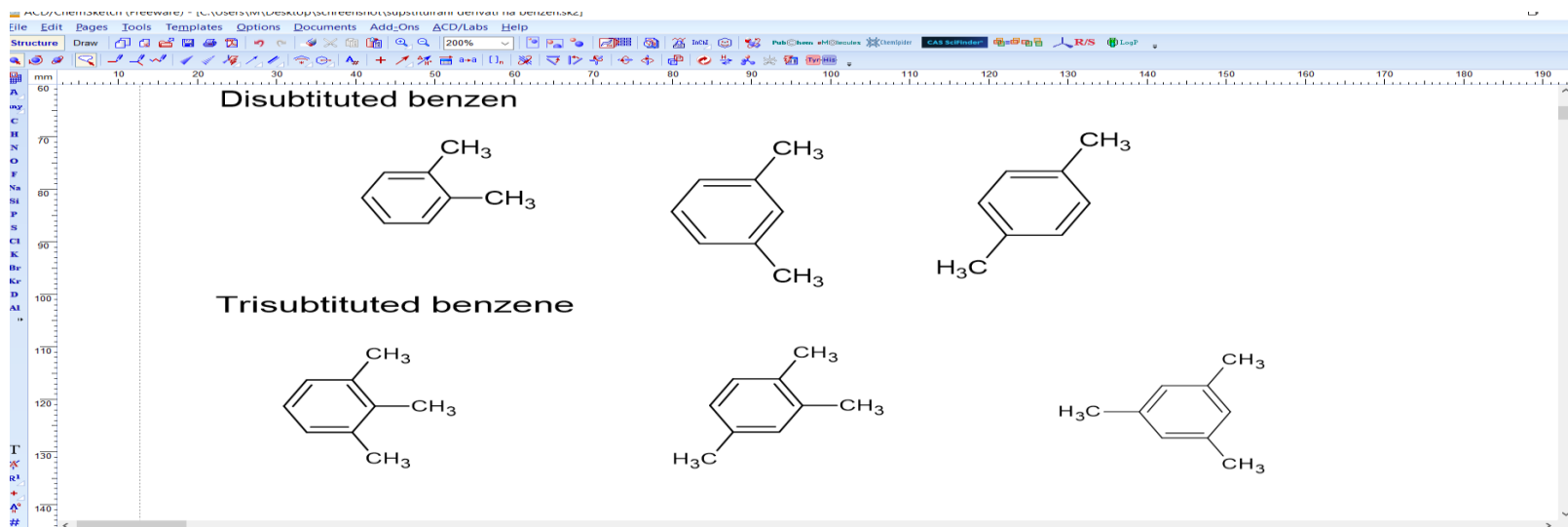



Figure 7. Molecular structures of disubstituted and trisubstituted benzene derivatives

STEP 2

Aromatic compounds have several different names used for the same molecule. Systematic (according to IUPAC nomenclature) and common names are distinguished. To name previously drawn molecules, highlight the appropriate molecule by selecting the icon , then select *Tools*, then in the drop-down menu *Generate and Name for Structure*. The mentioned procedure is shown in **Figure 8**, and **Figure 9a** shows the structures of the drawn molecules and their associated names: methylbenzene (toluene), ethylbenzene, isopropylbenzene (cumene), vinylbenzene (styrene), **Figure 9b** shows 1,2-dimethylbenzene (xylene), 1,3-dimethylbenzene and 1,4-dimethylbenzene and **Figure 9c** 1,2,3-trimethylbenzene, 1,2,4-trimethylbenzene and 1,3,5-trimethylbenzene.

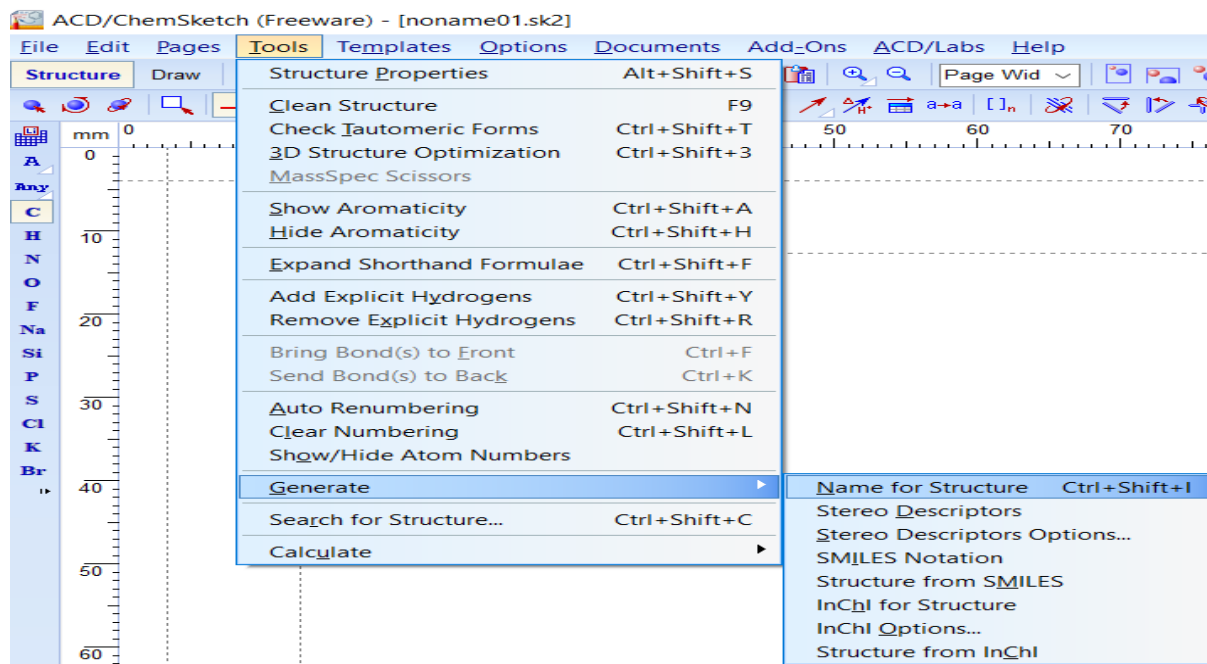
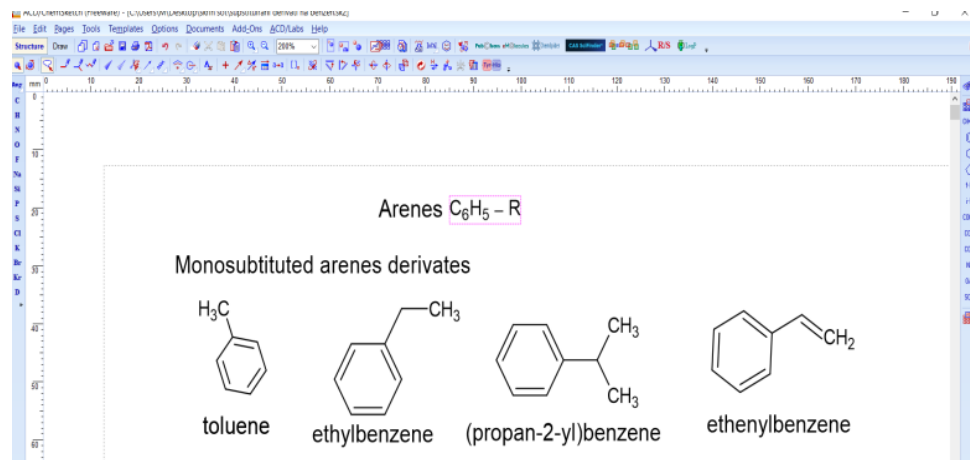
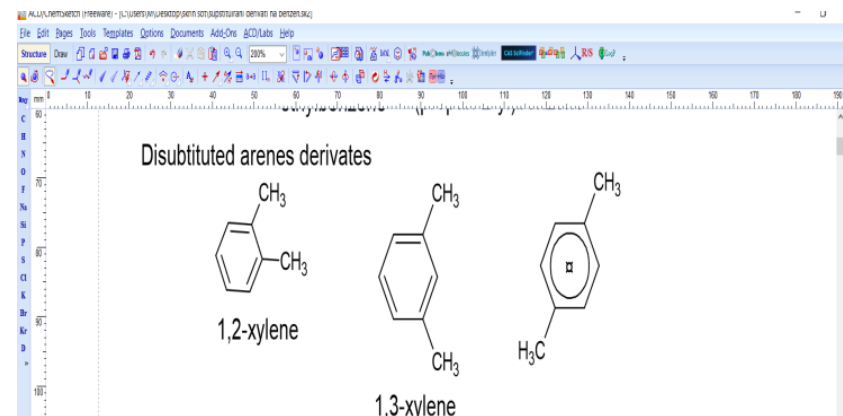

Figure 8. Generating names of drawn compounds



a)



b)

c)

Figure 9. a) Generated names of monosubstituted benzene derivatives, b) generated names of disubstituted benzene derivatives, c) generated names of trisubstituted benzene derivatives

STEP 3 To number the carbon atoms in the compound structure, choose *Tools*, then *Show/Hide Atom Numbers* (**Figure 10**).

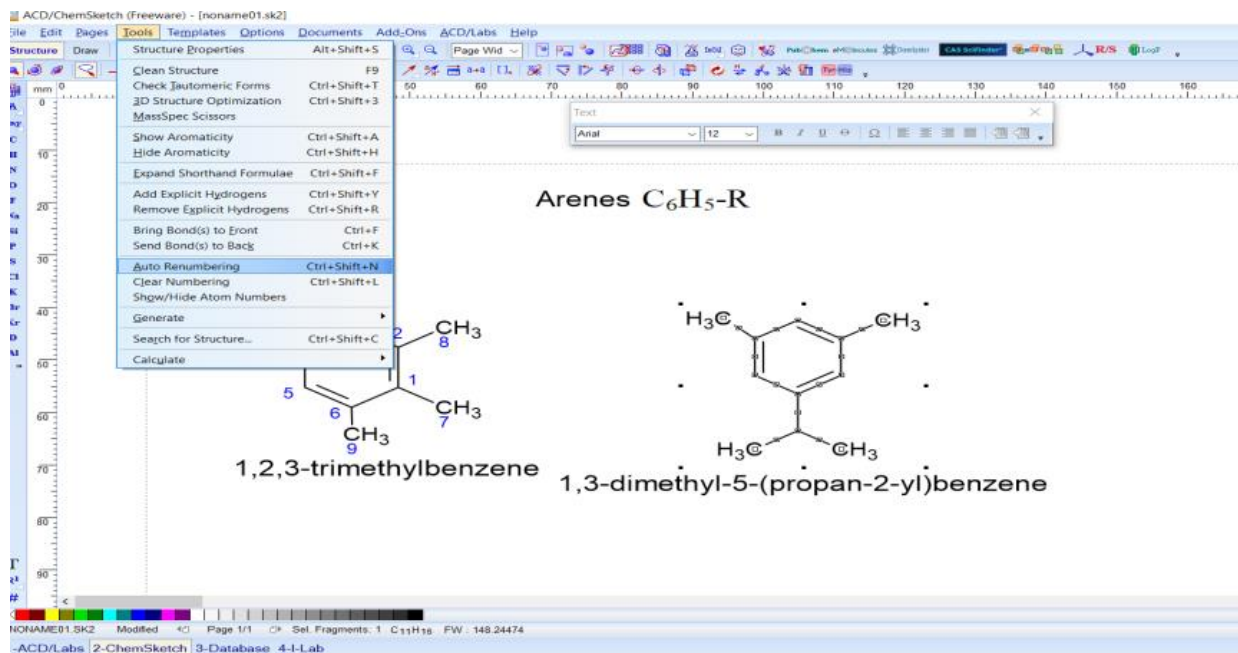

Figure 10. Numbering the carbon atoms in the drawn molecules

STEP 4 Highlight one of the drawn structures and select *Tools*, then *Calculate* and finally *Molecular Formula*, which will generate the molecular formula of the selected compound (**Figure 11a**). The molecular formula of the selected compound is displayed in a new window. To display the molecular formula on the worksheet, which contains the structure and name of the selected molecule structure, select *Copy to Editor*. (**Figure 11b**)

The screenshot shows the ChemSketch interface. On the left, the 'Tools' menu is open, and the 'Calculate' option is selected. A sub-menu is visible with the following options:

- Molecular Formula
- Formula Weight
- Composition
- Molar Refractivity

The main workspace displays several chemical structures with their names and molecular formulas:

- toluene: C_7H_8
- ethylbenzene
- (propan-2-yl)benzene
- ethenylbenzene
- Disubstituted arenes derivatives:
 - 1,2-xylene
 - 1,3-xylene
 - Molecular Formula: C_8H_{10}

A 'Calculation Results' window is open in the bottom right corner, showing the calculated molecular formula: C_8H_{10} .

a)

b)

Figure 11. a) Sequence of actions for calculating the molecular formula of the selected compound structure, b) Window with the calculated molecular formula of the selected compound structure.

STEP 5

To display the structure of the methylbenzene (toluene) molecule with the structural formula, select *Tools*, then *Add Explicit Hydrogens*. After that, select *Clean Structure* to edit the displayed structure, then select *Tools* again, and by clicking *Structure Properties*, a new window will open in which, in the *Show Carbons* section, select the option *All* (**Figure 12**).

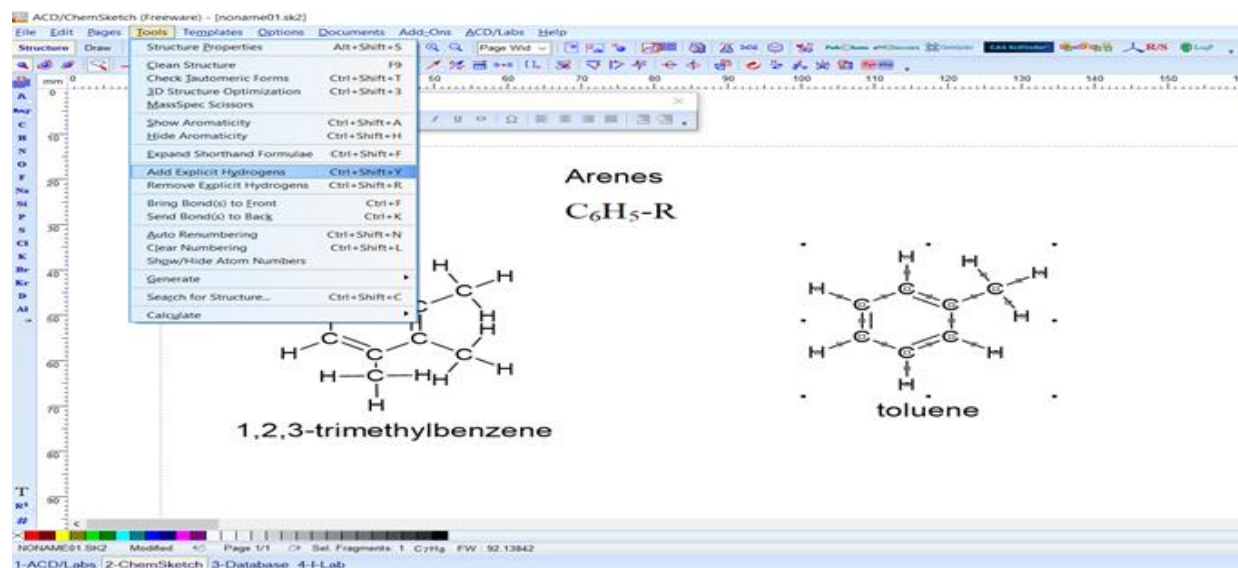

Figure 12. Structural formula of a molecule of methylbenzene (toluene)

STEP 6 Repeat the previously described procedure to show the structural formula of the molecule of 1,3-dimethyl-5-isopropylbenzene (**Figure 13**).

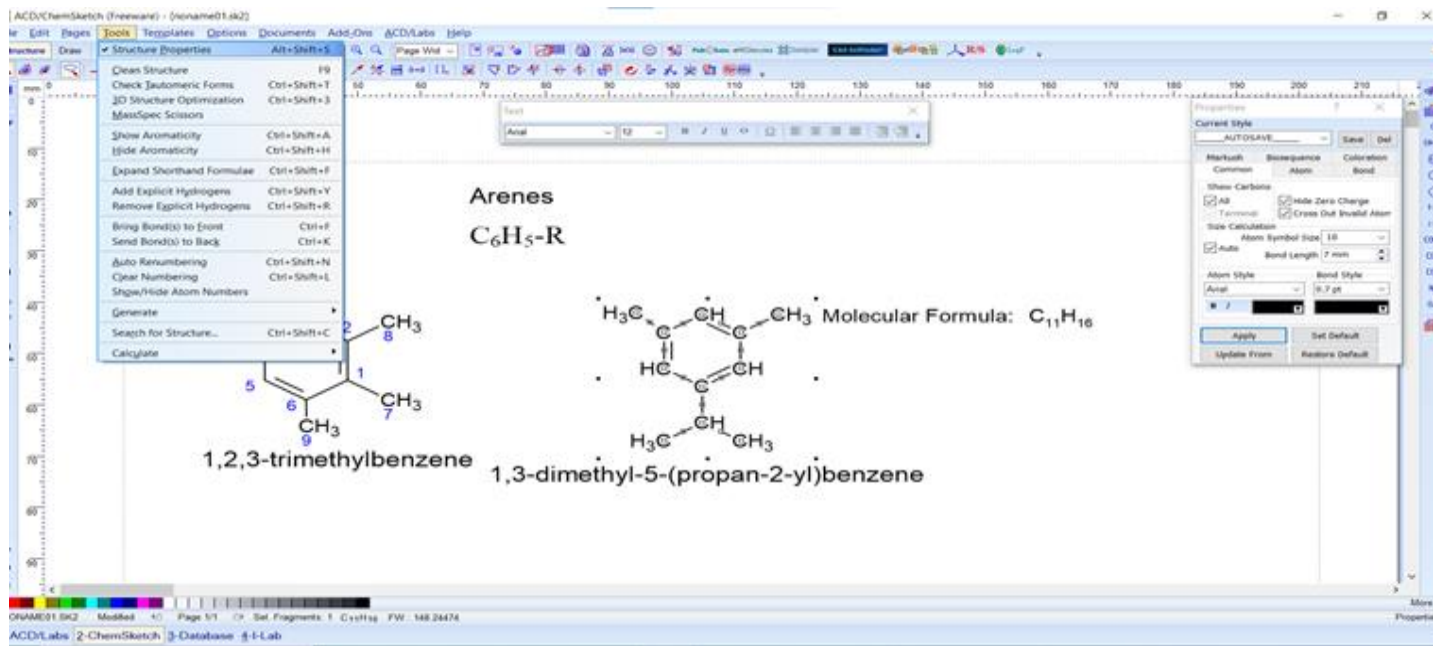



Figure 13. The structural formula of 1,3-dimethyl-5-isopropylbenzene

STEP 7

Display the resulting structural formula for methylbenzene and 1,2,3 trimethylbenzene in three dimensions by first selecting it and then clicking on the  on the toolbar. A new window (*3D Viewer*) will open with a 3D view of the molecule (**Figure 14**). By positioning the mouse icon on each individual atom, its numerical designation according to the IUPAC nomenclature and its coordinates appear.

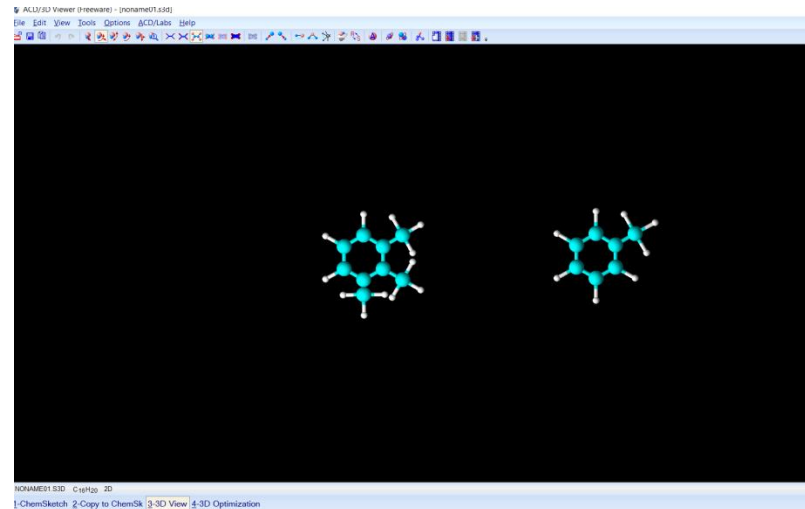
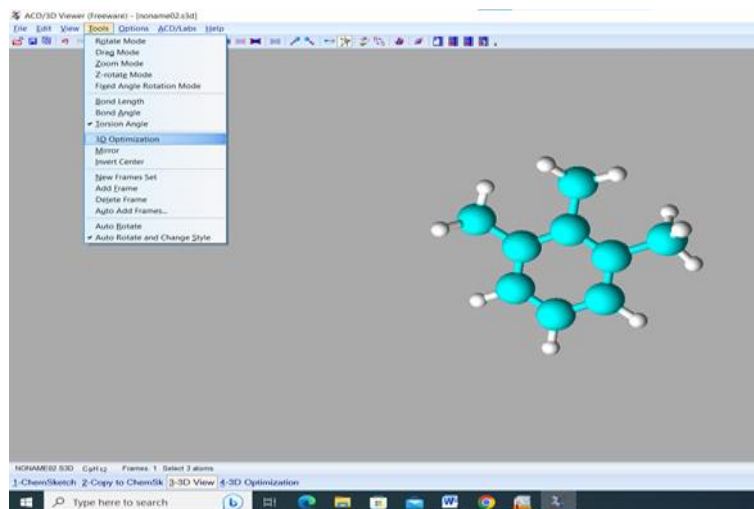



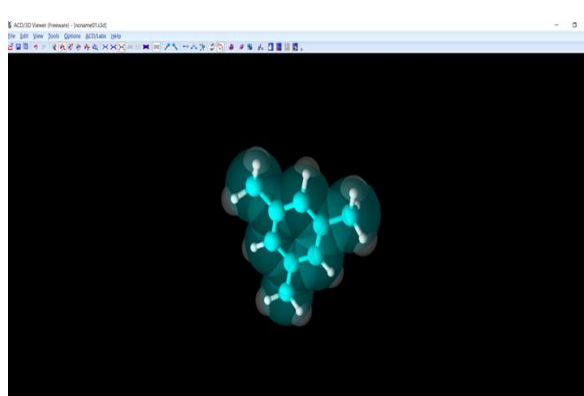
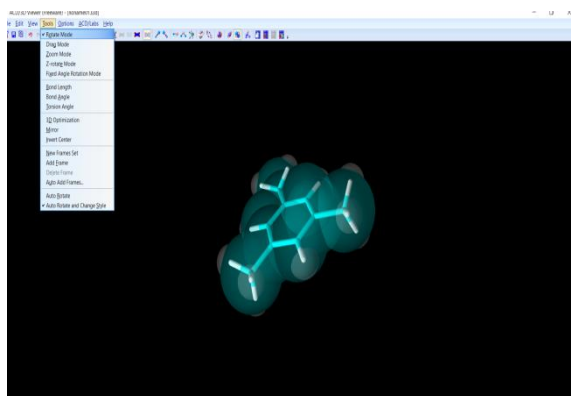

Figure 14. 3D structure of the methylbenzene and 1,2,3 trimethylbenzene molecule

STEP 8 Repeat the process of showing the three-dimensional structure of the molecule using the example of the 1,3,5-trimethylbenzene molecule.

Try using each of the rotate, move, and select options on the top toolbar: , and then display the molecule in each of the ways the program offers, and the options are also displayed on the toolbar: . To automatically rotate the molecule, click the icon.  (**Figure 15 a and b**).



a)

b)

Figure 15. Presentation of the three-dimensional structure of the 1,3,5-trimethylbenzene molecule using sticks (a), using balls and sticks (b) and presentation of the structure from two different angles due to the use of the rotating tool in three dimensions.

4.4. Examples of tasks for processing teaching content

1. Draw all structural isomers of trimethylbenzene. Write the names of all isomers, then choose one and do the following with it:

- draw the formula of the trimethylbenzene molecule,
- generate its name in the program and determine the molecular formula of that molecule,
- show it with skeletal formula, structural and condensed structural formula,
- show the structure of the molecule in three dimensions in different ways,
- determine the lengths of the selected bonds and specific bond angles,
- optimize the molecule,
- rotate and move it in two and three dimensions,
- save the 2D and 3D structure to the computer,
- determine the molecular formula, switch to three dimensions, save both 2D and 3D structure of the molecule.

2. Explore the application of arenes in everyday life. Select one molecule to display in the *ChemSketch* program. Write in your notebook the application of the chosen molecule in everyday life. Save the optimized 2D and 3D structure of these molecules to your computer.

4.5. Examples of student evaluation tasks

1. Draw all structural isomers of xylene. Write the names of all isomers, then choose one and do the following with it:

- generate the name,
- determine the molecular formula,

- c) show the structure with skeletal formula, structural and condensed structural formula,
- d) edit the structure of the molecule with the *Clean Structure* option,
- e) display the structure of the molecule in the *3D Viewer*,
- f) display the structure of the molecule in the *3D Viewer* using sticks and balls,
- g) optimize the molecule,
- h) save both the 2D and 3D structure of the molecule on the computer,
- i) open the 2D structure of the molecule and make a cyclic structure from it and generate its name and molecular formula.

LEWIS STRUCTURES

1.) ELABORATION OF THE UNIT TITLE

Teaching unit: Lewis Structures
Unit title: Drawing Lewis Structures
Estimated number of hours: 2

1.1. Theoretical introduction

Lewis structural formulas are ways of binding atoms in a molecule by dots representing common pairs of electrons or unpaired electrons.

When drawing Lewis structural formulas, certain rules explained below are used:

1. It is necessary to determine the total number of valence electrons in a molecule or ion.
2. Atoms should be arranged in the "*skeleton*" of the molecule:
 - hydrogen atoms are always peripheral or external atoms because they can only bind by a single covalent bond,
 - the central atom of the remaining is the one with the lowest electronegativity coefficient.
3. The remaining atoms should be bound by a single covalent bond to the central atom. For this bond, a certain number of electrons were used, which should be subtracted from the total number of valence electrons. The remaining valence electrons need to be distributed as non-bonded electron pairs to the octet with more electronegative atoms.

4. It is necessary to check that all atoms have achieved the appropriate configuration of noble gas (duplet, octet). If the central atom has not reached an octet, then it is necessary to form multiple bonds by means of non-bond pairs from peripheral atoms until the octet is reached.

5. It is necessary to check whether the number of midfield pairs corresponds to the valence of the central atom.

Valence Shell Electron Pair Repulsion (VSEPR) theory is a model used in chemistry to predict the geometry of individual molecules from the number of electron pairs surrounding their central atoms. VSEPR theory is used to predict the arrangement of electron pairs around central atoms in molecules, especially simple and symmetric molecules. A central atom is defined in this theory as an atom which is bonded to two or more other atoms, while a terminal atom is bonded to only one other atom.

1.2. Educational Outcomes

- to visualize atoms, molecules, or ions with Lewis symbols
- to explain the spatial arrangement of particles in elementary substances and molecules of chemical compounds by applying VSEPR theory
- to calculate the bond angle between two atoms in drawn molecules.
- To visualize drawn molecules or ions in a 3D model
- To name organic and inorganic compounds using the *ChemSketch* program.
- To use ready-made complex ion templates found in *ChemSketch*.
- To apply VSEPR theory when determining the spatial shape of molecules or ions.

1.3. Instructions for Using the *ChemSketch* Program

A) As the first example, we will study how to draw the Lewis structural formula of a water molecule (H₂O)

STEP 1 On the left toolbar in the *Periodic Table of Elements*, an oxygen atom is selected and clicked onto empty space within the drawing area.

(The molecular formula of the water molecule will appear).

STEP 2 It is necessary to mark the resulting structure, then click *Tools* and *3D Structure Optimisation*.

STEP 3 We mark the structure of the drawn molecule again, click *Options*, then *Set Structure Drawing Style* and then click *Normal*. The mentioned procedure is shown in **Figure 1**.

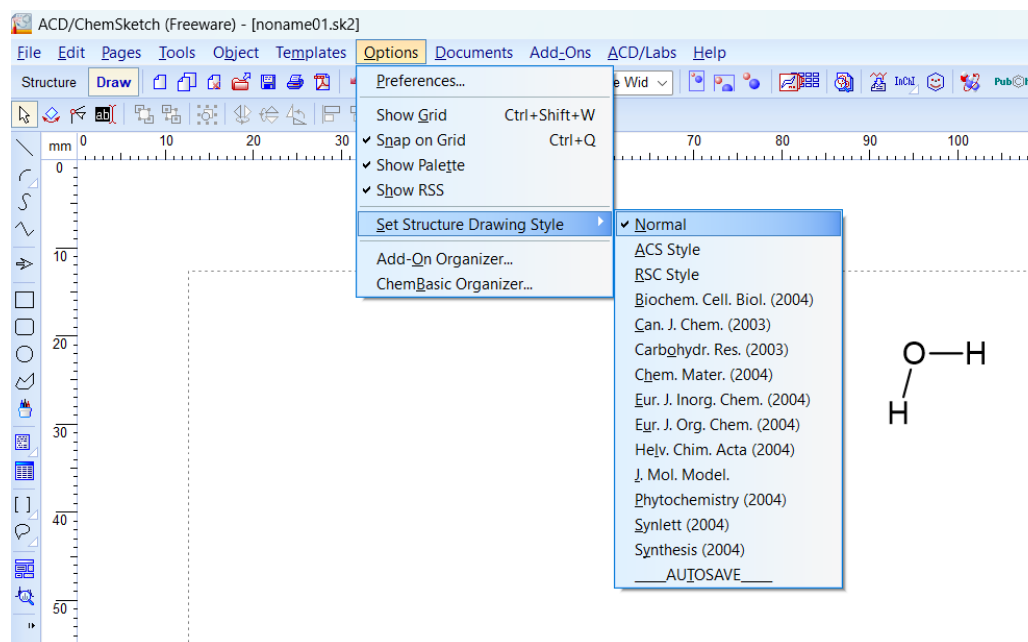

Figure 1. Optimisation of the drawn structure.

STEP 4 For a better overview of Lewis structural formulas, once we have drawn the desired molecule, we can click *Fit all* to enlarge the image.

STEP 5 In order to draw Lewis structural formula of the water molecule, it is necessary to click on *Templates* and then *Templates Window* after which we open a window showing Lewis dots. The mentioned procedure is shown in **Figure 2**.

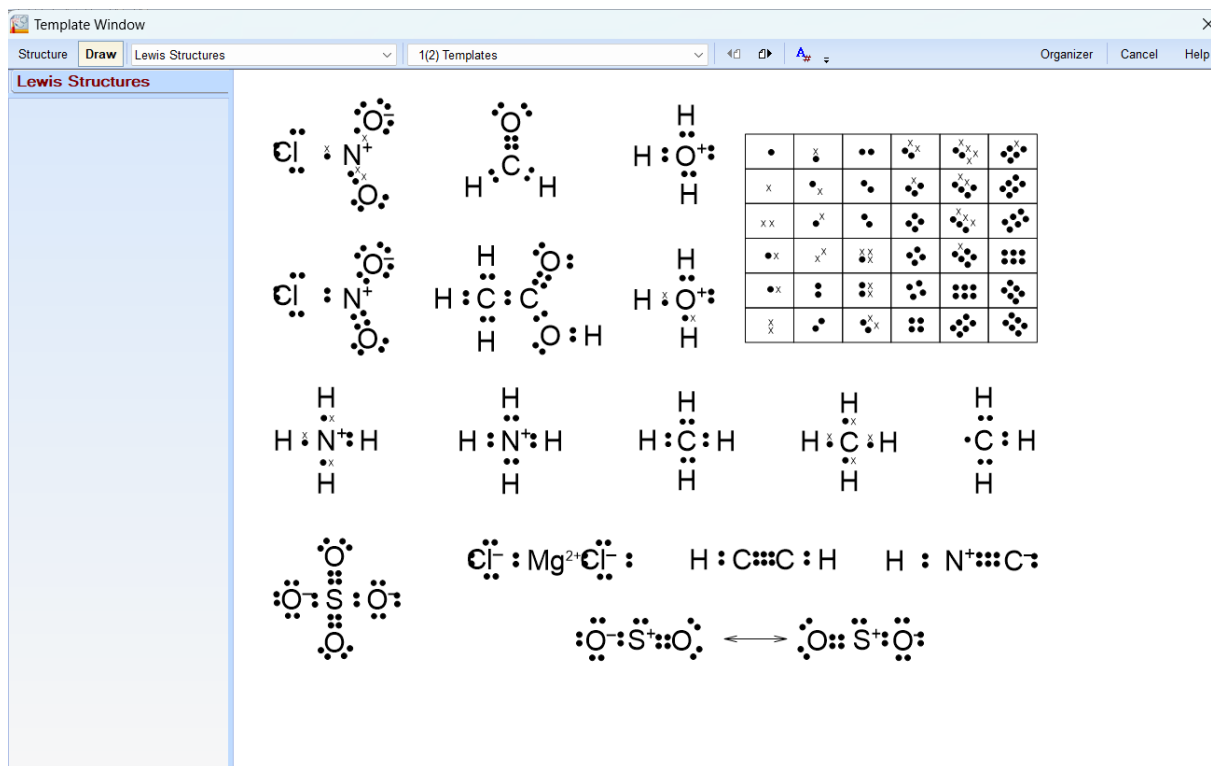

Figure 2. Window for adding Lewis dots to the depiction of the drawn molecule.

STEP 6 In the upper right window, you need to select a specific way of displaying Lewis dots and click next to the atom they are joining.

STEP 7 With the *Selection Option*, we can reduce the added Lewis dots, while with the *Rotation Option* we can rotate them so that they are placed in the correct orientation next to the atom.

STEP 8 Following these steps, we obtained the Lewis structural formula of a water molecule.

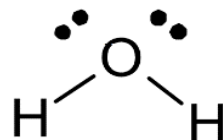

Figure 3. Lewis structure of a water molecule.

STEP 9 In the next step, we will show the 3D structure of a water molecule. In this section, we will repeat steps 1-4.

After that, we select the drawn molecule and click *Tools* and then *3D Structure Optimization*. The mentioned procedure is shown in **Figure 4**.

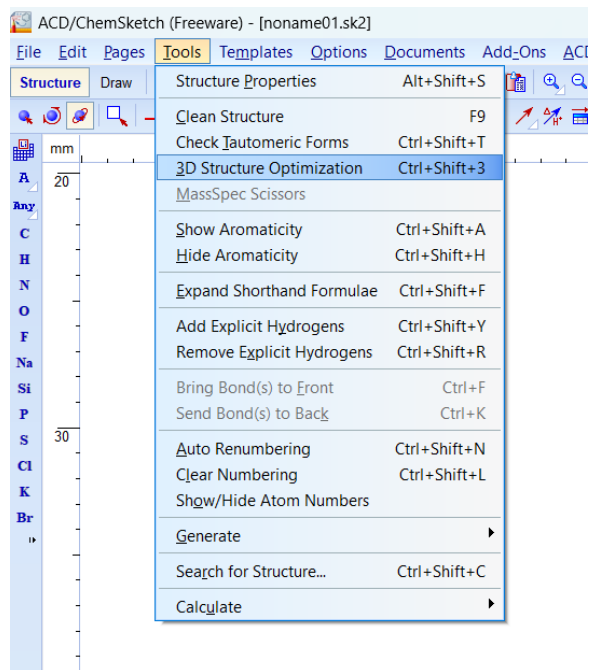

Figure 4. 3D optimization of the drawn structure.

STEP 10 After doing the necessary actions, we click the *3D viewer* on the top toolbar. A new window will open with the 3D structure of the molecule. The mentioned procedure is shown in **Figure 5**.

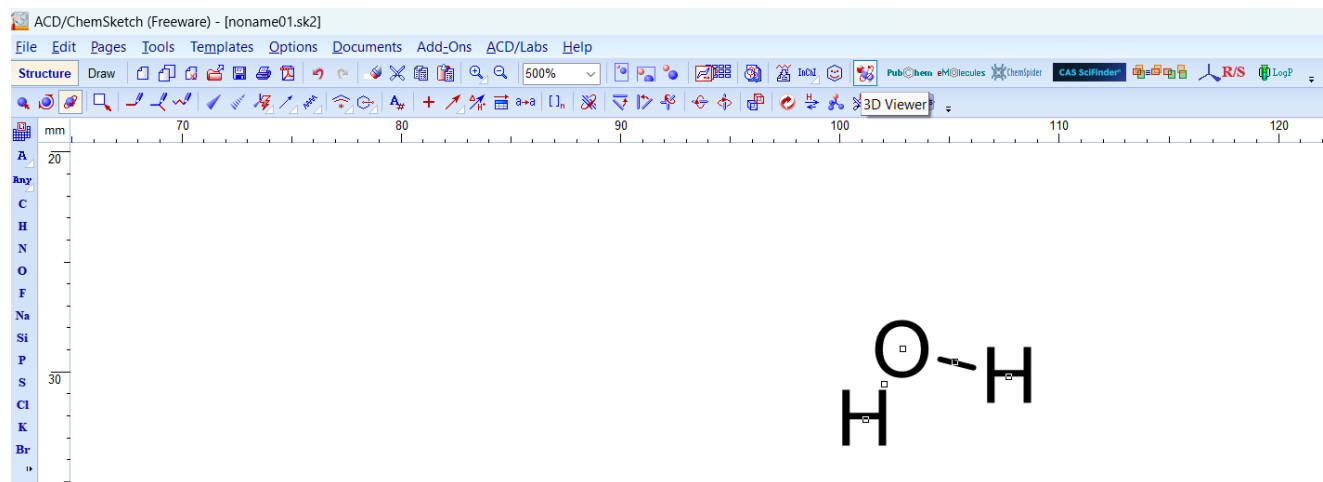

Figure 5. Switching the structure to 3D view.

STEP 11 In a 3D window, the molecule can be rotated in all directions and thus the spatial structure of the molecule itself can be studied.

STEP 12 In order to calculate the covalent angle between two covalent bonds in a molecule, it is necessary to choose the *Bond angle* option. The mentioned procedure is shown in **Figure 6**.

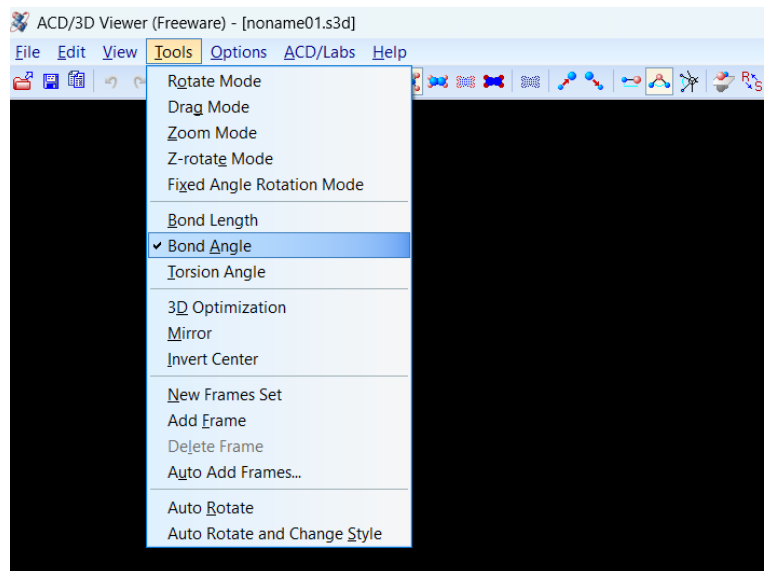

Figure 6. Calculating the covalent angle between two covalent bonds in a water molecule.

STEP 13 After the previous step, it is necessary to click first on the hydrogen atom (click to change the color to green) then the oxygen atom and, finally, the second hydrogen atom. A window will open and show the covalent angle within the water molecule.

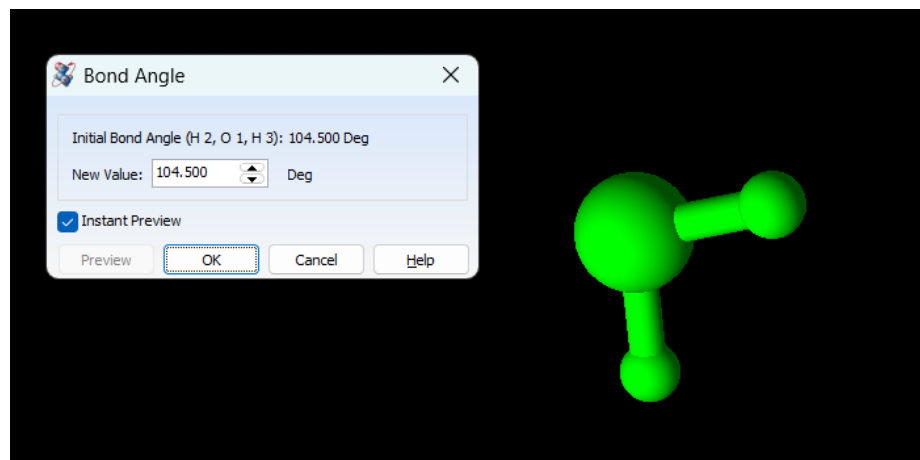

Figure 7. The values of the covalent angle between two covalent bonds.

STEP 14 Based on the presented 3D structure of the molecule, it is necessary to know the VSEPR theory to determine the shape of the molecule.

In the same way as described for the water molecule, **methane molecules** and **ammonia molecules** can also be shown in the teaching process. It is necessary to follow the same steps explained in the presentation of Lewis structural formula of the water molecule.

The ammonia molecule can be represented by selecting nitrogen atoms in the left toolbar on which the atoms of individual elements are located, while the methane molecule can be represented by selecting carbon atoms. By clicking on the empty area of the program, the molecular formula of the compound is displayed, and following the steps above to display the water molecule, Lewis structural formulas of these compounds can be displayed as well as their corresponding 3D structures.

B) As the second example, we will study how to draw the Lewis structural formula of a **SULFATE ANION**.

STEP 1 In the top toolbar, click on *Template* and select *Template Window*. After that, a window opens in which we select anions for the display area in the left field and in the right field we select inorganic. The mentioned procedure is shown in **Figure 8**.

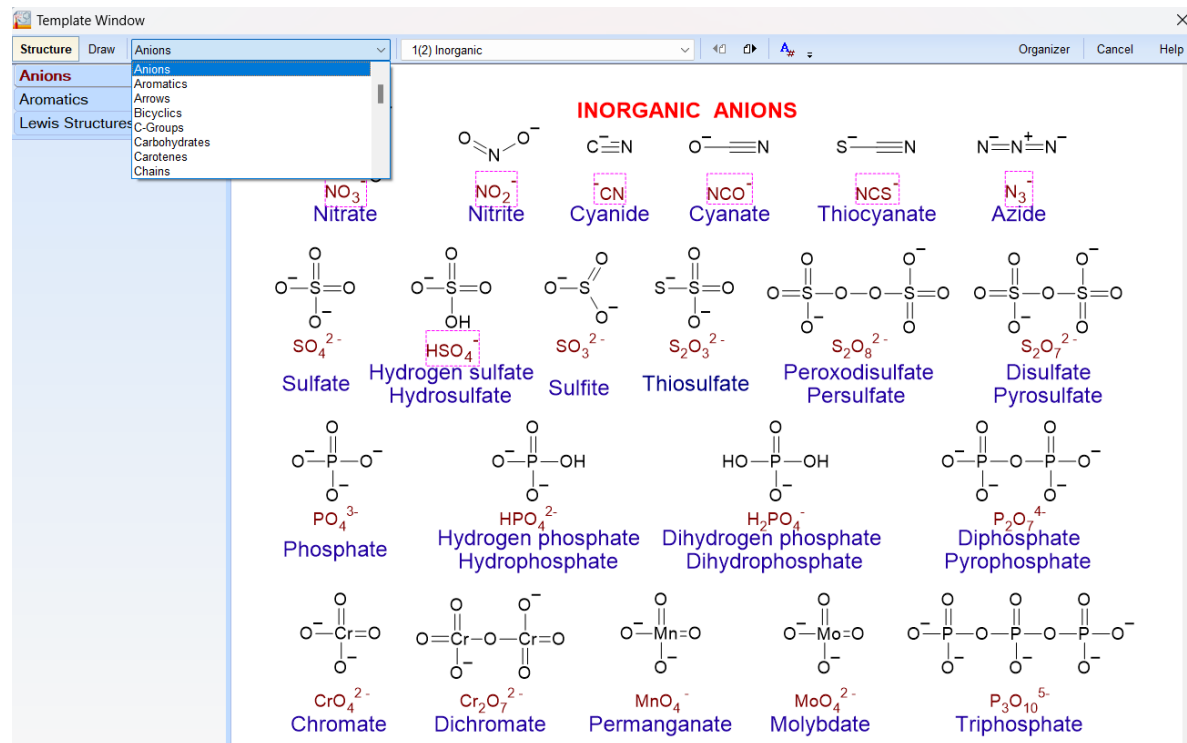

Figure 8. Window with inorganic anion templates

STEP 2 In the window that opens, we select the anion for which we want to display the structural formula. In this case, it is the sulfate anion. Click on the selected anion, the window will close, then click on the specified anion to the area for drawing structures.

STEP 3 We mark the drawn anion and click *Tools* and then *3D Structure Optimization*. The mentioned procedure is shown in **Figure 9**.

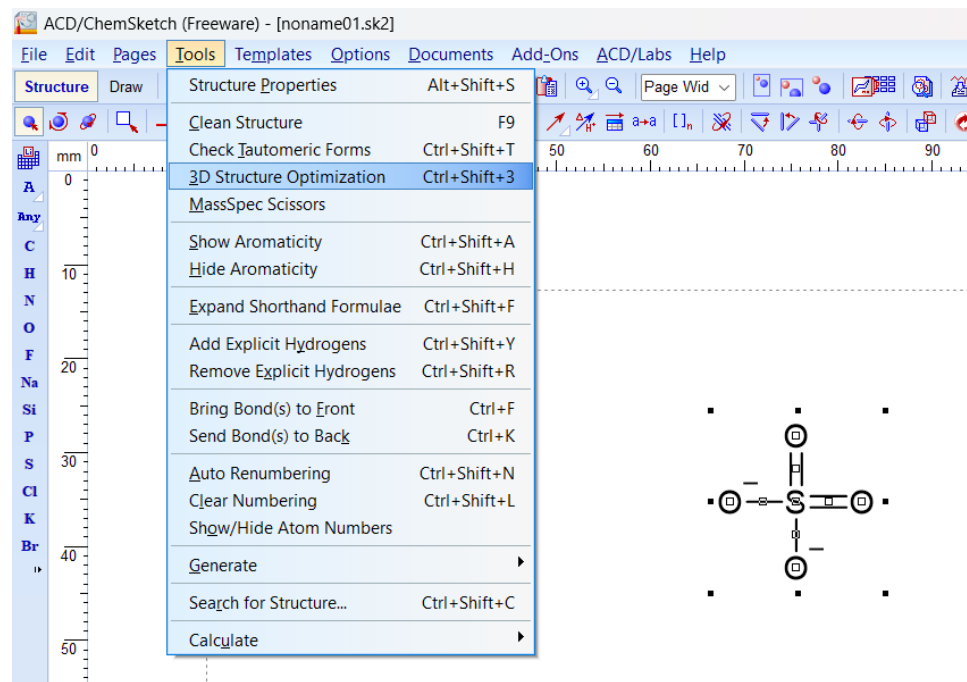

Figure 9. Drawing inorganic anions

STEP 4 The presented structural formula is drawn as a Lewis structural formula in the same way as the water molecule.

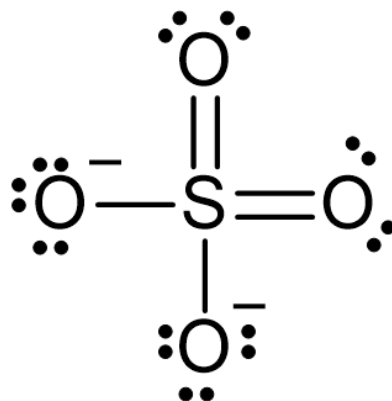

Figure 10. Lewis structural formula of sulfate anion

STEP 5 After that, in the upper tool, click the option of switching the drawn molecule into a 3D view - *3D Viewer*, which shows the 3D structure of the anion and the spatial arrangement of the atoms in the drawn anion.

The presented 3D structure of the molecule can be rotated in all directions and thus the arrangement of atoms in space can be studied.

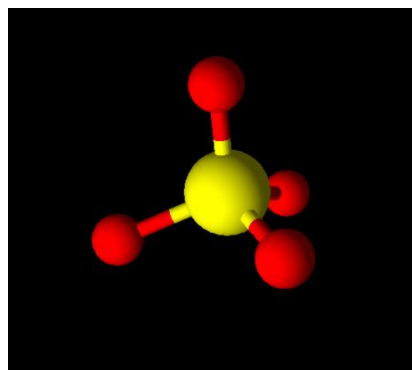

Figure 11. 3D view of a sulfate anion

STEP 6 For the presented molecule, the covalent angle can be determined, and by knowing the VSEPR theory, the shape can also be determined.

1.4. Examples of Tasks for Processing Teaching Content

1. Draw Lewis structural formulas of the following molecules: carbon (IV) oxide and sulphur (IV) oxide.
 - a) display these molecules in 3D structure,
 - b) determine the covalent angle,
 - c) determine the shape of the molecule by knowing the VSEPR theory.

2. Draw Lewis structural formulas of the following ions: nitrite and sulfite.
 - d) display these ions in 3D structure,
 - e) determine the covalent angle,
 - f) determine the shape of the ions by knowing VSEPR theory.

3. Research and select one molecule that is essential in our everyday life. Draw the selected molecule in *ChemSketch* and show the Lewis structural formula. Present the selected molecule in a 3D structure and study its spatial structure.

1.5. Examples of Students Evaluation Tasks

4. Draw Lewis structural formula of the sulphuric acid.
 - g) display the molecule in 3D structure,
 - h) determine the covalent angle,
 - i) determine the shape of the molecule by knowing VSEPR theory.

CHIRALITY AND OPTICAL ACTIVITY

1.) ELABORATION OF THE UNIT TITLE

Teaching unit: Chirality and Optical Activity
Unit title: Chirality and Optical Activity
Estimated number of hours: 2

1.1. Theoretical introduction

Chirality and optical activity

Optical activity is related to the internal spatial arrangement of atoms in a molecule.

There are pairs of molecules that are in the same relationship to each other as an object and its image in a mirror.

Optical activity occurs in a wide range of organic and inorganic complex compounds. Organic carbon compounds are the most common optically active substances. The condition for optical activity is the fact that four different substituents are attached to the carbon atom.

Such a carbon atom is called asymmetric (chiral = *chiro* = from the Greek word hand) carbon (chiral center of the molecule). The incompatibility of an object with its mirror image is called chirality.

Pairs of substances that contain optically active carbon and occur in two forms (object-image) are called enantiomers, formerly optical antipodes.

If the molecule contains more centers of chirality, the number of enantiomers increases.

For structures with acyclic chains, the number of optical antipodes is equal to 2^n , where n is the number of chiral centers of the molecules.

With a larger number of asymmetric atoms, some isomers may be symmetrical as a whole. An example are tartaric acid isomers with two identical centers of chirality in the molecule.

Designation of enantiomers

Enantiomers that turn the plane of polarized light to the right are called dextrorotatory and are marked with a + sign.

Enantiomers that turn the plane of polarized light to the left are called levorotatory and denoted by the sign -.

An equimolar mixture of both enantiomers is called a racemic mixture (racemate) and there is no bending of light (the contributions of + and - enantiomers are compensated).

D-; L-enantiomers

In a large number of cases, the signs of the rotation are just a physical constant, and the relationship between it and the structure is difficult to define.

For this reason, standards were introduced by which individual configurations on asymmetric centers are compared.

In the chemistry of sugars, this standard is glyceraldehyde – its dextrorotatory antipode was marked with the symbol D- and the levorotatory L-.

In the chemistry of amino acids and proteins, this standard is alanine - its dextrorotatory antipode was designated by the symbol D- and the left-handed antipode L-.

Since this notation did not suit, chemists agreed to express the absolute configuration of systems using the Cahn-Ingold-Prelog R,S-system, according to which each center of chirality is designated separately.

(R comes from Latin *rectus*, right; S from Latin *sinister*, left).

Source: Mareček, A., Honza, J. Chemistry for four-year high schools, volume 3. 1st ed. Olomouc: Nakladatelství Olomouc 2000. 250 pp. ISBN 80-7182-057-1

1.2. Educational Outcomes

- to describe the concept of chirality, optical activity, enantiomers
- to determine the chirality compound according to its structural formula
- to draw structural and skeletal formulas of various chiral compounds
- to generate the names of drawn compounds in *ChemSketch*
- to generate molecular formulas of compounds
- to optimize the formulas using the *Clean Structure* function in the *ChemSketch* program
- to draw the optical isomers of the compounds formed
- to mark the chirality center in the structure of compound

- to display structure of chiral compounds in three dimensions
- to observe structures of compounds from different angles
- to rotate and move the drawn structure in 2D and 3D
- to determine bond lengths and bond angles of different chiral compounds
- to save the created 2D and 3D structures to the computer

1.3. Instructions for Using the *ChemSketch* Program

STEP 1

In working space *Structure*



select the *Draw Normal*



drawing option (the *Draw Normal* icon is selected by default unless you selected another *Structure* bar icon after starting the program).

STEP 2

Select the carbon atom  on the Atom *toolbar* (also selected by default).

Left click in the free workspace to render CH₄ (**Figure 1**).



Figure 1. Atom selection

STEP 3

Table of Radicals  on the substituents bar – after activating, you can choose from several possible substituents – select the carboxyl group COOH and connect it to methane (**Figure 2.**)

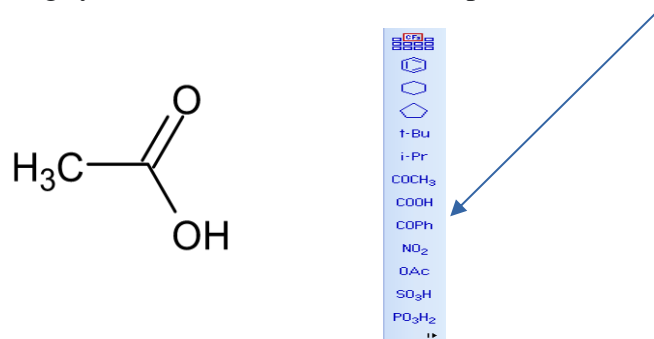

Figure 2. Choice of substituent

STEP 4

From the *Atom toolbar* select  and connect three CH_3 groups to the last carbon on the left (**Figure 3.**):

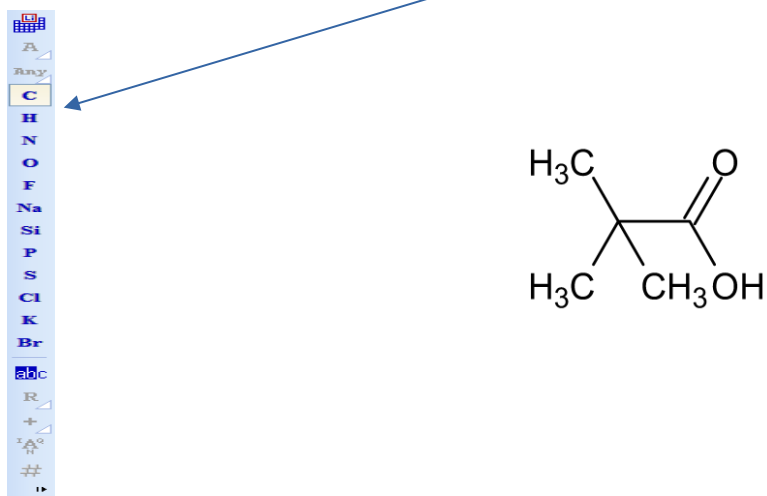

Figure 3. Addition of substituents

STEP 5

From the *Atom toolbar*, select H and O in turn, replace the 2 groups CH₃ for group OH and H (**Figure 4.**)

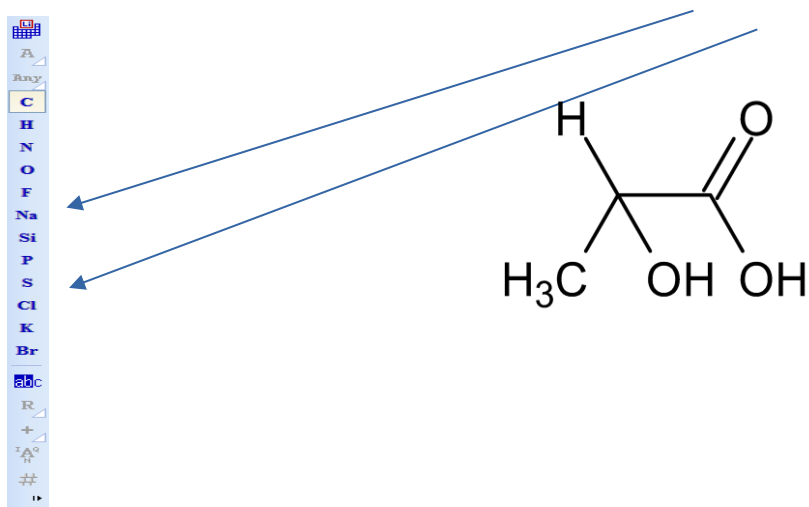

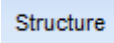



Figure 4. Addition of substituents

STEP 6

Using the icon *Select/Move* , mark the formula (click in the space inside the rectangular area defined by the outermost atoms of the structure), select the working space *Draw*   and select the  *Rotate 90°* icon (rotation by 90°) (**Figure 5.**)

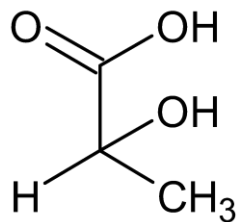

Figure 5. Rotation of the formula

STEP 7

Select the working space *Structure*

Structure Draw

By successfully clicking on the OH, H and CH₃ group move the groups into the required position (**Figure 6.**) - D-lactic acid (D-2-hydroxypropanoic acid)

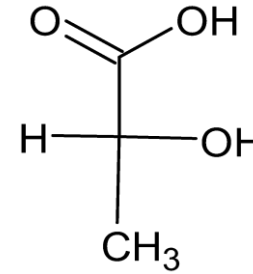
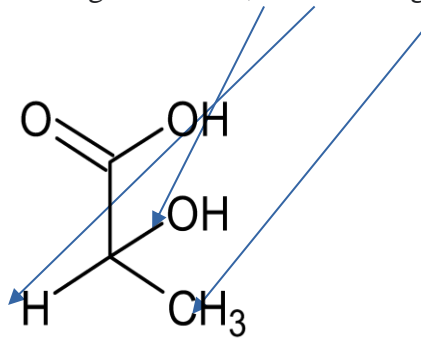

Figure 6. Structure adjustment

Enantiomers are designated according to the characteristic group (hydroxy) orientation on the asymmetric carbon (**Figure 7**) - L-lactic acid (L-2-hydroxypropanoic acid)

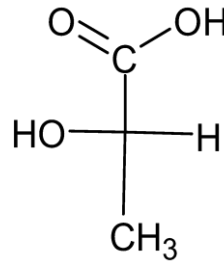



Figure 7. Designation of enantiomers

STEP 8

Select *Menu Tools – Generate – Name for Structure* (or select the icon  on the main toolbar) - the English structure name will be generated according to the IUPAC nomenclature (**Figure 8**) - (2-hydroxypropanoic acid)

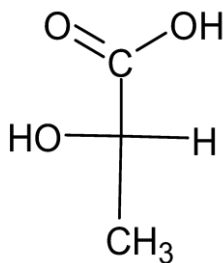



Figure 8. Structure name

STEP 9

If a chiral carbon needs to be marked, select the icon *Edit Atom Label*  on the atom toolbar, click on the chiral center (carbon), a table *Edit Label* will appear, select or write in it C* and select *Insert* (**Figure 9**.)

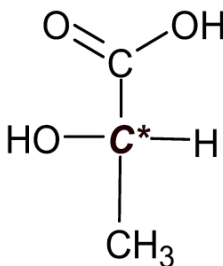

Figure 9. Designation of asymmetric carbon

STEP 10

Created structures can be optimized using the *Clean Structure* function. (**Figure 10**)

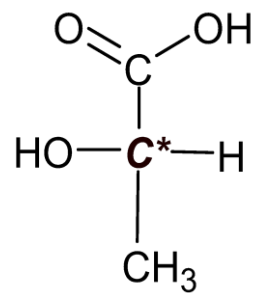
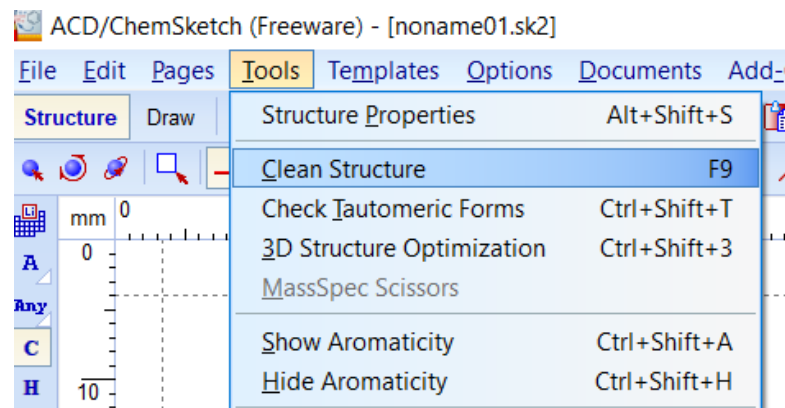

Figure10. Formula optimization

STEP 11

3D Viewer application is used to visualize chemical structures in 3D space. Activate it in the menu in the top bar *ACD/Labs*. In the lower left corner there are buttons to switch between *ChemSketch* and *3D Viewer* applications. Select the drawn structure and optimize it for 3D visualization using the icon *3D Optimization*:



Select the optimized structure and using the *3D Viewer*  icon in the upper right side of the main bar, copy the structure into *3D Viewer* (**Figure 11**).

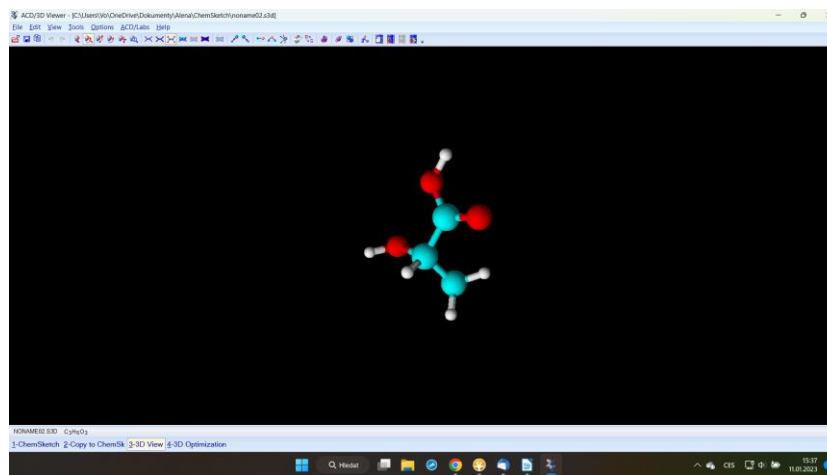
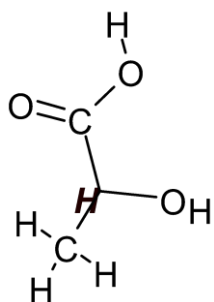

Figure 11. Formula in 3D space

STEP 12

In the drawn formula, you can hide or keep all atoms in the formulas - create a complete or simplified structural formula. In the main bar, select *Tools - Structure Properties* (as shown in Figure 12a). If you want to return to the original formula - click on the *All option* and *Apply* icon.

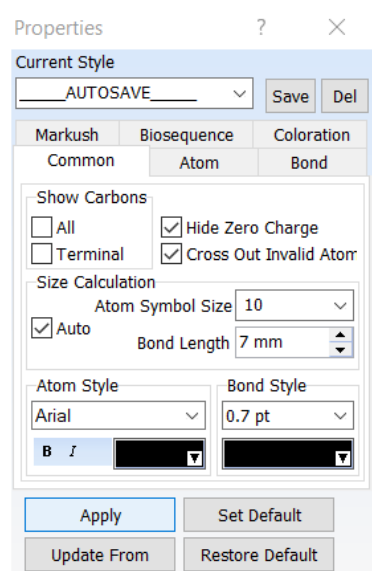

Figure 12b. Current style

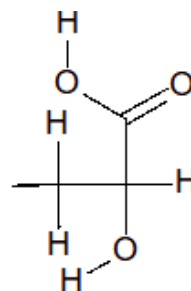

Figure 12a. Simplified structural formula

To display all hydrogens in the molecule, select *Tools* in the main bar and - *Add Explicit Hydrogens* - **Figure 12c**. To get back, click on *Tools* and *Remove Explicit Hydrogens*.

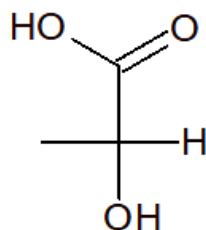













Figure 12c. Completely structural formula

STEP 13

Try different ways to display a molecule in *3D Viewer*.

Click on the *3D Viewer* icon . Show the bonds different views by clicking on the icons       , try automatic molecule rotation by clicking on the icon  and other possible rotations . Click the icon  to smoothly change from one molecule mode to another with rotation.

STEP 14

The bond angle and the bond length determination

The bond length determination: click on the *3D Viewer*  then  and click on the atoms between which you want to determine the bond length - the window shows the length of the selected bond (**Figure 13**).

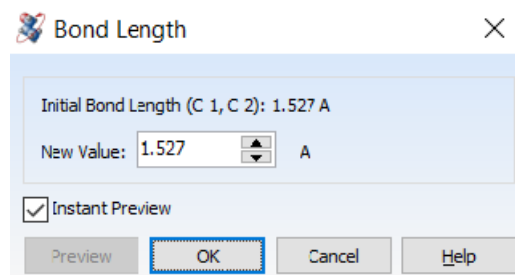

Figure 13. Bond length

The bond angle determination: click on the *3D Viewer*  then  and click on the atoms between which you want to determine the bond angle - the window shows the bond angle (**Figure 14**).

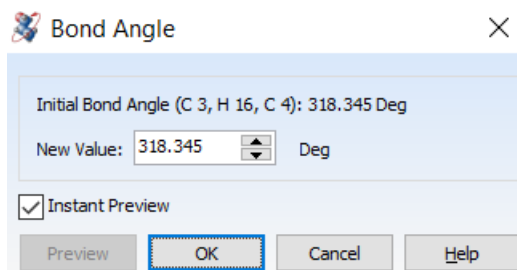

Figure 14. Bond angle

STEP 15

Creating the molecular formula and other compound properties.

Select *Tools - Calculate - Molecular Formula*.

To display the molecular formula on a new sheet with the structure and the name of the drawn molecule, click on *Copy to Editor*. You can also select other items from the menu - molar mass, etc. (**Figure 15**)

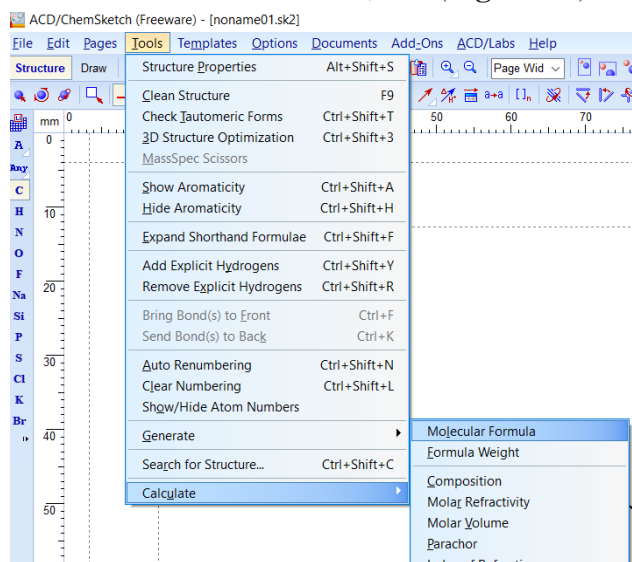

Molecular Formula: $C_3H_6O_3$

Formula Weight: 90.07794

Figure 15. Creating a molecular formula

STEP 16

Save the created structure to your computer.

1.4. Examples of Tasks for Processing Teaching Content

Search for information on the occurrence of chiral compounds in nature, their relationship with the metabolism of basic substances and their use in everyday life.

Make the other optical isomer of lactic acid following the same instructions.

Specify:

- a) compound name,
- b) molecular formula,
- c) create a complete and simplified molecular formula,
- d) optimize formula with *Clean Structure*,
- e) create a 3D model,
- f) create previews from different angles,
- g) determine the bond length between the first and second carbon atoms,
- h) determine the bond angle between the first and second carbon atoms.

Search for information on proteinogenic amino acids.

1.5. Examples of Students Evaluation Tasks

Create the formulas of L and D serine and determine:

- a) compound name,
- b) molecular formula,
- c) create a complete and simplified molecular formula,

- d) optimize formula with *Clean Structure*,
- e) create a 3D model,
- f) create previews from different angles,
- h) determine the bond length between the first and second carbon atoms,
- g) determine the bond angle between the first and second carbon atoms.

ALCOHOLS

1.) ELABORATION OF THE UNIT TITLE

Teaching unit: Organic Compounds
Unit title: Alcohols
Estimated number of hours: 2

1.1. Theoretical introduction

Alcohols are hydroxyl aliphatic derivatives of organic compounds in which hydrocarbons are bonded with one or more hydroxyl groups.

Alcohols can be categorized according to different criteria:

- according to the type of radical to which the hydroxyl group is bonded, there are aliphatic alcohols, aromatic alcohols and phenols;
- according to the type of carbon atom to which the hydroxyl group is bonded, there are primary alcohols, secondary alcohols and tertiary alcohols;
- according to the number of hydroxyl groups in their structure, alcohols can be monohydroxy, dihydroxy, and trihydroxy.

The methods for obtaining them have been known since the ancient times through the process of fermentation from grape sugar as the oldest method for obtaining alcohols, and later with technological development and increasing application, they can be obtained by several different processes, among which the catalytic one is used for industrial production by hydration of alkenes, (and for obtaining) in laboratory conditions with nucleophilic substitution and other methods.

The general formula of alcohols is R-OH or Ar-CH₂-OH where any aliphatic radical is attached to a hydroxyl group or an aromatic compound where the hydroxyl group is not directly attached to the aromatic ring, but to a side radical.

The hydroxyl group (-OH) is a functional group of alcohols and phenols.

The nomenclature of alcohols according to IUPAC is formed from the name (base) of the hydrocarbon by adding the suffix **-OL** or according to trivial names such as glycol, ethanol, glycerol, etc.

Alcohols are often named using the name of the radical in their structure and separately the word 'alcohol'. (There are also trivial names.) There is also a radical nomenclature according to which the name of the radical is read first, and then the hydroxyl group with the word 'alcohol'.

Because of their great variety and properties, alcohols are a big and very important group of compounds. The most known and important representatives from alcohols are methanol, ethanol, glycol and glycerol.

Name of alcohol	Methanol (Methyl alcohol)	Ethanol (Ethyl alcohol)	Propanol (Propyl alcohol)	Butanol (Butyl alcohol)	Ethane-1,2-diol (Glycol)	Propane-1,2,3-triol (Glycerol)	Benzyl Alcohol
molecular formulas	CH_4O	$\text{C}_2\text{H}_6\text{O}$	$\text{C}_3\text{H}_8\text{O}$	$\text{C}_4\text{H}_{10}\text{O}$	$\text{C}_2\text{H}_6\text{O}_2$	$\text{C}_3\text{H}_8\text{O}_3$	$\text{C}_7\text{H}_8\text{O}$

1.2. Educational Outcomes



In this chapter, students will learn:



- to draw different examples of alcohol molecules and present them with a structural, condensed structural formula and with skeletal formula.
- to generate name of previously drawn alcohol molecules in the *ChemSketch* program
- to determine the molecular formula of previously drawn alcohol molecules in the *ChemSketch* program
- to optimize the representation of the structure of molecules (adjustment of bond length and interbond angles) using the *Clean Structure* option
- to draw structural isomers of alcohol
- to show the structures of alcohol in three dimensions
- to rotate alcohol molecules in two and three dimensions
- to change the way of displaying the structures of molecules in three dimensions
- to move alcohol molecules in 3D and 2D
- to optimize the structures of alcohol molecules
- to save on the computer the two-dimensional and three-dimensional structure of the desired alcohol molecule

1.3. Instructions for Using the *ChemSketch* Program

Drawing different types of alcohols:

Example 1. Drawing monohydroxy, dihydroxy and trihydroxy alcohols using the *Draw Normal* tool.

STEP 1 Drawing monohydroxy, dihydroxy and trihydroxy alcohols can be done by using the button  from the *Atom* toolbar. On the *Structure* toolbar, click *Draw Normal* . In order to start drawing, you need to click on the working space whereby CH₄ will appear. With a left click on the CH₄ and dragging to the right, you will form a chain of two carbon atoms CH₃ – CH₃. In order to draw an alcohol, we need the -OH group which is added by the Oxygen key  from the atom toolbar. Using the same technique, click with a left click on the right CH₃ and drag to the right to add the hydroxyl group Creating -OH group. (**Figure 1**).

To draw the correct alcohol structure, select the whole structure by clicking the icon  and dragging around the whole structure. Then click *Tools* and choose the option *Clean Structure* .

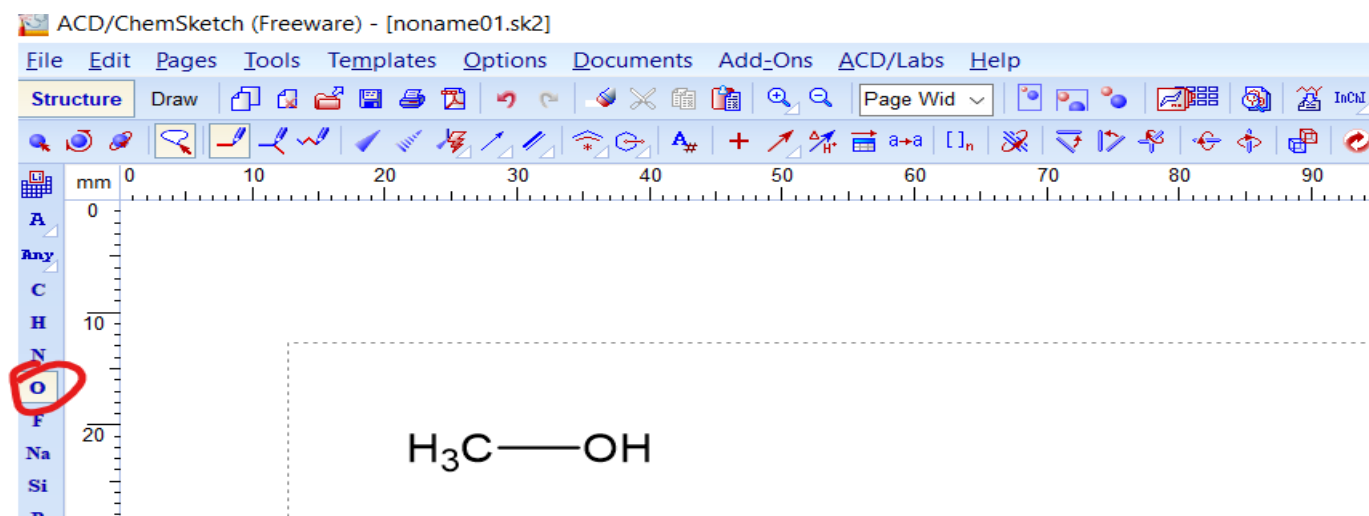
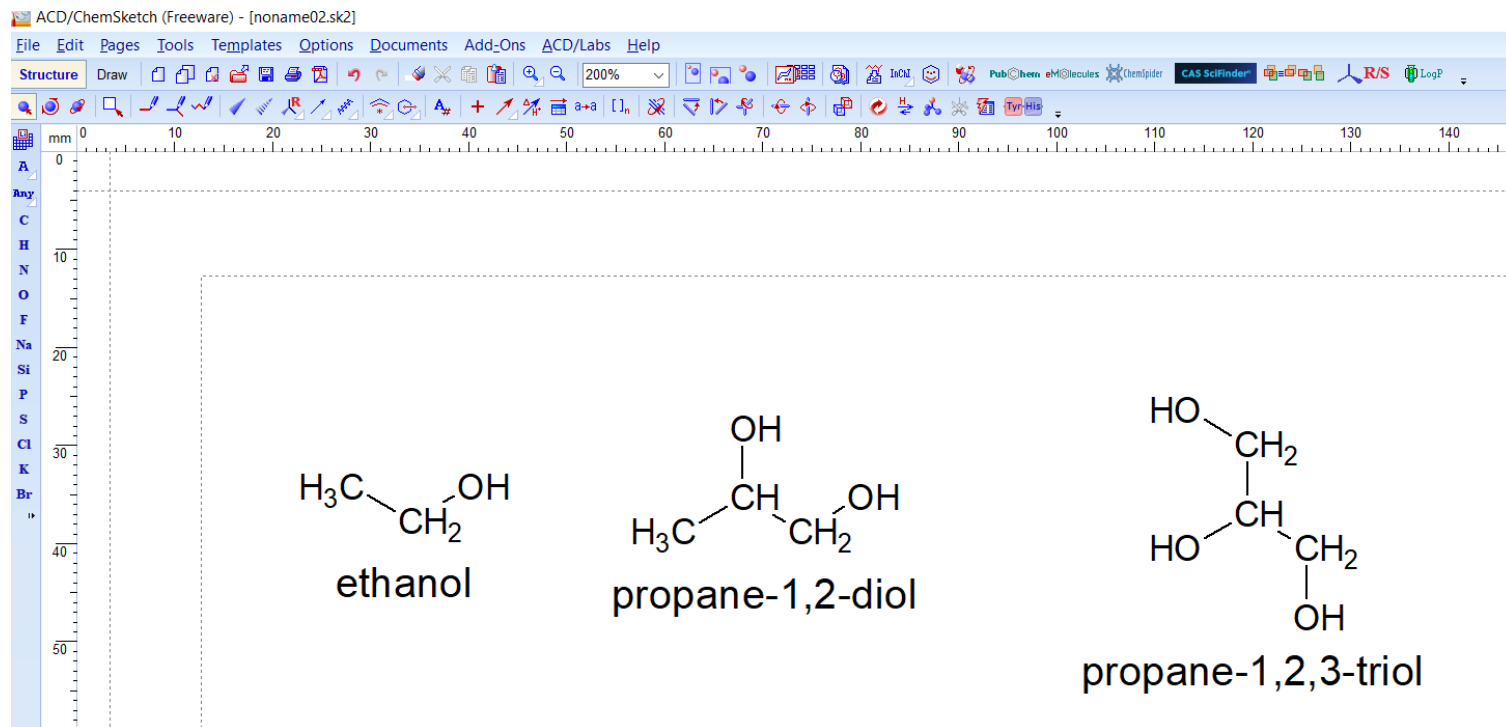

Figure 1. Structure of methanol (methyl alcohol)

STEP 2 Draw the structures of the ethanol, propane-1,2-diol, and propane-1,2,3-triol molecules as described in **STEP 1**. In each structure, all carbon atoms need to be shown (*Tools* → *Properties structure* → *Select All* → *Apply in the Show Carbon section*) and use the *Clean Structure* option. Finally, *Generate the names* of all three drawn molecule structures by choosing *Tools* and then *Generate Structure Name*. If you perform all the steps correctly, you should get the structures of the molecules and their associated names shown in **(Figure 2)**



(Figure 2)- Structure of monohydroxyl, dihydroxyl and trihydroxyl alcohols

Figure 2. Structures of ethanol, propane-1,2-diol and propane-1,2,3-triol molecules and their names.

STEP 3 To number the carbon atoms in the hydrocarbon sequence, it is necessary to highlight the entire alcohol structure and then select the *Manual Numbering* icon (**Figure 3a**) to open the *Manual Numbering* window and select *OK*. Clicking on the corresponding carbon atom brings up the number 1, and clicking on the second carbon atom brings up the number 2.

Note: The numbering of the hydrocarbon chain starts from the carbon atom closest to the hydroxyl group. (**Figure 3b**).

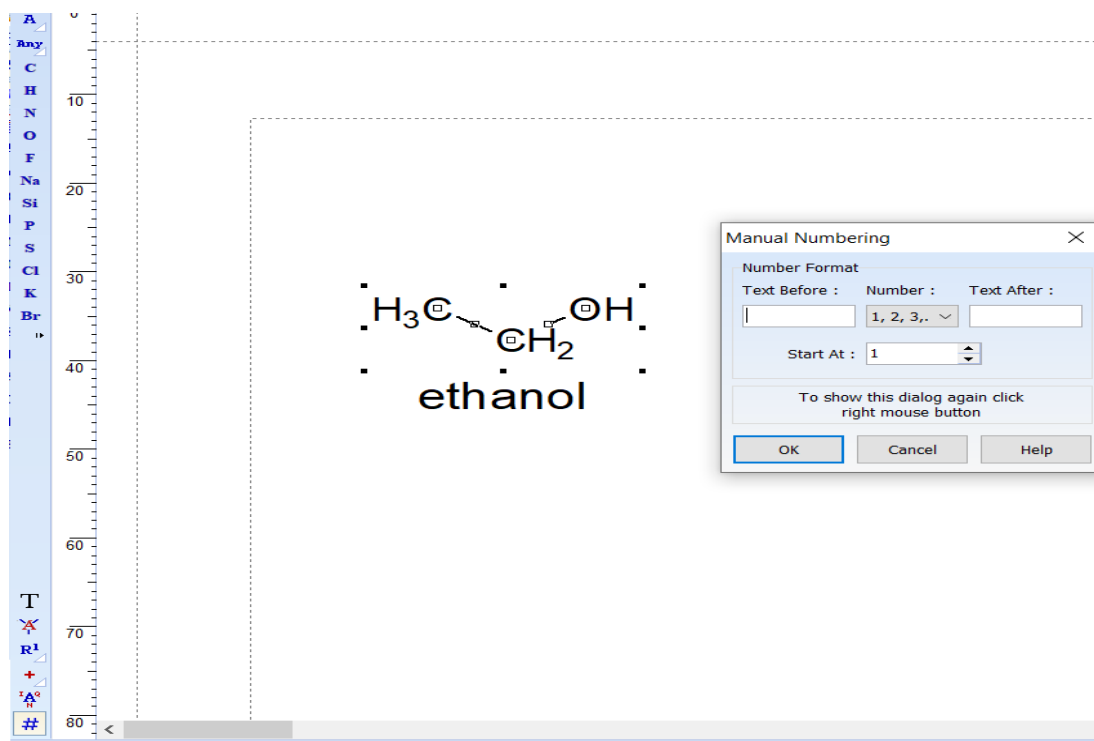

a)

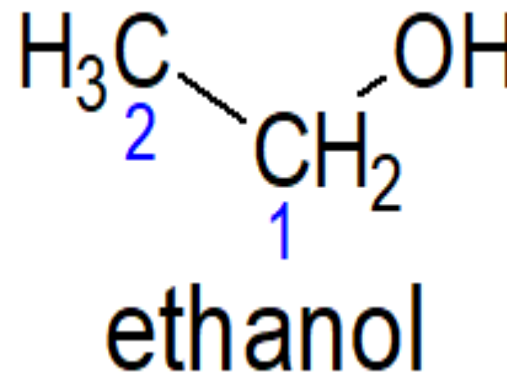

b)

Figure 3. a) Procedure for numbering carbon atoms in ethanol b) Numbered carbon atoms in the structure of the ethanol molecule

STEP 4 Repeat the procedure described in **STEP 3** using the example structures of propane-1,2-diol and propane-1,2,3-triol molecules (**Figure 4**).

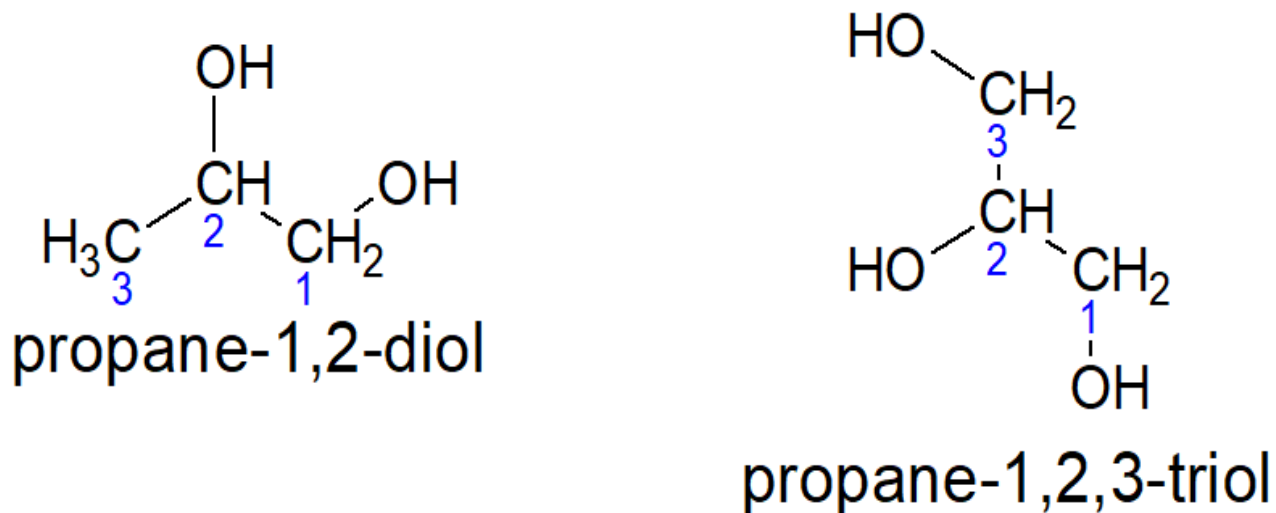
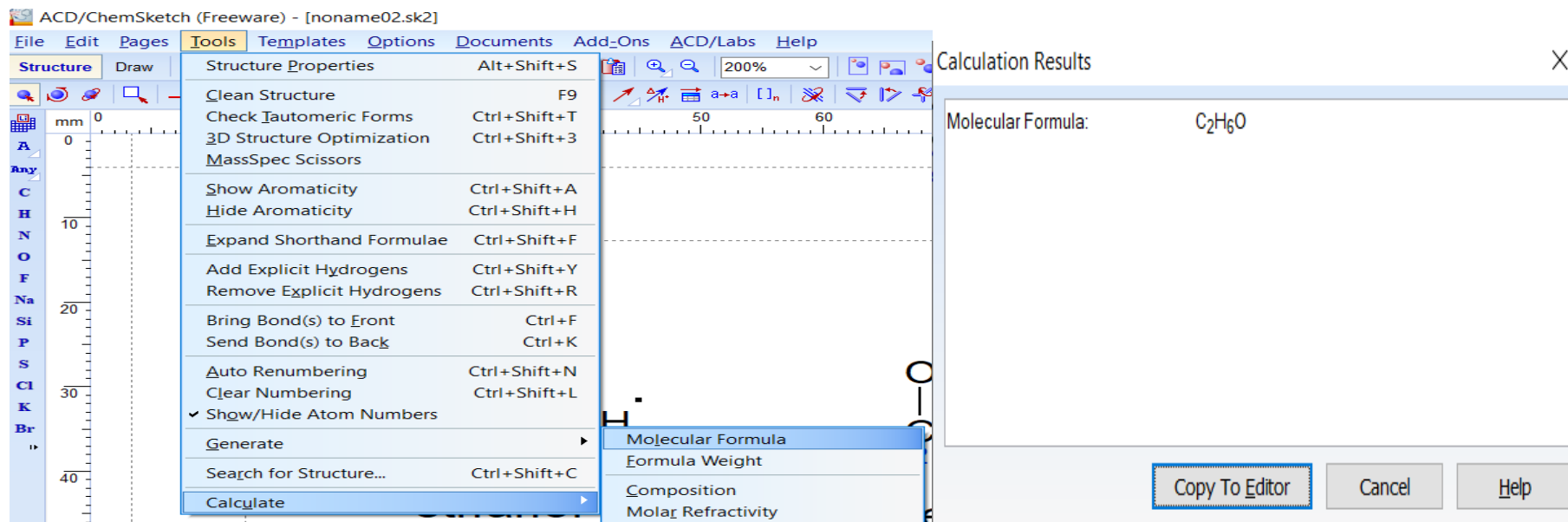

Figure 4. Numbering of carbon atoms in the structures of propane-1,2-diol and propane-1,2,3-triol molecules

STEP 5

The molecular formula of the drawn structures is determined by selecting *Tools*, then *Calculate* and *Molecular Formula*. The Calculation Results window appears with the molecular formula of the selected molecule structure (**Figure 5a and 5b**). In order for the molecular formula to appear on the workspace (**Figure 6**), it is necessary to select *Copy to editor*.



a)

b)

Figure 5. a) Sequence of actions to display the molecular formula of ethanol b) Window with the molecular formula of ethanol

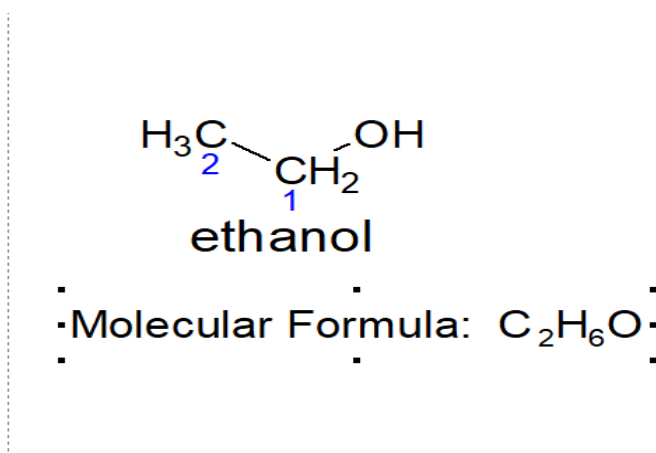



Figure 6. Molecular formula of ethanol

STEP 6 View the drawn alcohol structures in three dimensions by highlighting the structure of an alcohol molecule and then selecting the icon , after which a new window will appear with a 3D view of the molecular structure (**Figure 7**).

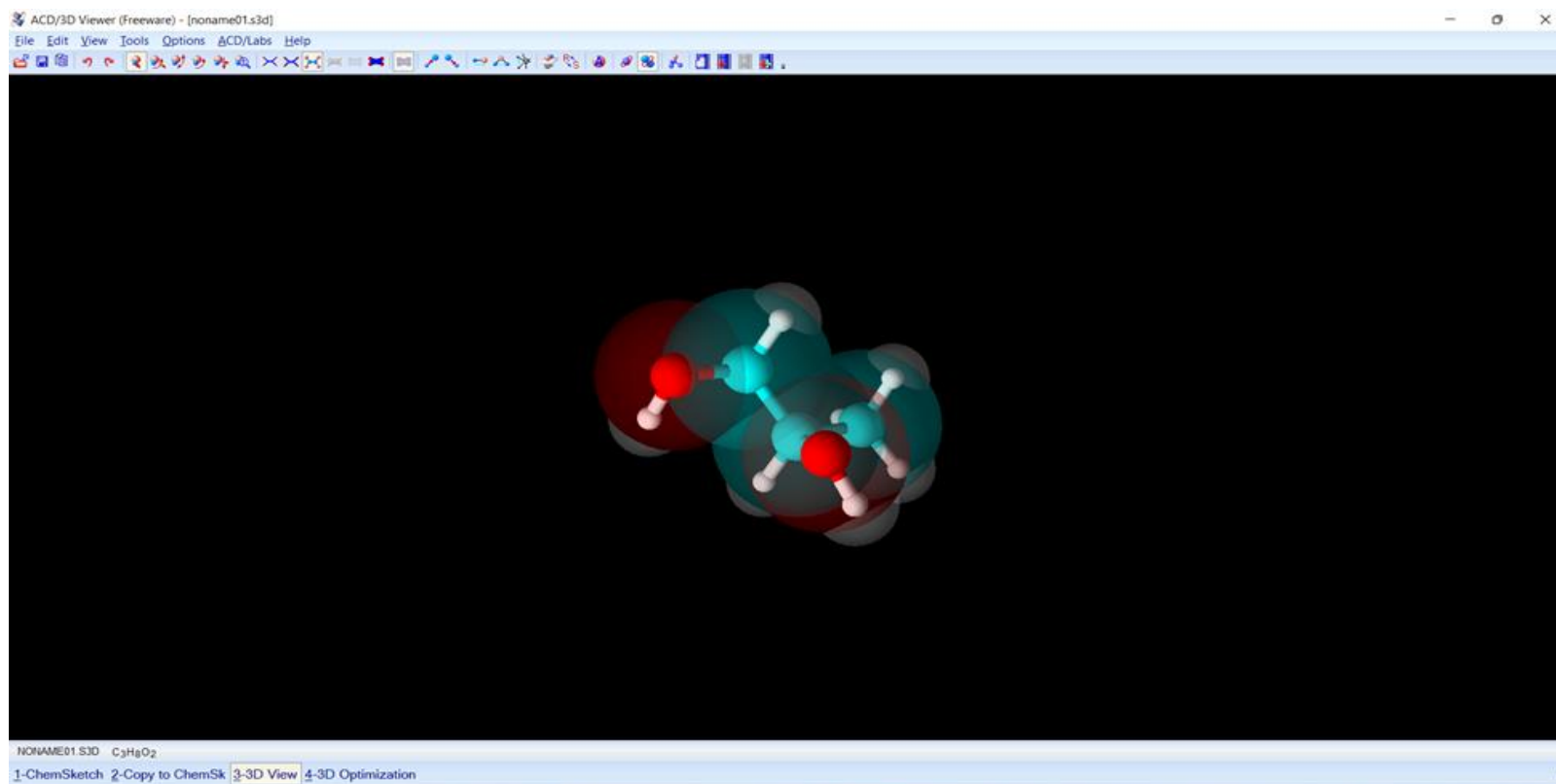

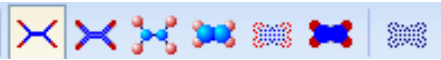



Figure 7 3D structure of the propane-1,2-diol

Try using each of the rotate, move, and select options on the top toolbar: , and then display the molecule in each of the ways the program offers, and the options are also displayed on the toolbar: .

Clicking on any of the options changes the way the propane-1,2-diol molecule is displayed. For automatic rotation of the molecule, click on the icon  .

For automatic continuous change from one to another molecule display mode with rotation, click on the icon  .

1.4. Examples of Tasks for Processing Teaching Content

1) Write the formula of hexan-2-ol alcohol. After it is drawn, perform the following steps:

- display all parts of the sequence, using the appropriate procedure, and not only the first and the last member,
- perform numbering of the sequence (it is necessary to pay attention from which side the numbering starts),
- name the alcohol,
- determine its molecular formula,
- make a 3D view,
- use the skills learned in *ChemSketch*, add another hydroxyl group to the third carbon atom in the structure of hexan-2-ol. Name the structure.
- add a double bond between the third and the fourth carbon atoms in the alcohol structure of hexan-2-ol. Name the structure.

2) Explore online the application of (methanol) methyl alcohol in everyday life. Draw the methanol molecule in the *ChemSketch* program. Write down in your notebook the application of the molecule, its positive and negative properties in everyday life. Draw a 3D representation of methanol (methyl alcohol) in

the *ChemSketch* program using the following tools  . Save the optimized 2D and 3D structure of these molecules to your computer.

1.5. Examples of Students Evaluation Tasks

Write the formula of hexan-2-ol alcohol, hex-5-en-3-ol. After it is drawn, perform the following steps:

- a) display all parts of the sequence using the appropriate procedure, and not only the first and the last member,
- b) perform numbering of the sequence (it is necessary to pay attention from which side the numbering starts),
- c) name the alcohol,
- d) determine its molecular formula.

ALDEHYDES AND KETONES

1.) ELABORATION OF THE UNIT TITLE

Teaching unit: Organic Oxygen Compounds
Unit title: Aldehydes and Ketones
Estimated number of hours: 2

1.1. Theoretical introduction

Aldehydes and ketones are organic compounds that have a carbonyl functional group (C=O). If the carbonyl group is situated at the end of the chain, the compound is an aldehyde and if it is situated in the middle of the chain, it is a ketone.

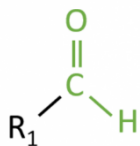

aldehyde

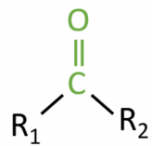

ketone

The oxygen atom in the carbonyl group is far more electronegative than the carbon atom. Thus, the carbonyl group is polar in nature.

The IUPAC system of nomenclature assigns the characteristic suffix *-al* to aldehydes. The *-e* is removed from the end of their parent alkane chain and is replaced with *-al*.

The characteristic suffix assigned to ketones is **-one**. The position of the carbonyl group is usually given by a location number.

The oxidation of primary alcohols produces aldehydes, and the oxidation of secondary alcohols produces ketones.

Aldehydes can be easily oxidized to form carboxylic acids. Ketones are very resistant to being oxidized.

Weak oxidizing agents like Fehling's and Tollen's reagents can be used to distinguish between an aldehyde and a ketone.

Aldehydes and ketones are used in the chemical industry as solvents, starting materials or reagents for other compounds. In nature, aldehydes and ketones are often combined with other functional groups, like in vanillin, hormones or carbohydrates. They are often used as essential oils.

1.2. Educational Outcomes

- to draw different examples of acyclic and cyclic aldehydes and ketones
- to show the structure of aldehydes and ketones with molecular, structural, condensed structural formulas and hyphens,
- to name aldehydes and ketones according to the IUPAC nomenclature or generate the name in the *ChemSketch* program,
- to determine the molecular formula of previously drawn aldehydes and ketones in the *ChemSketch* program
- to display 3D models of aldehyde and ketone molecules drawn in 2D using *ChemSketch* and rotate them,
- to improve the display of the structure of aldehydes and ketones using the *Clean Structure* function,
- to save the two-dimensional and three-dimensional structure of aldehydes and ketones on the computer,
- to improve digital skills by using a web browser to find other examples of aldehydes and ketones.

1.3. Instructions for Using the *ChemSketch* Program

Example 1

Methanal, ethanal, propanal, propan-2-one

Draw the methanal, ethanal, propanal and propan-2-one molecules to see the difference between aldehyde and ketone C=O group. Clean structure and generate names. Make 3D optimization and create 3D models. Rotate them.

STEP 1

Draw methane, ethane and twice the propane molecule as shown in **Figure 1**. Use *Structure mode* and *DrawNormal* option. Click on the empty area and CH₄ will appear. Clicking on the carbon atom creates a carbon-carbon single bond. By holding down the *Ctrl* key and clicking on each subsequent carbon atom, it is possible to draw the hydrocarbon chain of three carbon atoms.

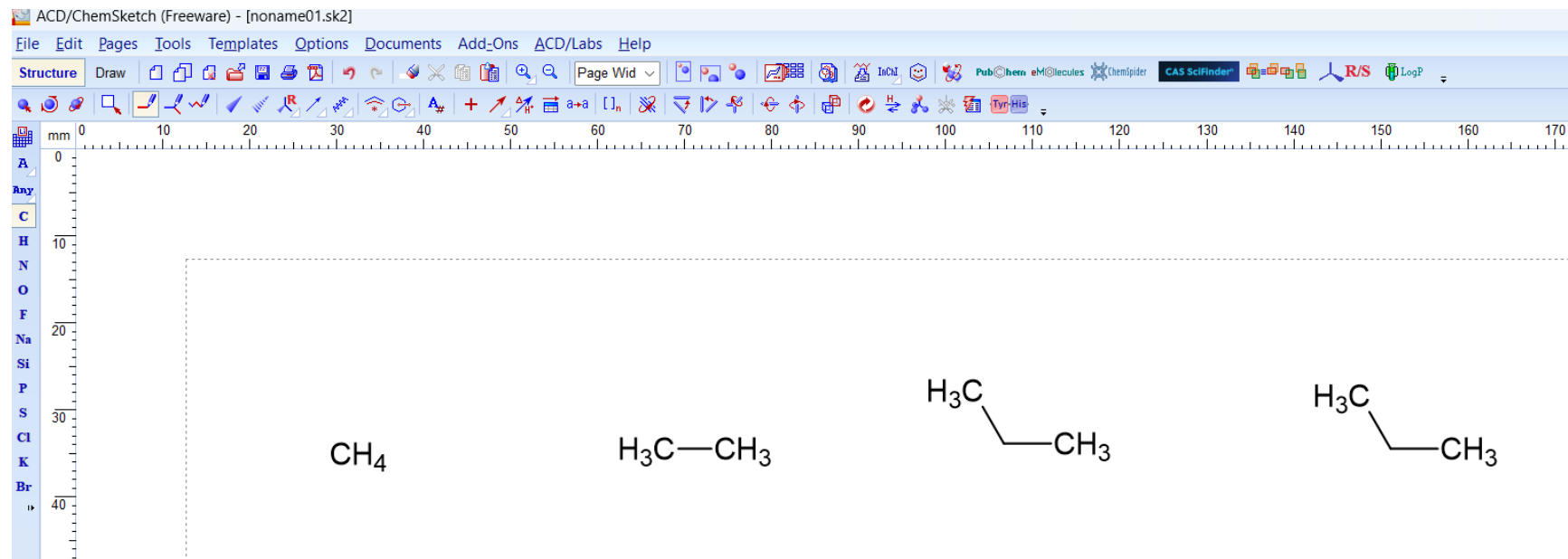
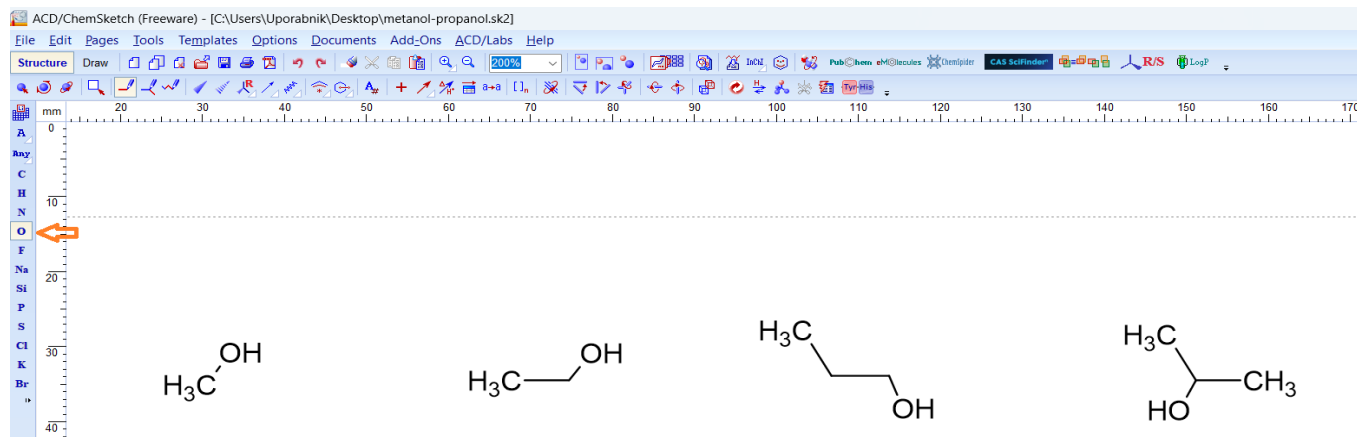

Figure 1. Methane, ethane, propane structure

STEP 2

Click on O (oxygen) on the left *Toolbar*. Click on the first C atom in methane, ethane and first propane and drag with the mouse. An OH group will appear (**Figure 2a**). Click on the second C atom in the second propane molecule and drag with the mouse to create OH group. Click on the C-OH bond in every structure. The C=O group will appear as shown in **Figure 2b**.



a

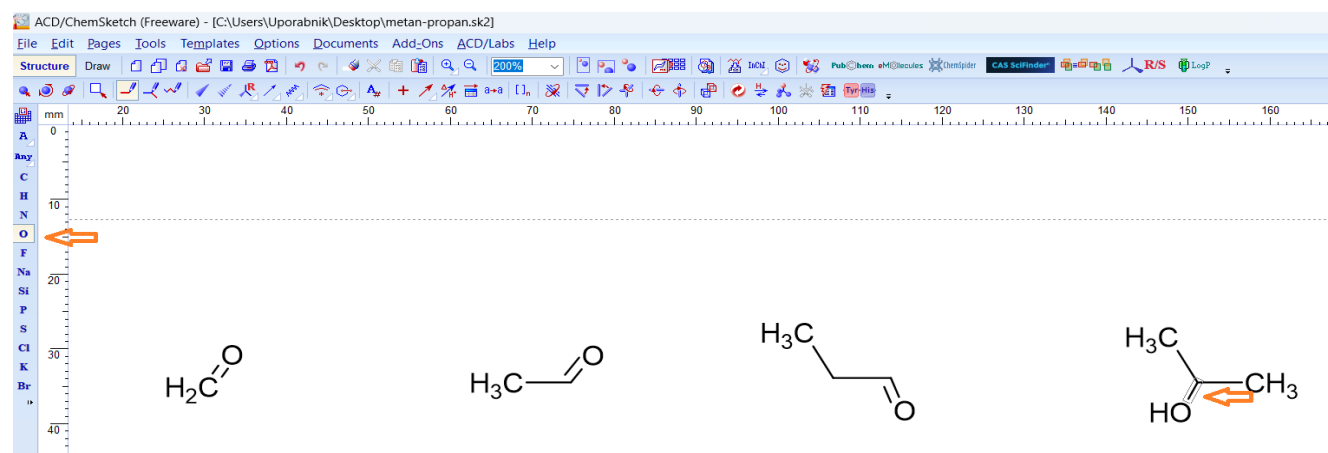

b

Figure 2. a) Creating C-OH bond, b) creating C=O bond.

STEP 3

Click on atom H on the left *Toolbar*, click on atom C of C=O group and drag with the mouse to create CHO group in the first three structures (**Figure 3**).

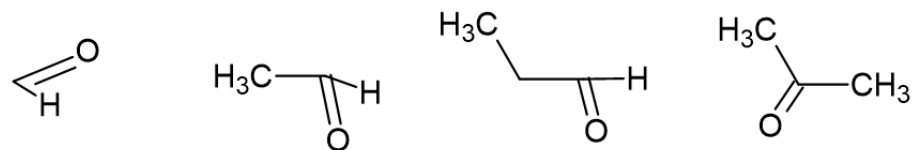
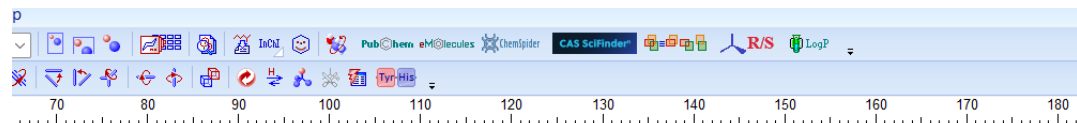
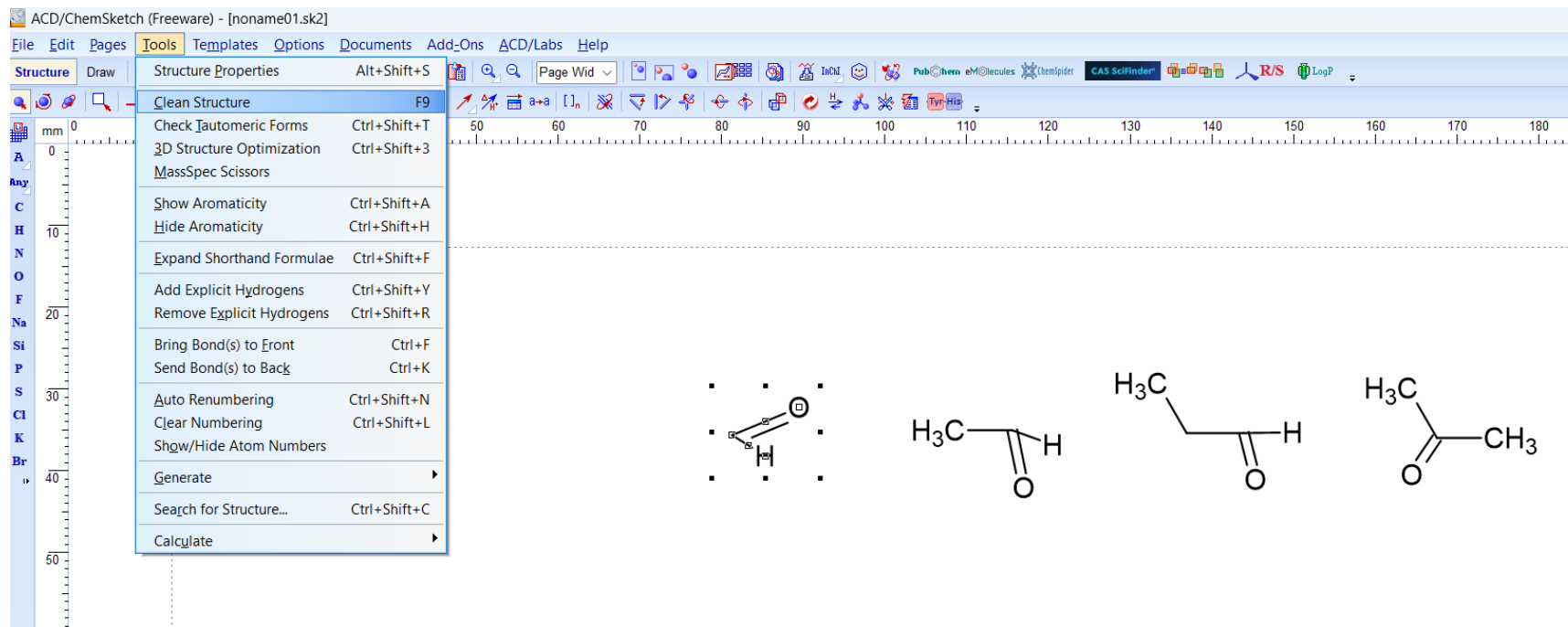

Figure 3. Creating a CHO group.

STEP 4

Select the first structure with *Lasso* and then use the *Tool* option and select *Clean Structure* (**Figure 4a**). Do the same with all structures to get structures in **Figure 4b**.



a

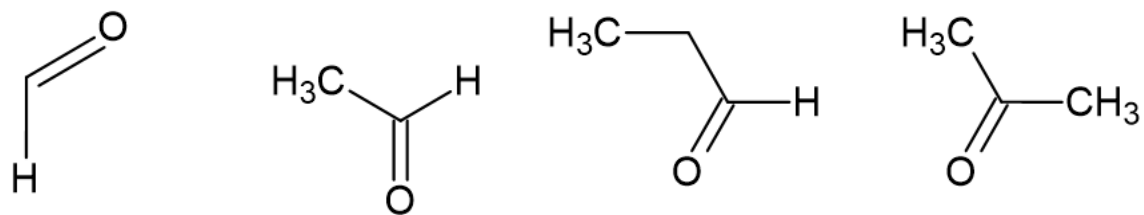

b

Figure 4. a) Cleaning Structures, b) Cleaned structures.

STEP 5

Use *Lasso* and select the first drawn structure. Click on the *Tools* menu, select *Generate* and then *Name for Structure* as shown in **Figure 5a**. Do the same with all structures to get their names (**Figure 5b**).

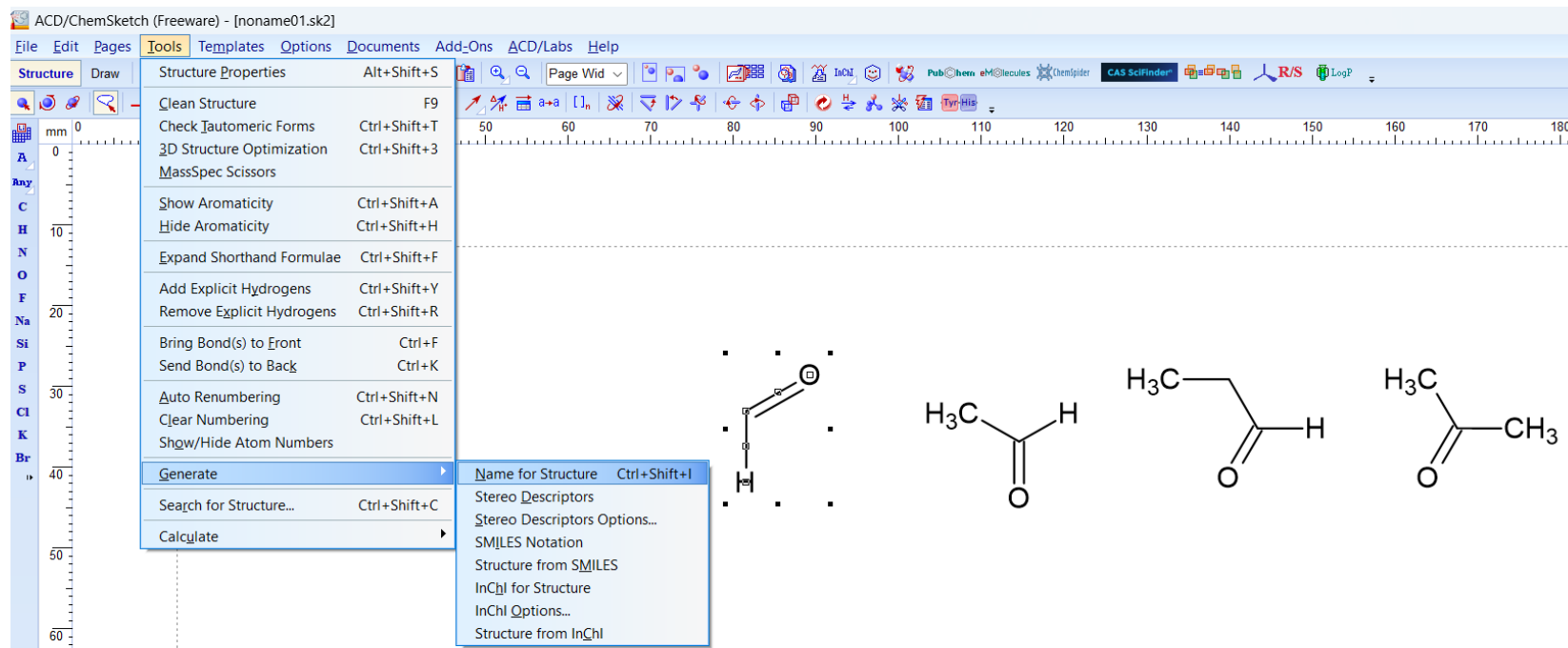

a

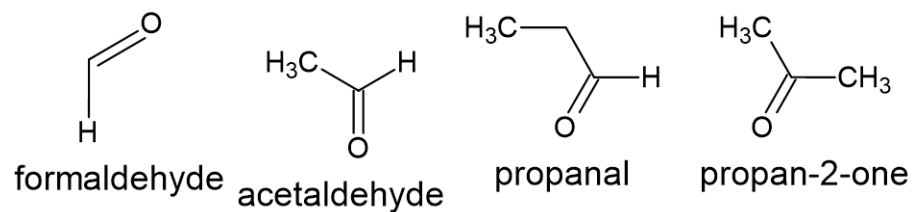

b

Figure 5. a) Naming structures, b) Named structures.

STEP 6

For 3D optimization select each of the drawn structures and use the 3D optimization icon as shown in **Figure 6a**. The window in **Figure 6b** will appear. Choose *No*. **Figure 6c** shows structures after 3D optimization.

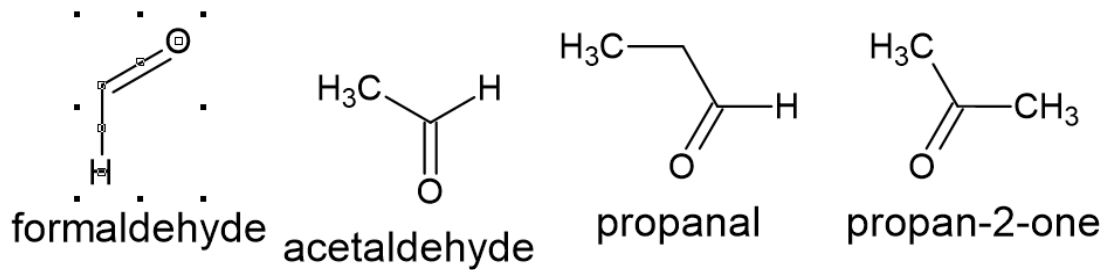
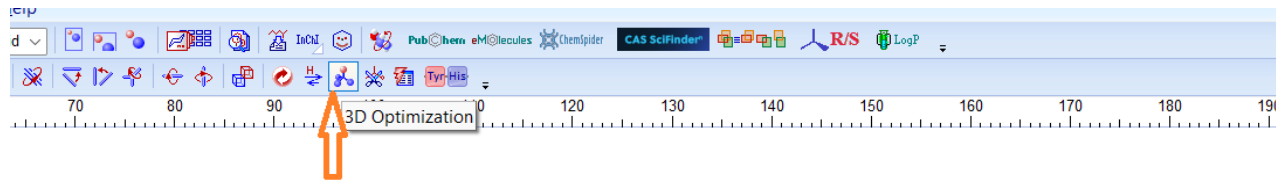

a

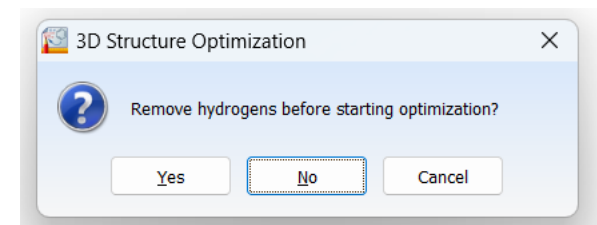

b

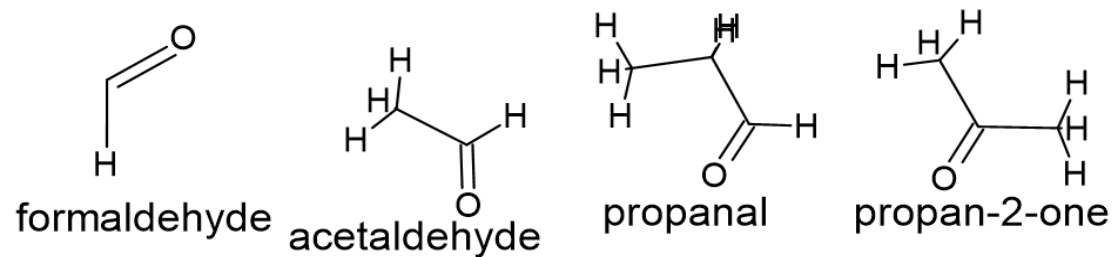

c

Figure 6. a) 3D optimization of the selected structure, b) The new window, c) 3D optimized structures of methanal, ethanal, propanal and propan-2-one

STEP 7

Select propanal and then propan-2-one. Use the *3D Viewer* button as shown in **Figure 7a**. A new window with a 3D view will appear. You can rotate the structure and change its look to see the difference between aldehyde and ketone carbonyl group.

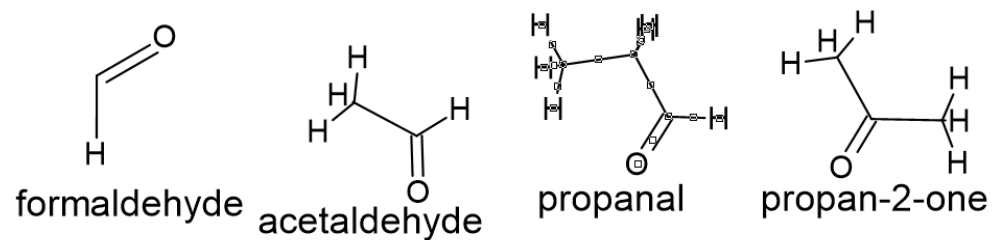
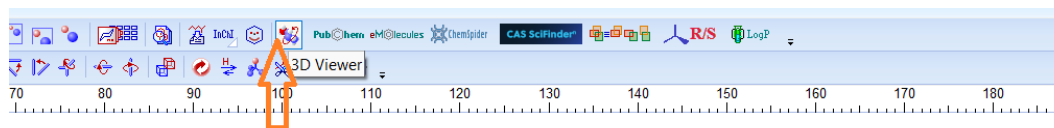

a

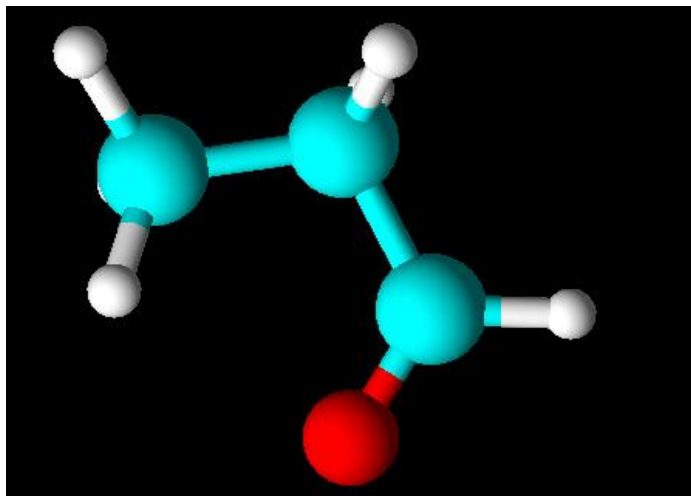

b

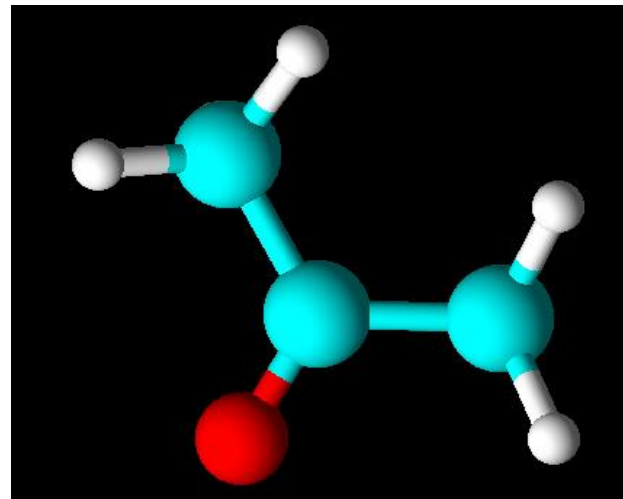

c

Figure 7. a) Creating a 3D Model, b) 3D Model of propanal molecule, c) 3D Model of propan-2-one molecule.

STEP 8

Save the structures and 3D models by clicking *File* and then *Save As*.

Example 2

Draw the phenyl ethanal molecule. Phenyl ethanal has a smell like lilac and hyacinth. Clean structure, create a name and molecular formula and display it in three dimensions.

STEP 1

On the right side toolbar (*Radicals Toolbar*) click on benzene and then click on an empty area. The structure of benzene will appear. Click on any carbon atom to create CH₃ group, click again to create ethyl group, the drawn structure is ethylbenzene as shown in **Figure 1**.

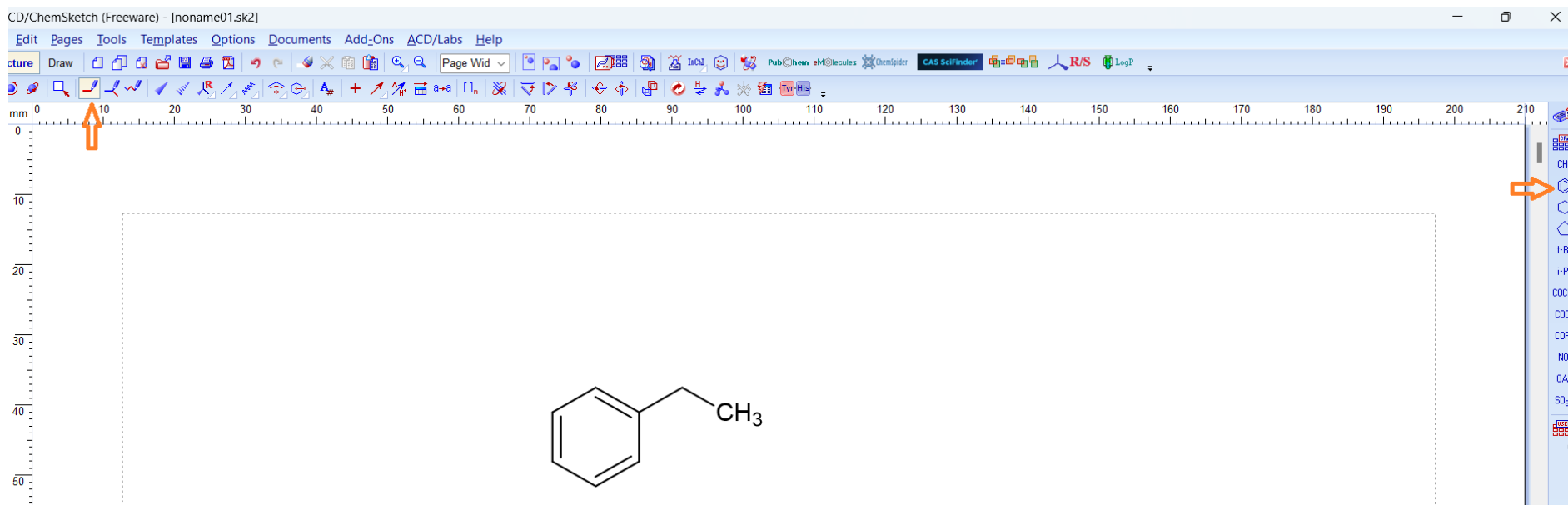



Figure 1. Ethylbenzene.

STEP 2

Select O on the left side toolbar. On the *Structure* toolbar, click *Draw Normal* () and then click the last carbon atom and add a bond. Click on the C-OH bond to get the carbonyl group like in **Figure 2**.

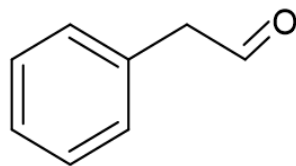

Figure 2. Created benzene with ethyl and carbonyl group.

STEP 3

Select the structure with *Lasso* and then use *Tool* option and select *Clean Structure* as shown in **Figure 3a** to get cleaned structure in **Figure 3b**.

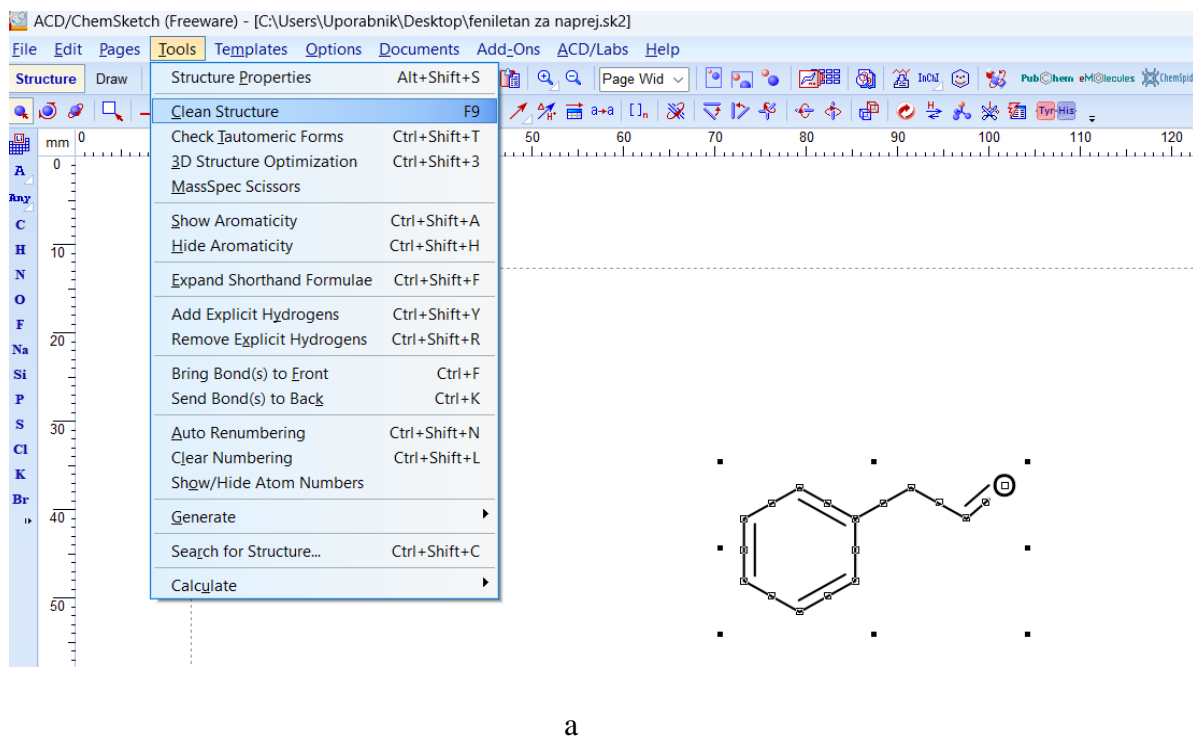
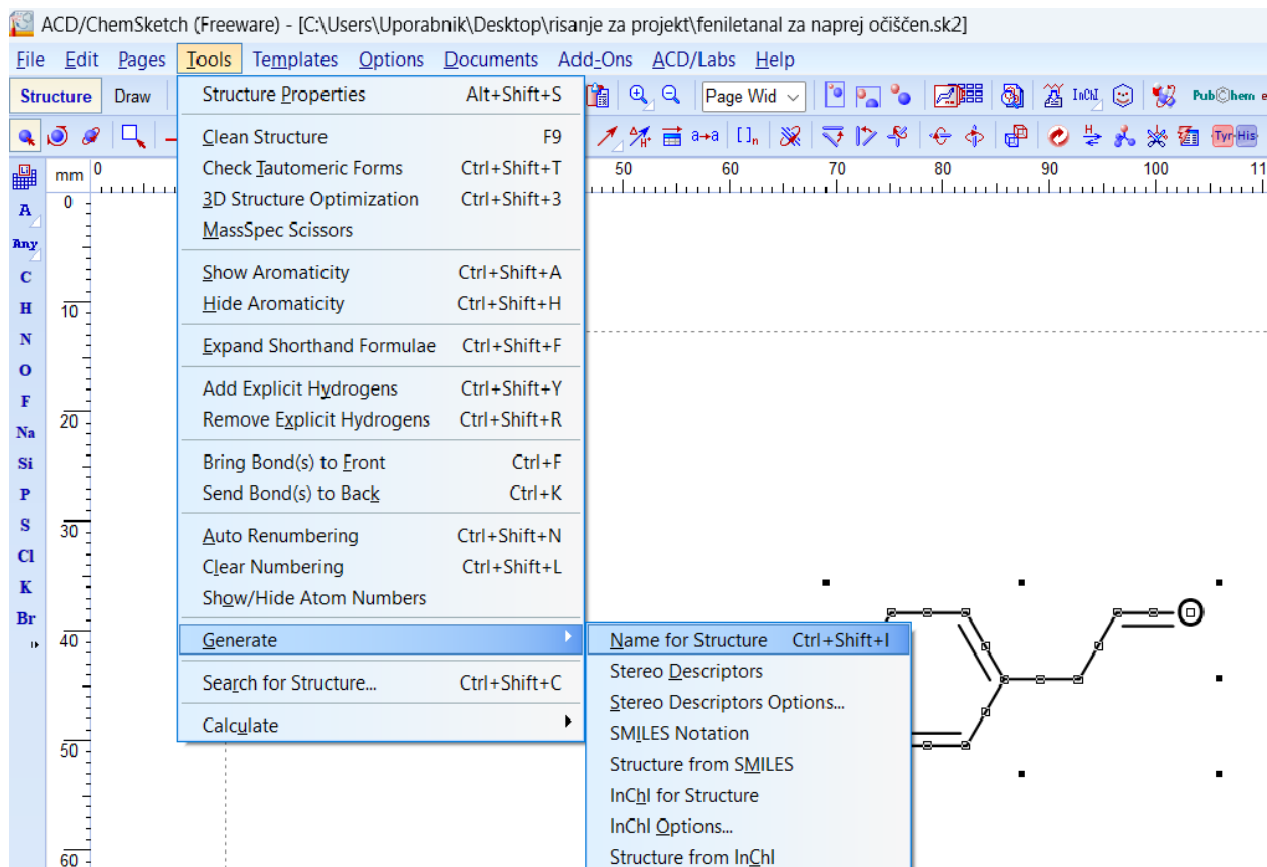

Figure 3. a) Cleaning structure, b) Cleaned structure.

STEP 4

Use *Lasso* and select the drawn structure. Click on the *Tools* menu, select *Generate* and then *Name for Structure* as shown in **Figures 4a** and **4b**.



a

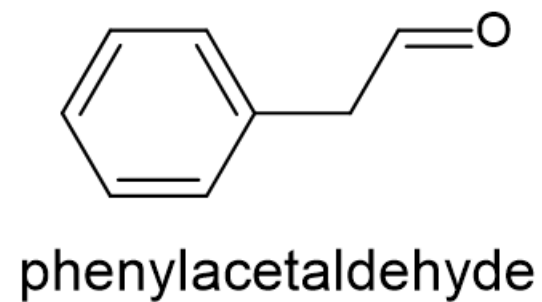

b

Figure 4. a) Creating the name for the drawn structure, b) Drawn and named structure.

STEP 5

Use *Lasso* and select the drawn structure. Click on the *Tools* menu, select *Calculate* option and then click on *Molecular Formula* (**Figure 5a**). A new window with a molecular formula will appear. Choose *Copy to Editor* (**Figure 5b**) to get the molecular formula as shown in **Figure 5c**.

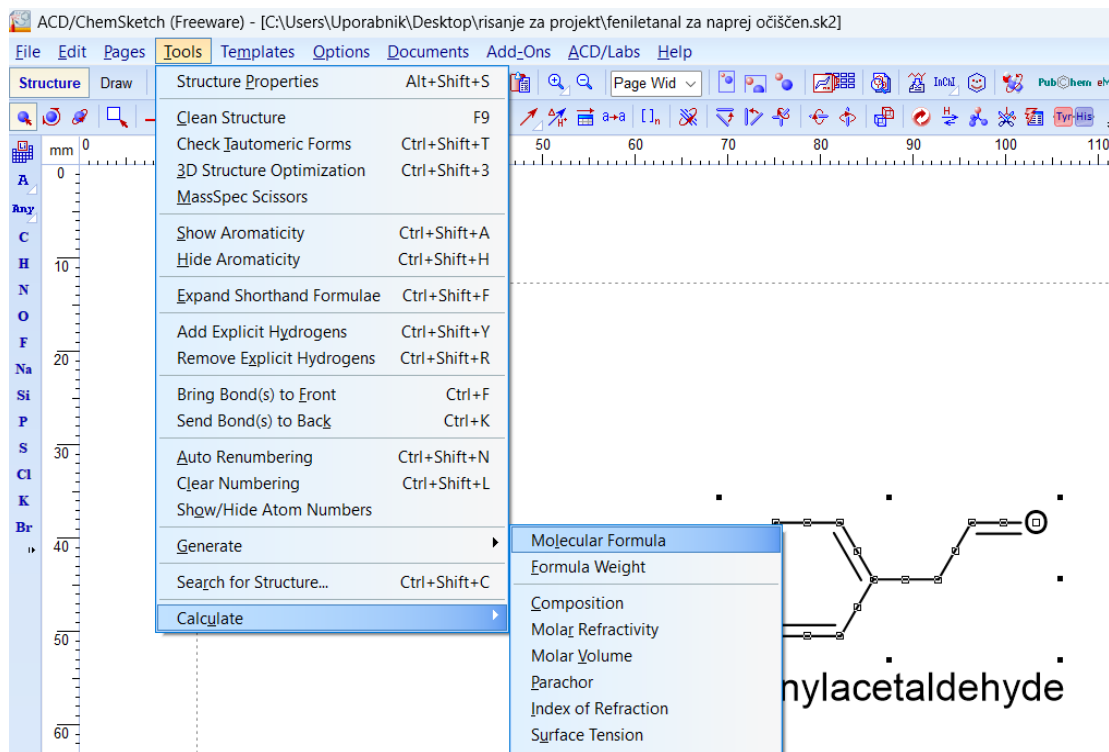

a

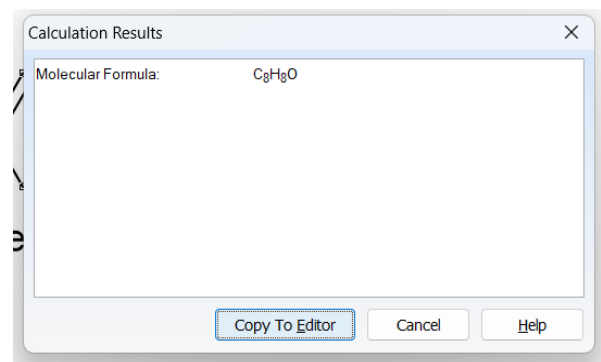

b

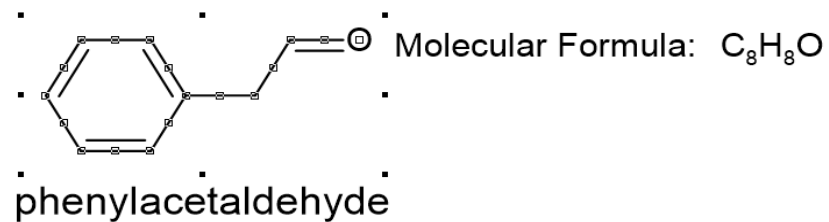

c

Figure 5. a) Creating molecular formula, b) Displaying molecular formula, c) Displaying molecular formula.

STEP 6

For 3D optimization select the drawn structure with *Lasso* and then click the 3D optimization icon like in Example 1. For moving the name and molecular formula use *Select/Move* button and just move the space with the name and formula as shown in **Figures 6a and 6b**.

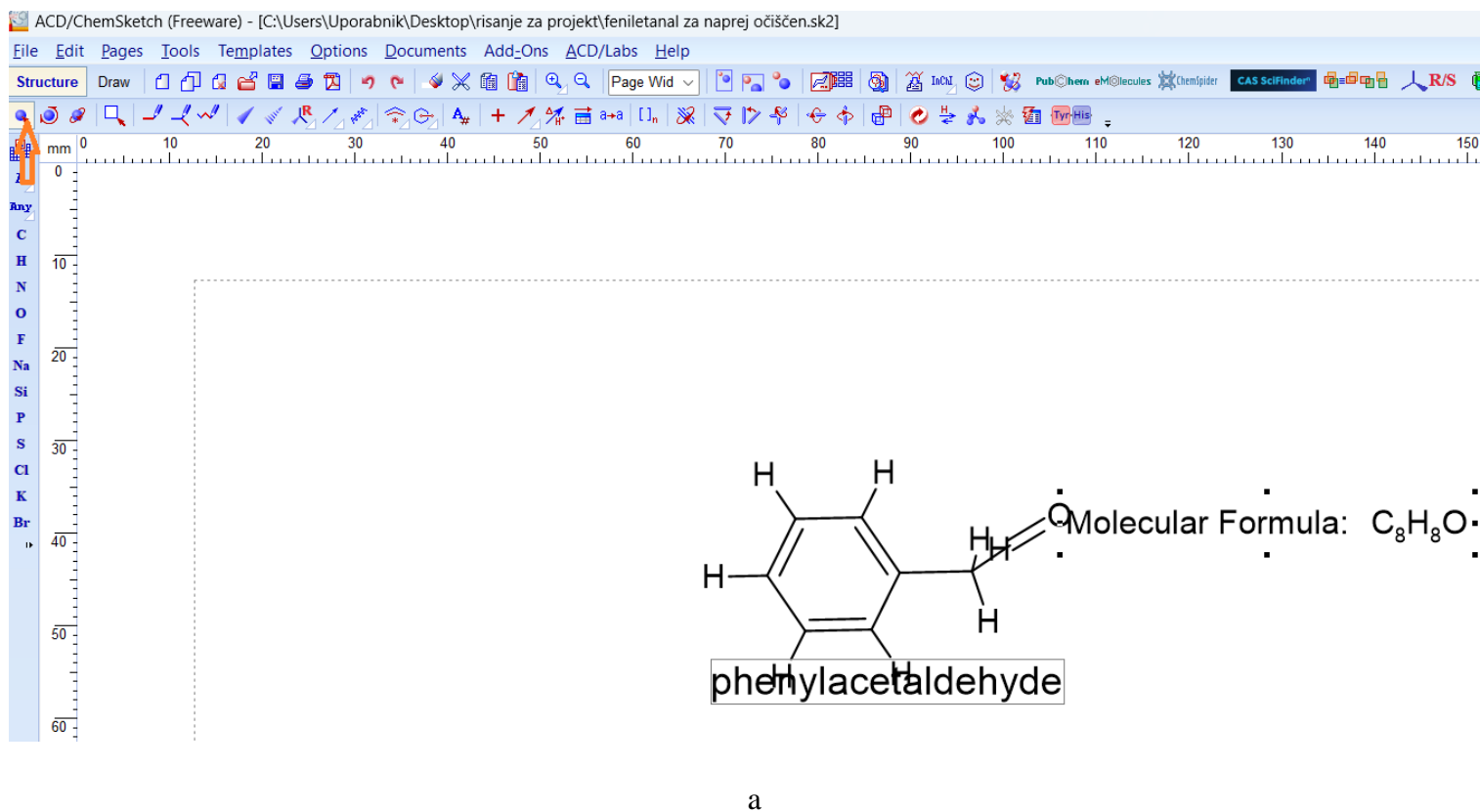
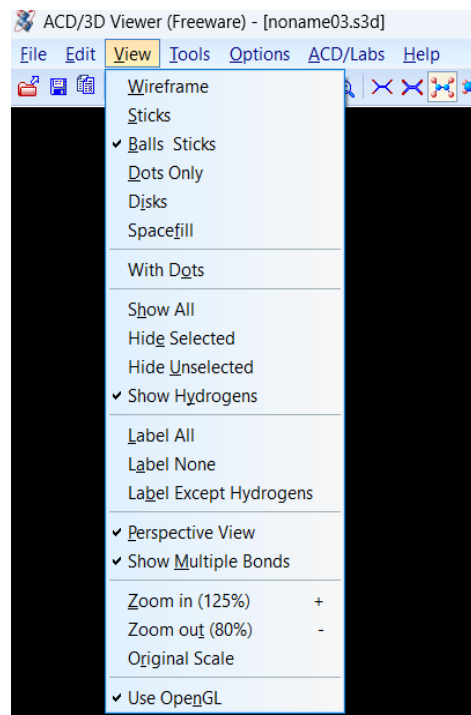

Figure 6. a) and b) Moving name and molecular formula from 3D optimized formula.

STEP 7

Transfer the structure to *3D Viewer*. Rotate the structure and use different ways of displaying phenyl ethanal molecule. Some of them are shown in **Figures 7a-7e**.



a

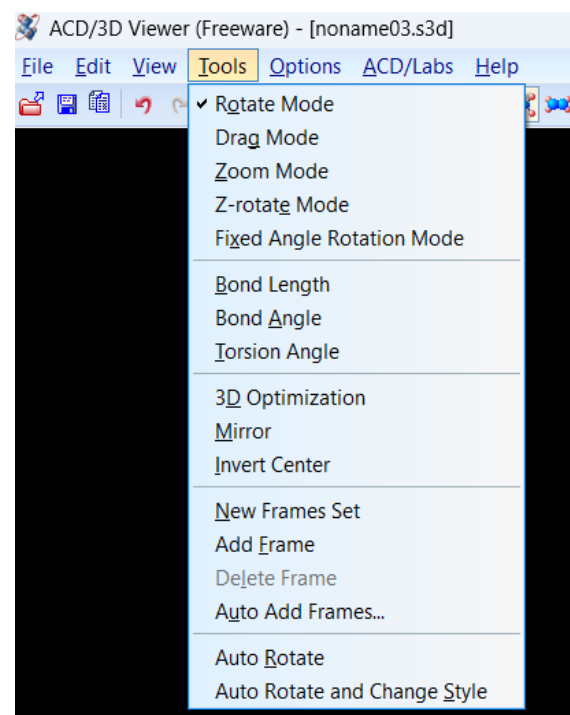

b

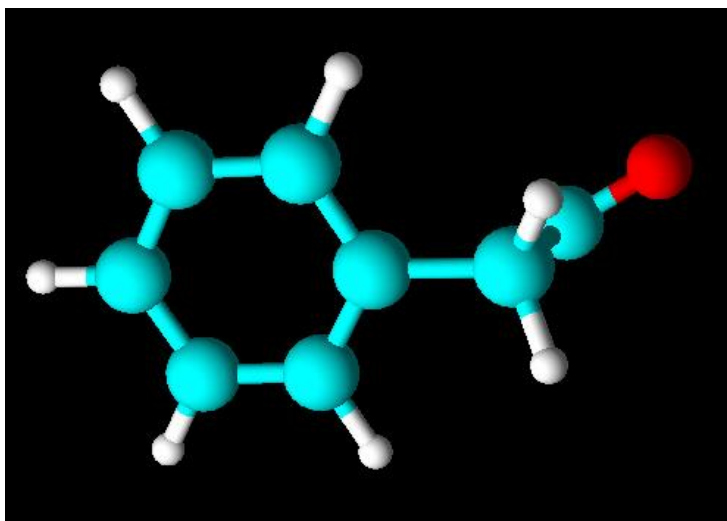

c

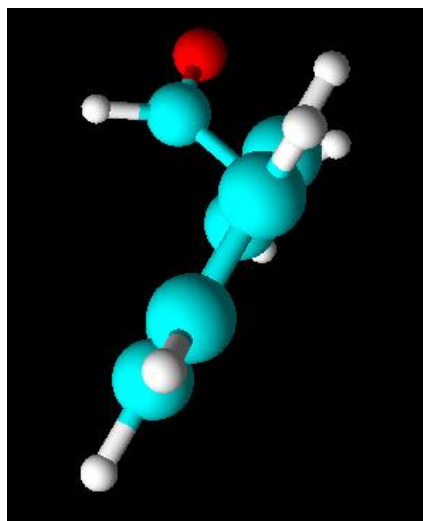

d

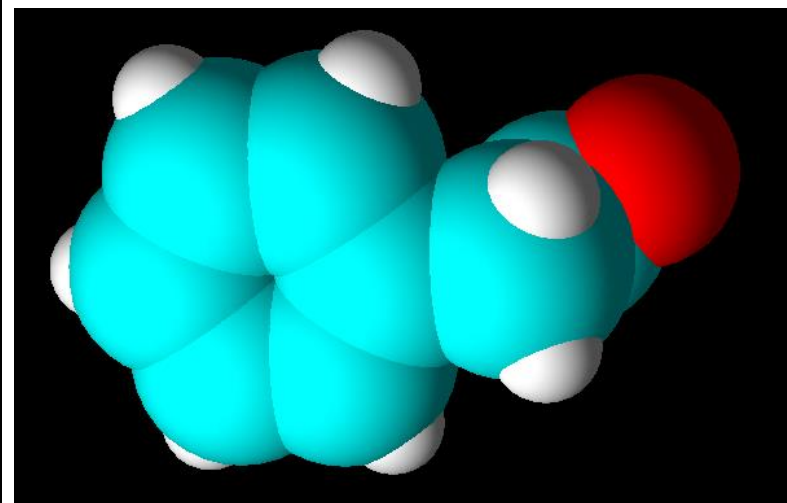

e

Figure 7. a-e) Different ways of displaying models of phenyl ethanol.

STEP 8

Save the structures and 3D models by clicking *File* and then *Save As*.

Example 3

Draw the cyclopentane-1,3-dione molecule. Display it with skeletal, structural and molecular formula.

STEP 1

On the right side toolbar (*Radicals Toolbar*) click on cyclopentane and then click on an empty area. The structure of cyclopentane will appear as shown in **Figure 1**.

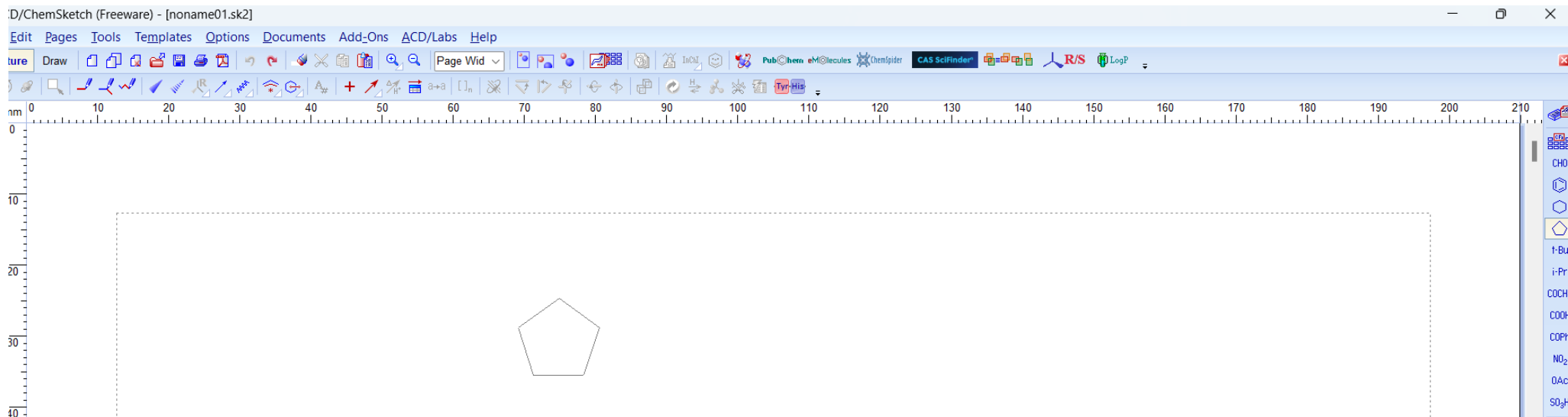
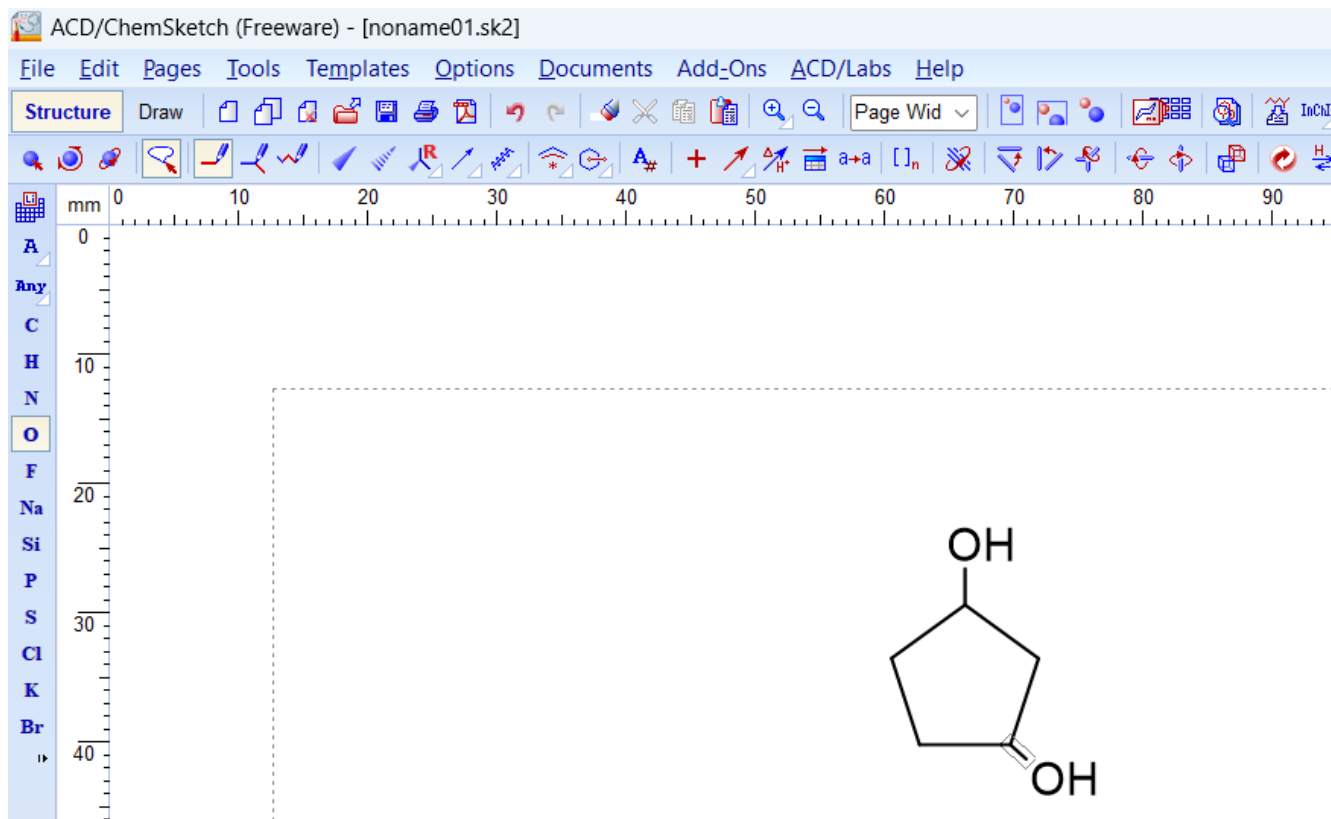

Figure 1: cyclopentane

STEP 2

Select O on the left toolbar and create a bond on any carbon atom and do the same on the third carbon atom, use a mouse (**Figure 2a**). Click on C-OH bonds to get the carbonyl group (**Figure 2b**).



a

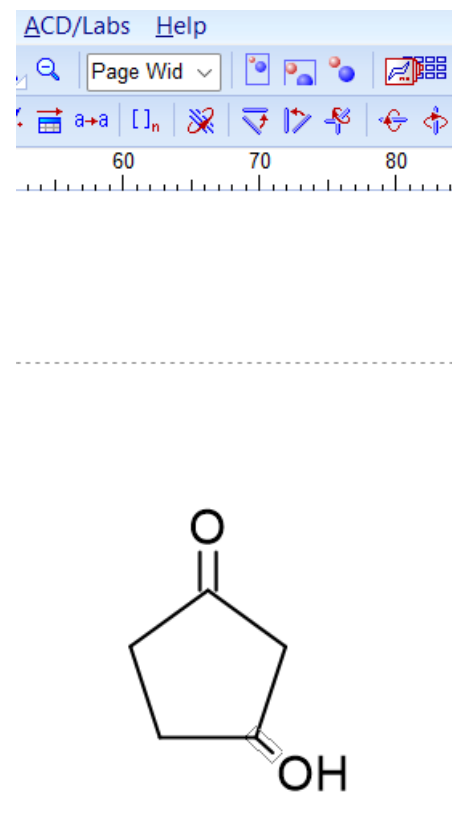

b

Figure 2. a) creating C-OH bond, b) creating C=O bond.

STEP 3

Clean structure by selecting a structure with *Lasso* and clicking *Tools, Clean Structure* option (**Figure 3a**) or using the *Clean Structure* icon. The skeletal formula of cyclopentane-1,3-dione will appear as shown in **Figure 3b**.

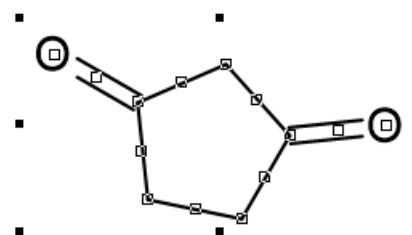
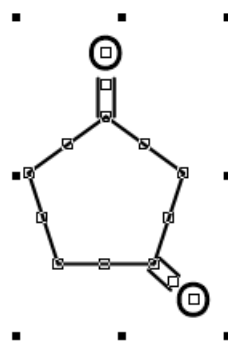
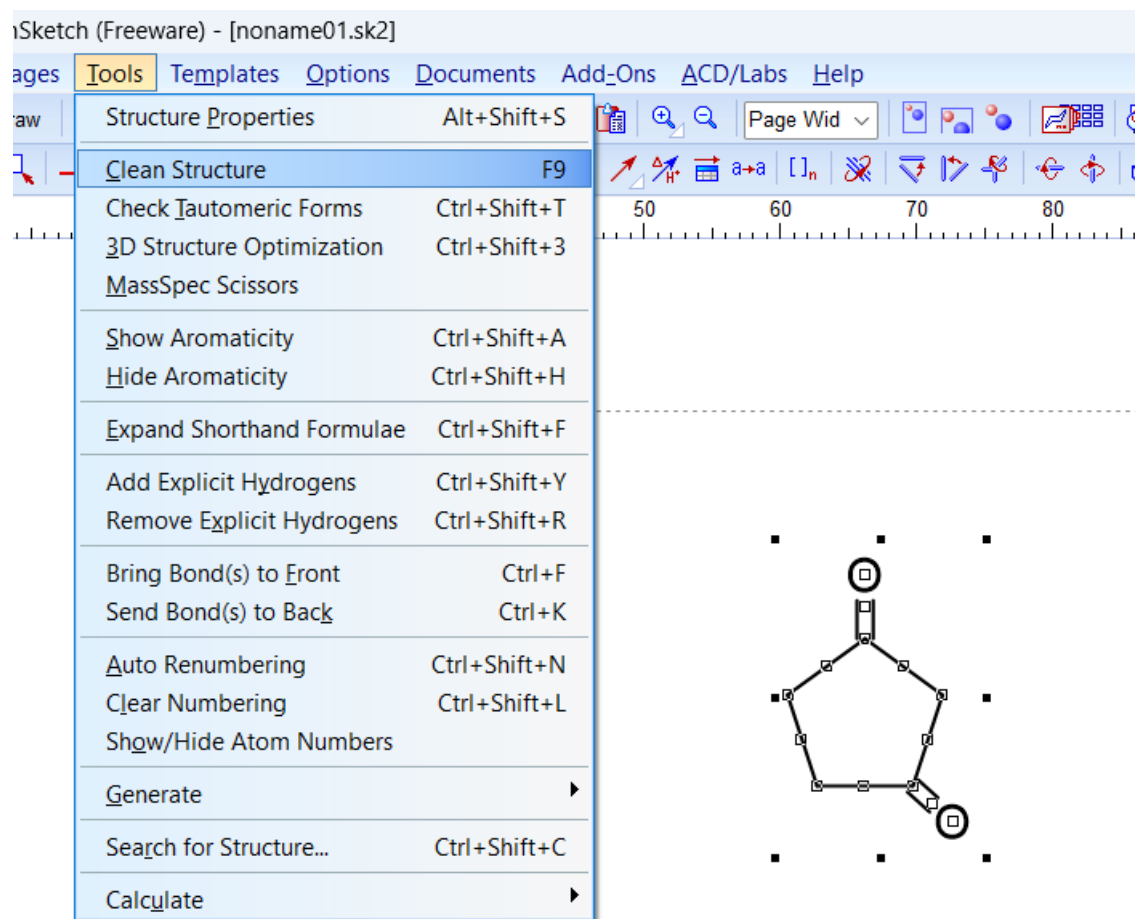

a

b

Figure 3. a) Cleaning structure of cyclopentane-1,3-dione, b) Cleaned structure of cyclopentane-1,3-dione.

STEP 4

To display the drawn skeletal formula with structural formula, click on *Tools* and select *Add Explicit Hydrogens* option (**Figures 4a and 4b**). Select the structure with *Lasso*, click on *Tools* and then *Structure Properties* (**Figure 4c**). A new window will appear. Select *All* in the *Show Carbons* part, and then click *Apply* as shown in **Figure 4d** to get the structural formula (**Figure 4e**).

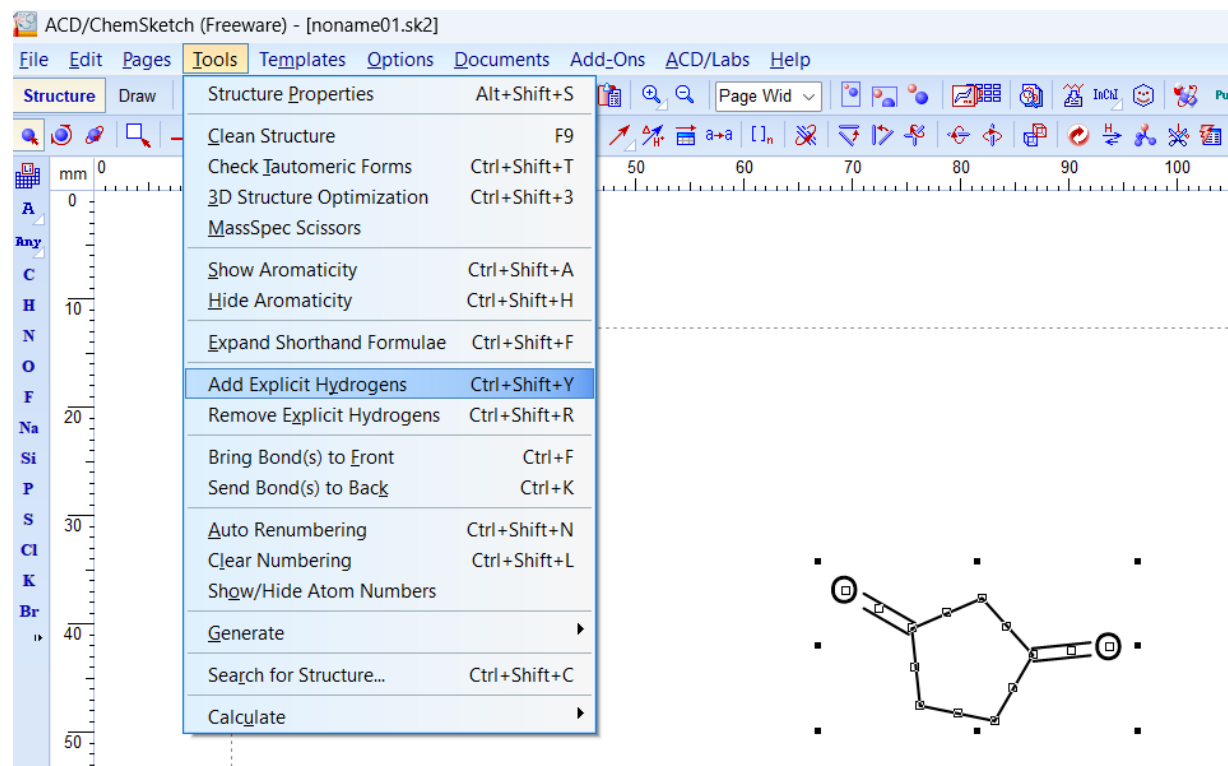

a

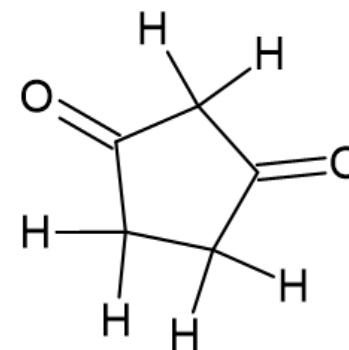

b

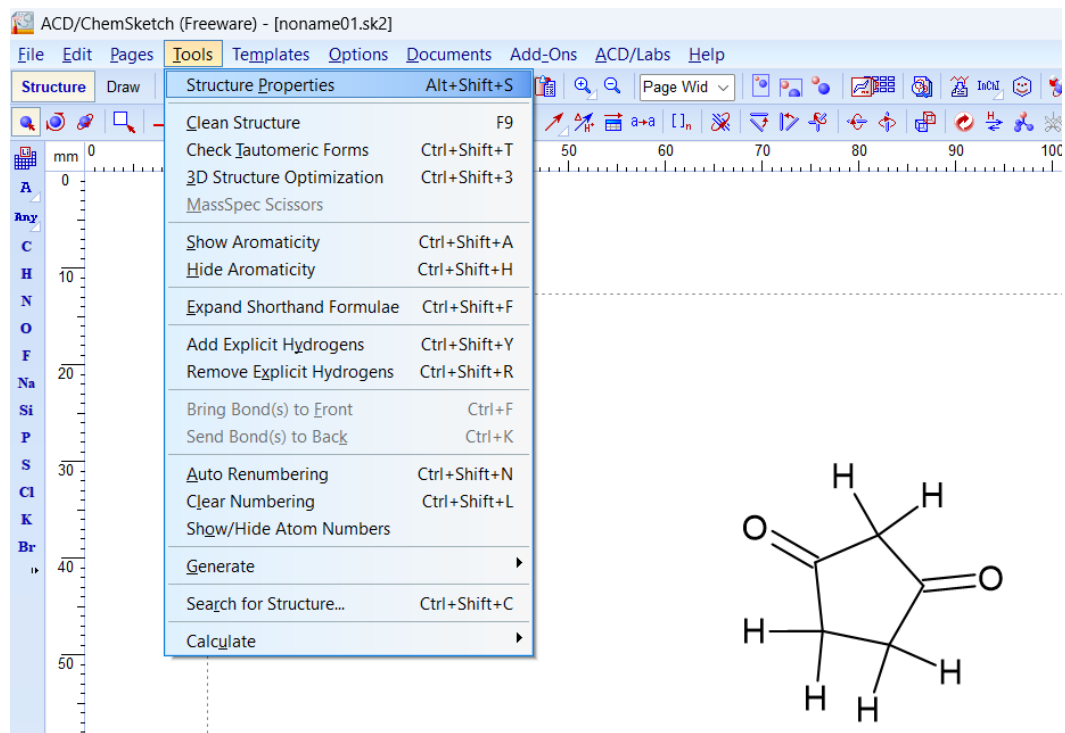

c

Properties ? X

Current Style

AUTOSAVE Save Del

Markush Biosequence Coloration

Common Atom Bond

Show Carbons

- All
- Hide Zero Charge
- Terminal
- Cross Out Invalid Atom

Size Calculation

Atom Symbol Size 10

- Auto
- Bond Length 7 mm

Atom Style Bond Style

Arial 0.7 pt

B

Apply Set Default

Update From Restore Default

d

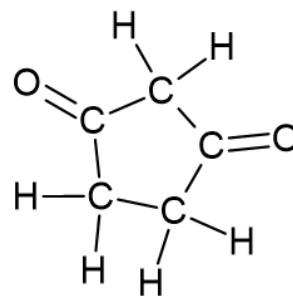

e

Figure 4. a) Adding explicit hydrogens, b) Explicit hydrogens are added, c) Changing structure properties, d) Showing carbons to create structural formula, e) The structural formula of pentane-1,3-dione

STEP 5

Create molecular formula using *Tools*, *Calculate* and then *Molecular formula* as in Example 2.

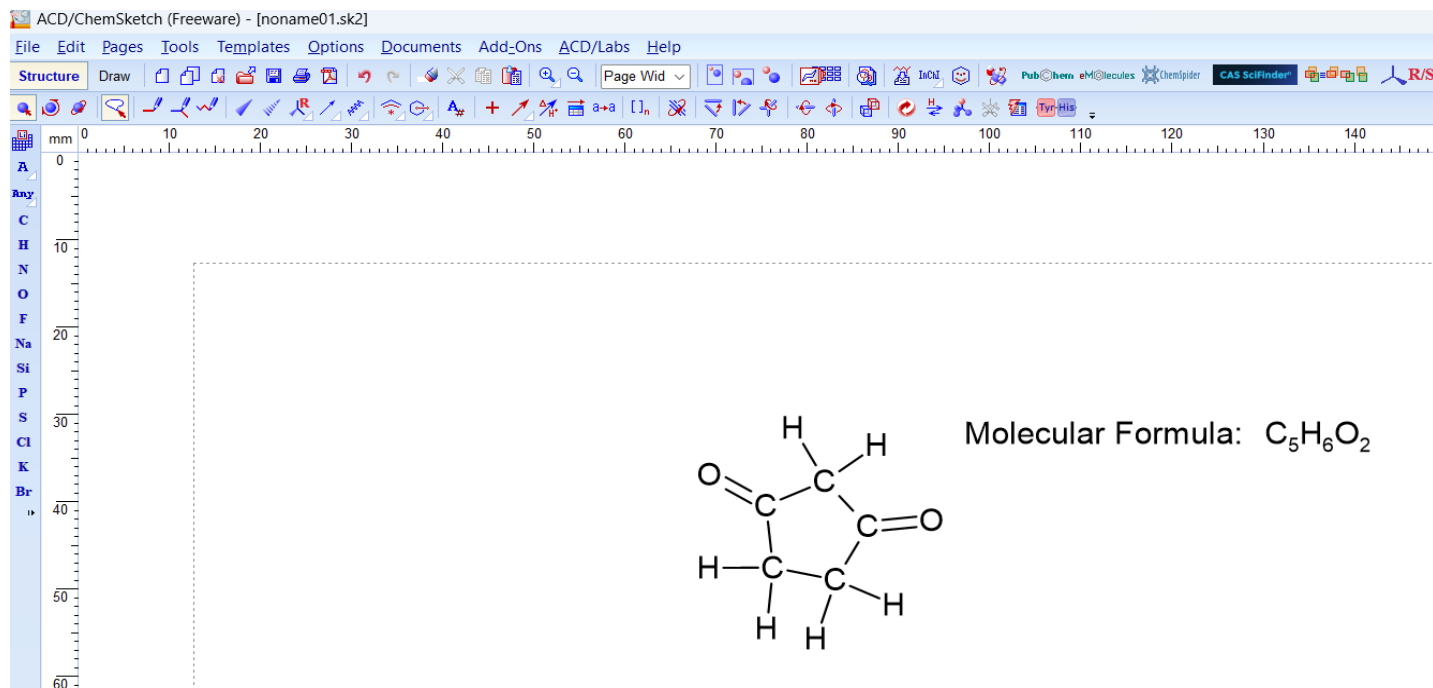

Figure 5. Structural and molecular formula of cyclopentane-1,3-dione

STEP 6

Transfer the structure to *3D Viewer*. Rotate the structure and use different ways of displaying it.

STEP 7

Save the structure and 3D models by clicking *File* and then *Save As*.

1.4. Examples of Tasks for Processing Teaching Content

Draw one of cis/trans isomers of citral (3,7-dimethylocta-2,6-dienal), a component of lemongrass essential oil and do the following:

- a) clean the structure,
- b) generate the name and determine the molecular formula,
- c) display it in the 3D viewer and rotate it,
- d) save the structure and 3D model.

1.5. Examples of Students Evaluation Tasks

Draw the structure of butandial and 5-methylheptane-2,4-dione and do the following:

- a) clean the structure,
- b) generate the name and determine the molecular formula,
- c) display it in the 3D viewer and rotate it,
- d) save the structure and 3D model.

Search the Internet and find examples of aldehydes and ketones to draw, generate names and molecular formulas in *ChemSketch*, and display it in the 3D viewer.

BIOMOLECULES

Teaching unit: Biomolecules
Unit title: Biomolecules
Estimated number of hours: 3

4.1. Theoretical introduction to the chapter

Biomolecules, also called biological molecules, are substances that are produced and used by organisms. Biomolecules have different structures and functions. The four major types of biomolecules are carbohydrates, lipids, proteins, and nucleic acids. Carbohydrates are the major source of energy for organisms. Lipids have various functions as forms of energy or building biological membranes. Proteins also have many structures and functions as transport of some important substances, working as enzymes, building muscles, or acting as antibodies. Nucleic acids have a unique function for protein synthesis and as the carrier of genetic information.

4.2. Educational outcomes of the selected chapter

- to draw different examples of carbohydrate molecules and show their structure using Fisher's and Haworth's formulas
- to generate the carbohydrate name in ChemSketch
- to describe the chemical properties of different carbohydrates
- to draw the “D” and “L” structures of different monosaccharides
- to save on the computer the structures of molecules of different carbohydrates

4.3. Instructions for using the *ChemSketch* software for selected chapter

4.3.1: How to draw a molecule of glucose using the Fischer formula?

STEP 1

Start in module *Structure* and click on *Templates*.

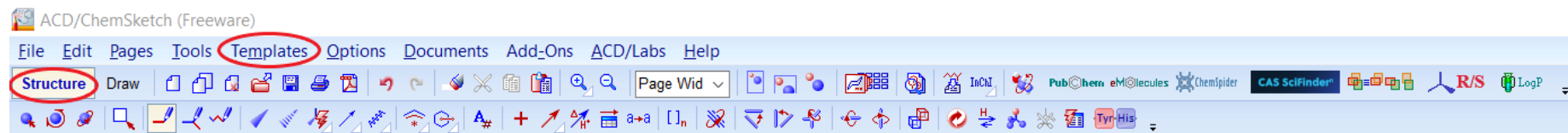

Figure 1. Sequence of action to display templates.

STEP 2

Open the *Template window*, switch to the *Draw mode* and click on *Carbohydrates*, click on D-glucose formula, and move it to the file opened.

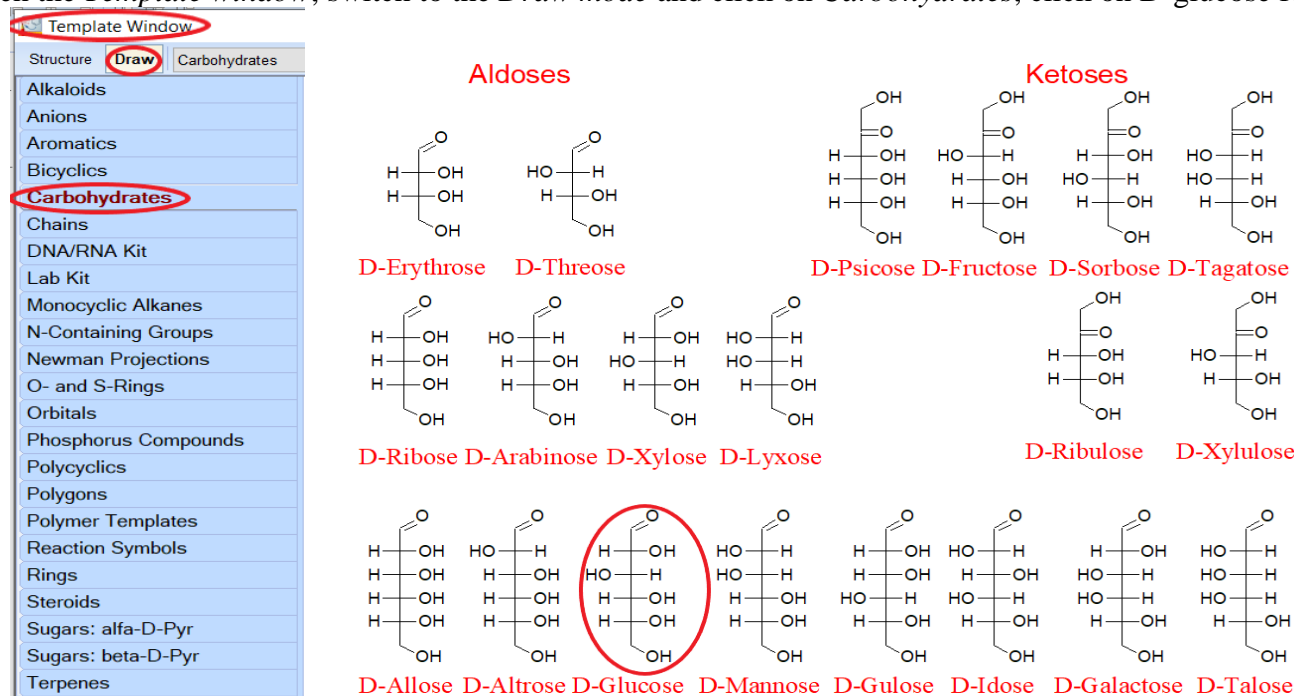

Figure 2. Selecting the structure of monosaccharides from the menu of the *ChemSketch* program

STEP 3

Switch to the *Structure* mode and label the formula.

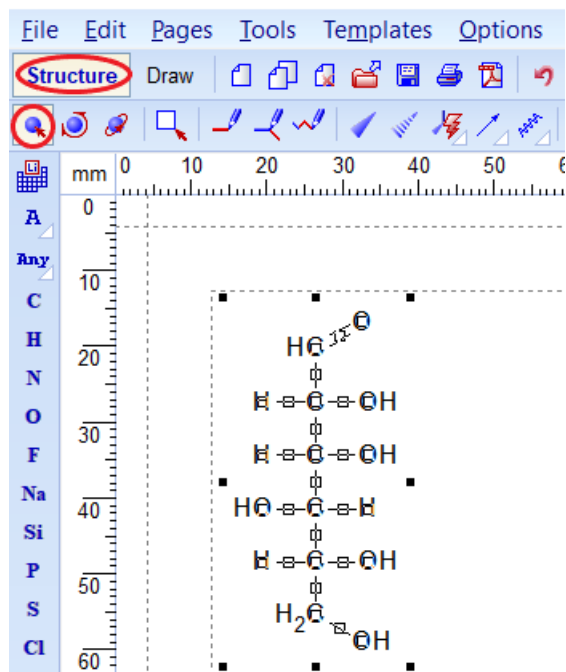

Figure 3. Switching to structure mode

STEP 4

Click on the *Tools* and choose *Structure properties*, switch to *All*.

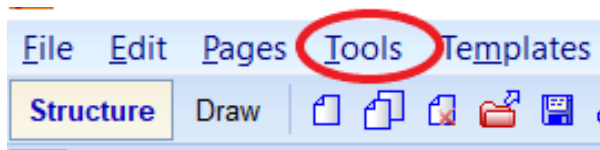

Figure 4. Sequence of action to structure properties

STEP 5

Click on *Apply* to draw the final Fischer formula with all atoms.

The screenshot shows the 'Properties' dialog box with the following settings:

- Current Style: AUTOSAVE
- Markush: Common
- Biosequence: Atom
- Coloration: Bond
- Show Carbons: All, Terminal, Hide Zero Charge, Cross Out Invalid Atom (all checked)
- Size Calculation: Auto (checked), Atom Symbol Size: 10, Bond Length: 7 mm
- Atom Style: Arial, Bold (checked), Italic (checked)
- Bond Style: 0.7 pt
- Buttons: Apply (circled in red), Set Default, Update From, Restore Default

The Fischer projection of D-glucose is shown to the right of the dialog box:

$$\begin{array}{c} \text{HC}=\text{O} \\ | \\ \text{H}-\text{C}-\text{OH} \\ | \\ \text{H}-\text{C}-\text{OH} \\ | \\ \text{HO}-\text{C}-\text{H} \\ | \\ \text{H}-\text{C}-\text{OH} \\ | \\ \text{H}_2\text{C}-\text{OH} \end{array}$$

Figure 5. Setting of structure and Fisher formula for D – glucose

4.3.2. How to generate the name of the structure?

STEP 1

Draw a molecule in module *Structure*, click on some place in the document to label the formula.

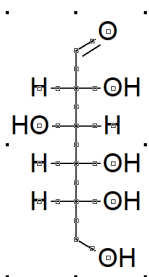
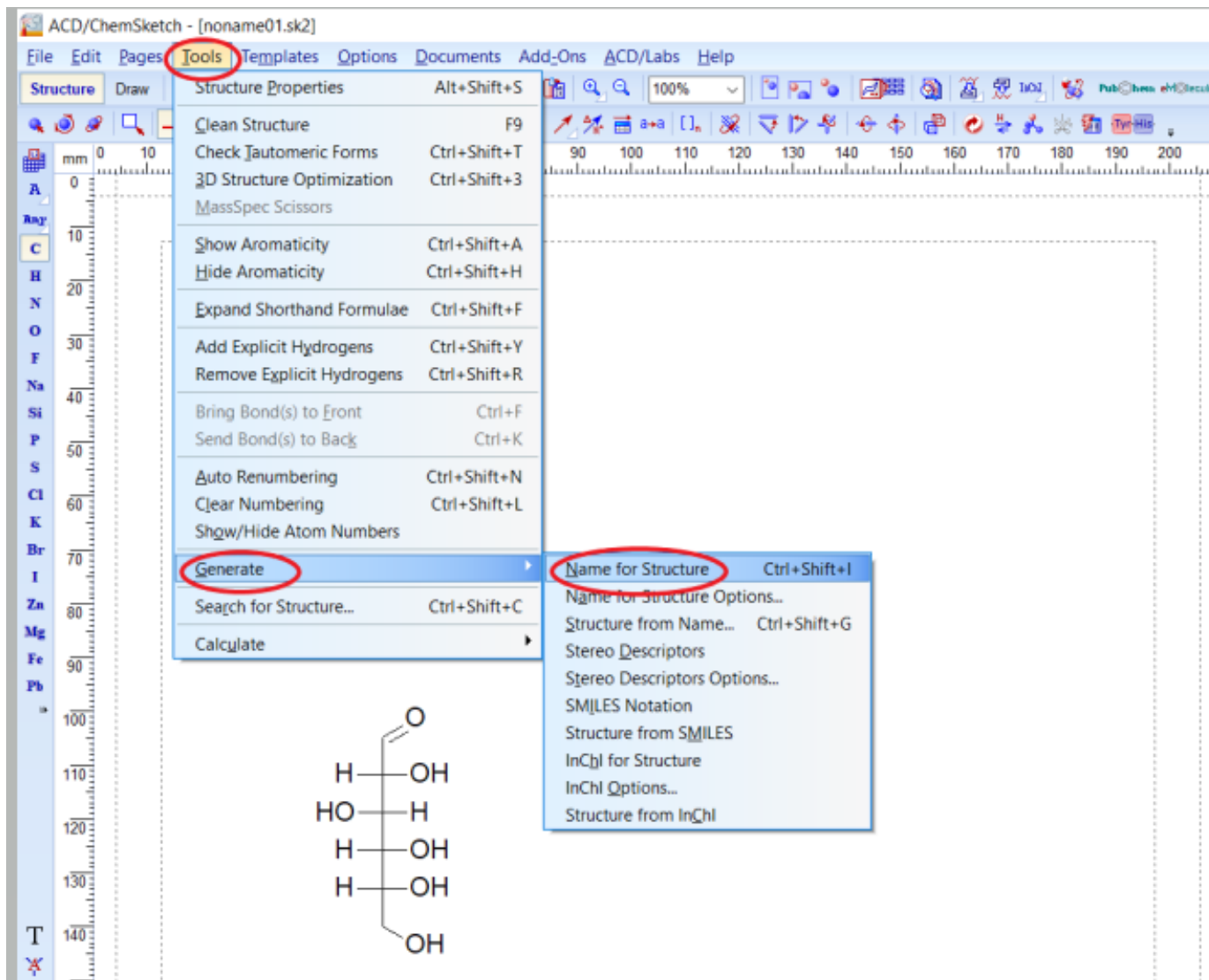

Figure 6. Structure of D-glucose

STEP 2

Click on *Tools* and choose *Generate*.



The screenshot shows the ACD/ChemSketch interface. The 'Tools' menu is open, and the 'Generate' option is highlighted. A sub-menu is also open, showing the 'Name for Structure' option highlighted. The background shows a Fischer projection of D-glucose.

2,3,4,5,6-pentahydroxyhexanal
(D-Glucose)

Figure 7. Sequence of action to create a name of the structure.

4.3.3. How to draw a molecule of glucose and generate its name by using the Haworth formula?

STEP 1

Start in module *Draw*, click on *Templates*.

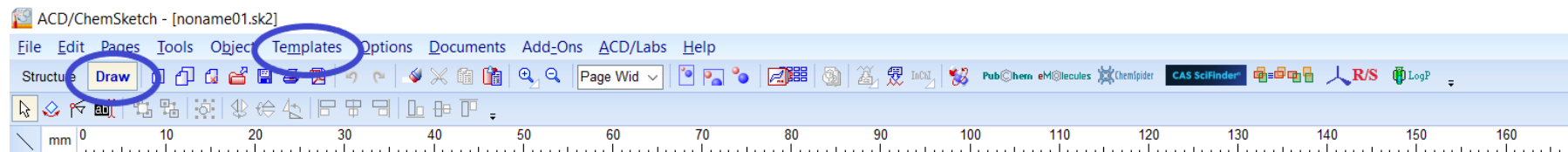

Figure 8. Sequence of action to display templates

STEP 2

Open the *Template Window*, switch to the *Draw* mode and click on Sugars:alfa-D-Pyr click on α -D-glucopyranose formula and move it to file opened.

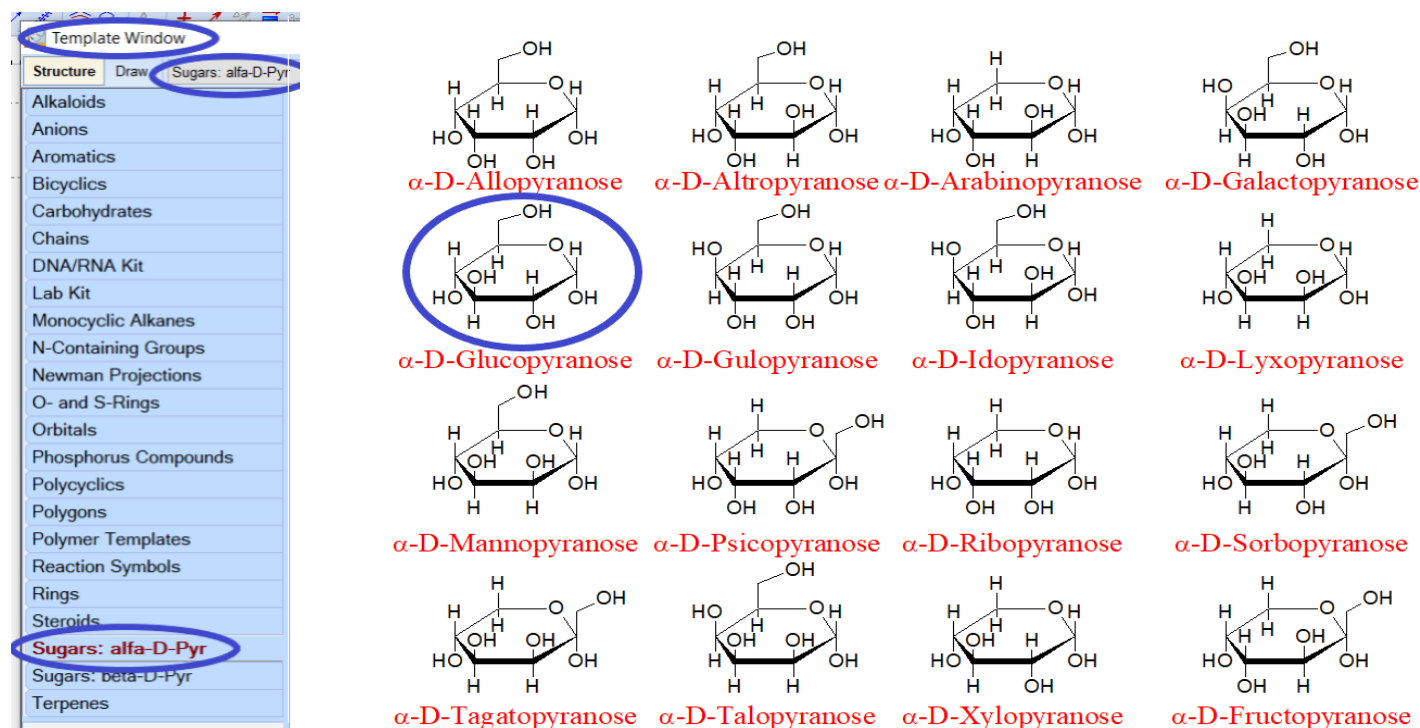
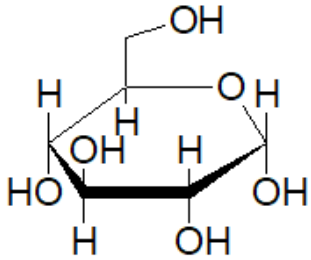

Figure 9. Selecting the structure of monosaccharides from the menu of the *ChemSketch* program

STEP 3

To generate the name of the structure you can use the same way as to generate a name for Fischer's structures or you can click on the name under the formula.



α -D-Glucopyranose

Figure 10. Formula of α -D-glucopyranose

4.3.4. How to choose properties?

STEP 1

Draw a molecule in module *Structure*, click on some place in the document to label the formula.

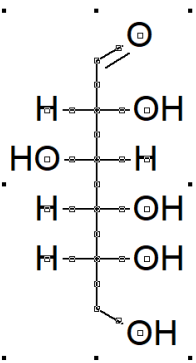

Figure 11. Structure of D-glucose

STEP 2

Click on the icon to select *Properties*.

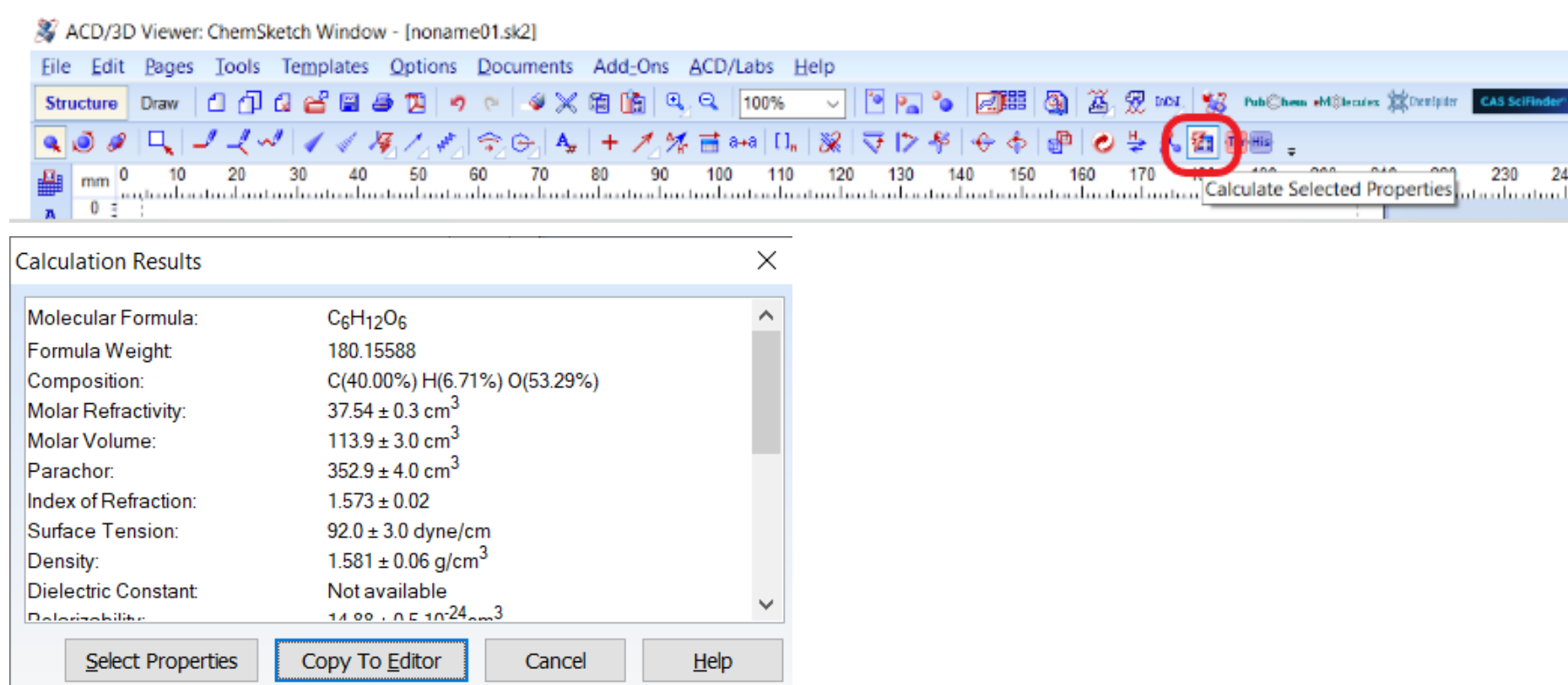

Figure 12. Sequence of action for selecting properties of a structure

STEP 3

Choose *Select Properties*.

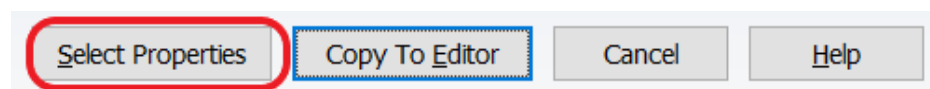

Figure 13. Continue with the process of generating properties

STEP 4

Click on *Unselect All* and choose properties, then *OK*.

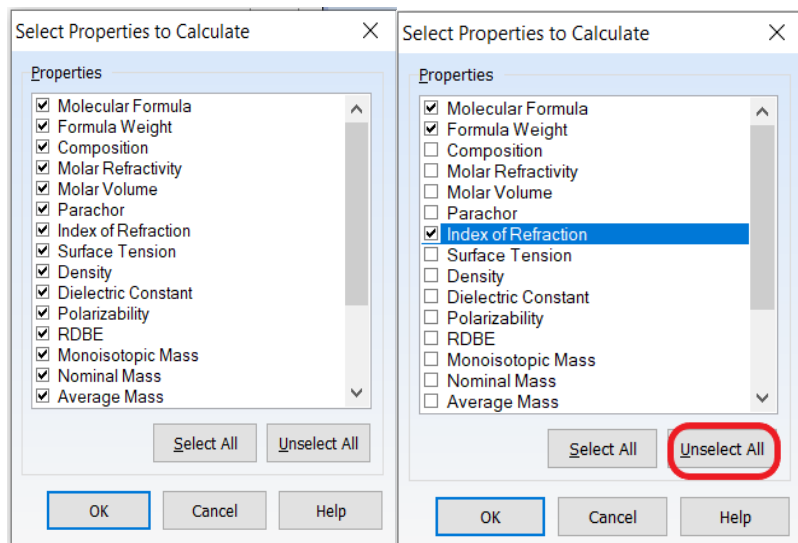

Figure 14. Selecting correct properties

STEP 5

Click on the icon, then *Copy to editor*.



Figure 15. Copy icon

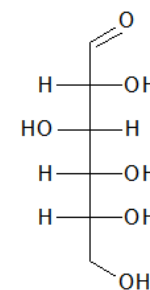
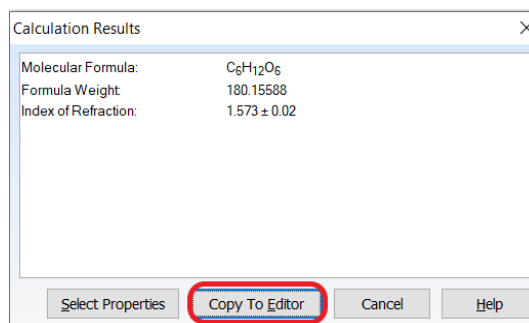

Molecular Formula: C₆H₁₂O₆
Formula Weight: 180.15588
Index of Refraction: 1.573 ± 0.02

Figure 16. Copying of selected properties

4.3.6 Transfer the molecules of D-glucose and α -D-glucopyranose to 3D structure.

STEP 1

Label the Fischer formula and click on the *3D Viewer*.

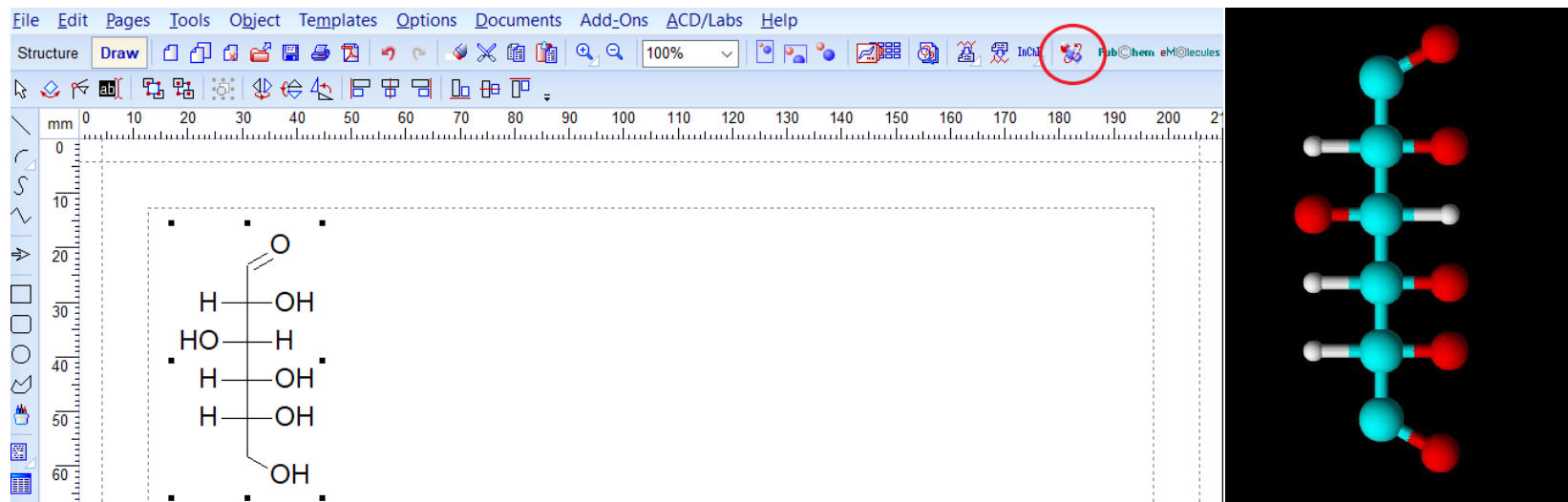

Figure 17. Labeling structure

STEP 2

Label the Haworth formula and click on the *3D Viewer*.

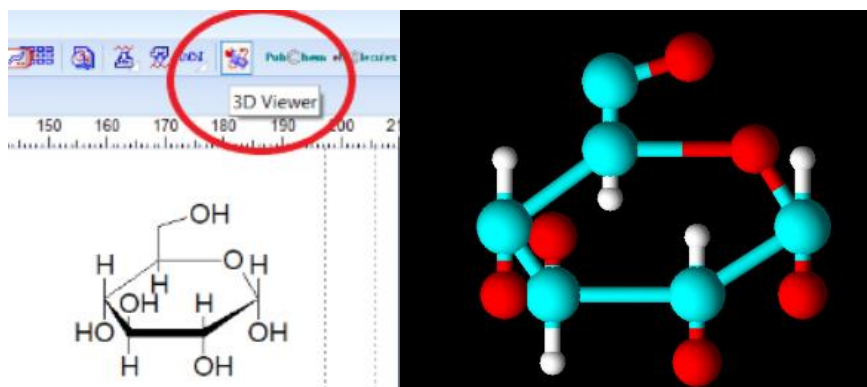

Figure 18. Haworth formula for D-glucose

4.3.7. Use icons of specific ways for lengths and atoms

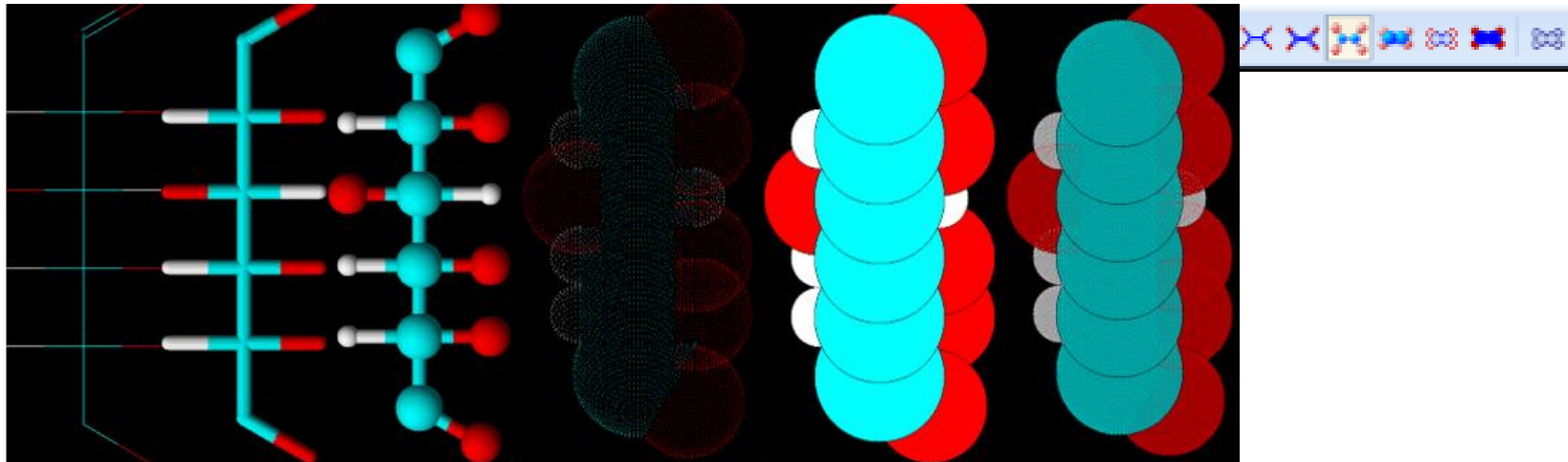

Figure 19. Types of formulas in a 3D model

4.3.8. Use icons of all kinds of rotations

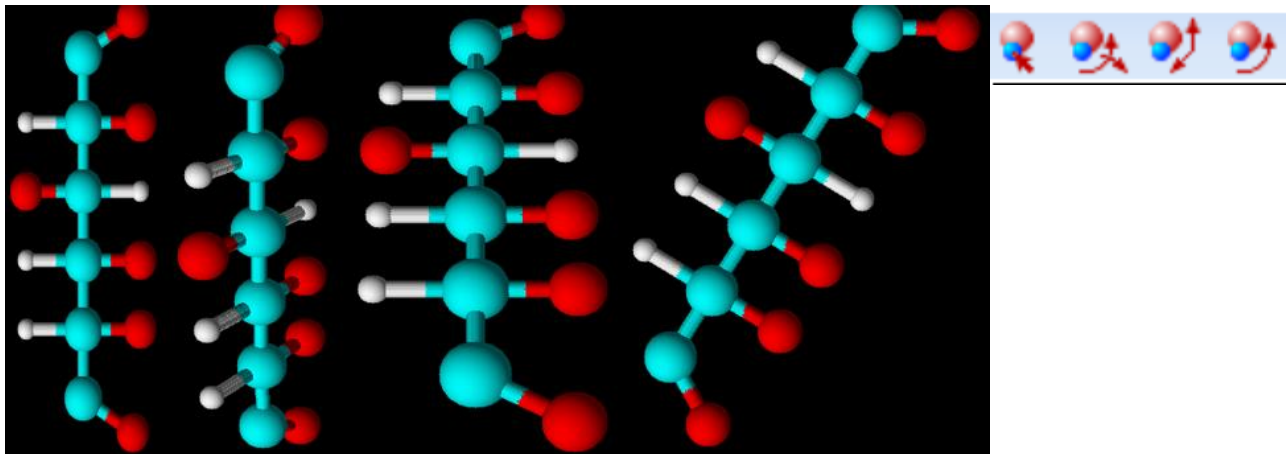

Figure 20. Different angle of monosaccharides

4.4. Examples of tasks for processing teaching content

Research on the Internet what a molecule of fructose looks like and display the molecule in the *ChemSketch* program. When you have represented a molecule of fructose, explore how the molecule looks in 3D form and apply the learned functions in *ChemSketch*.

1. Draw the fructose by using templates and do the following with it:

- a) draw two types of carbohydrates structures,
- b) draw Fischer and Haworth formulas,
- c) edit the structure of the molecule, undo or change atoms and functional groups,
- d) generate the name for the structure,
- e) display the structure of the molecule in the *3D Viewer*,
- f) use icons of all kinds of rotations and icons of specific ways for lengths and atoms,
- g) find molecular formula, formula weight and index of refraction.

2. Explore the applications of biomolecules. Select one biomolecule to display in the *ChemSketch* program. Write in your notebook the application of the chosen molecule in everyday life and its sources (occurrence). Save the 3D structure of these molecules to your computer.

4.5. Examples of student evaluation tasks

Research on the Internet what a molecule of galactose looks like and display the molecule in the *ChemSketch* program. When you have represented a molecule of galactose, explore how the molecule looks in 3D form and apply the learned functions in *ChemSketch*.

1. Draw the galactose by using templates and do the following with it:
 - a) draw two types of monosaccharide structures,
 - b) draw Fischer and Haworth formulas,
 - c) edit the structure of the molecule, undo or change atoms and functional groups,
 - d) generate the name for the structure,
 - e) display the structure of the molecule in the *3D Viewer*,
 - f) use icons of all kinds of rotations and icons of specific ways for lengths and atoms,
 - g) find molecular formula, formula weight and index of refraction.
2. Write in your notebook the biological significance of galactose and its sources (occurrence).

COORDINATION COMPOUNDS

1.) ELABORATION OF THE UNIT TITLE

Teaching unit: Transition Metals
Unit title: Coordination Compounds
Estimated number of hours: 2

1.1. Theoretical introduction

Coordination compounds, also known as coordination complexes, are compounds consisting of a central metal ion (also known as the coordination center) surrounded by a group of ligands. Ligands are anions or neutral molecules which can donate a pair or pairs of electrons and that are bonded to the metal ion through coordinate covalent bonds. Ligands can monodentate, bidentate or polydentate. A coordinate covalent bond is a covalent bond in which one atom from the bond (donor atom) supplies both electrons. This type of bonding is different from a normal covalent bond in which each atom supplies one electron.

Complexes can be neutral or charged. When the complex is charged, it is stabilized by neighboring counter-ions.

If the ion has a previously described complex structure, it is called a complex ion, but if there is no net charge (when there is interaction between cation and complex anion, complex cation and anion or both complex cation and anion), then it is called a coordination compound.

The coordination number is the number of donor atoms bonded to the central metal atom/ion.

Many coordination compounds have distinct geometric structures. Two common forms are the square planar, in which four ligands are arranged at the corners of a hypothetical square around the central metal atom, and the octahedral, in which six ligands are arranged, four in a plane and one each above and below the plane.

Coordination compounds have the ability to exhibit isomerism, which is the existence of different compounds with the same chemical formula but different arrangements of the ligands around the metal ion. This leads to different physical and chemical properties, making coordination compounds useful in a variety of applications, such as catalysts, pigments, and therapeutic agents.

In addition to isomerism, coordination compounds often exhibit interesting color, magnetic and reactivity properties and thus play a crucial role in many areas of chemistry and have a wide range of practical applications.

Some examples

Molecular formula	Name	Ligand	Coordination number	Geometric structure
$[\text{Ag}(\text{NH}_3)_2]^+$	Diamminesilver(I) ion	NH_3	2	Linear
$[\text{Zn}(\text{CN})_4]^{2-}$	Tetracyanozincate(II) ion	CN^-	4	Tetrahedral
$[\text{Ni}(\text{CN})_4]^{2-}$	Tetracyanonickelate (II) ion	CN^-	4	Square planar
$[\text{PtCl}_6]^{2-}$	Hexachloroplatinate (IV) ion	Cl^-	6	Octahedral
$[\text{Co}(\text{NH}_3)_6]^{3+}$	Hexaamminecobalt(III) ion	NH_3	6	Octahedral
$[\text{Pt}(\text{NH}_3)_2\text{Cl}_2]$	Diamminedichloroplatinum(II)	NH_3, Cl^-	4	Square planar Cis-trans isomers

1.2. Educational Outcomes

In this chapter students will learn:

- to draw different examples of coordination ions and compounds and show them with a structural formula.
- to show the structures of coordination compounds in 2D
- to display 3D models of coordination compounds drawn in 2D using the program option *3D Viewer*

- to determine the coordination number and geometry of coordination compounds
- to determine possible geometric isomers of coordination compounds
- to determine the coordination number and shape of the drawn coordination compound
- to show the structure of coordination compounds in three dimensions
- to rotate coordination structures in two and three dimensions
- to change the three-dimensional display of the coordination ion structure
- to move the structures of coordination compounds in 2D and 3D
- to determine/correct bond lengths and bond angles in coordination ions
- to optimize the structure of the coordination compound
- to save on the computer the two-dimensional and three-dimensional structure of the desired coordination ion or compound.

1.3. Instructions for Using the *ChemSketch* Program

Example 1

Draw $[\text{Ag}(\text{NH}_3)_2]^+$, display the structure of the ion in three dimensions in different ways, and determine the bond angles.

STEP 1

Select the *Structure mode*. Select Ag from the left side toolbar or select the Periodic table (left side toolbar) and choose Ag and click on an empty area of the page. (**Figure 1a and 1b**). When you use an element for the first time, you have to select it from the periodic table, later it appears at the left side of the toolbar.

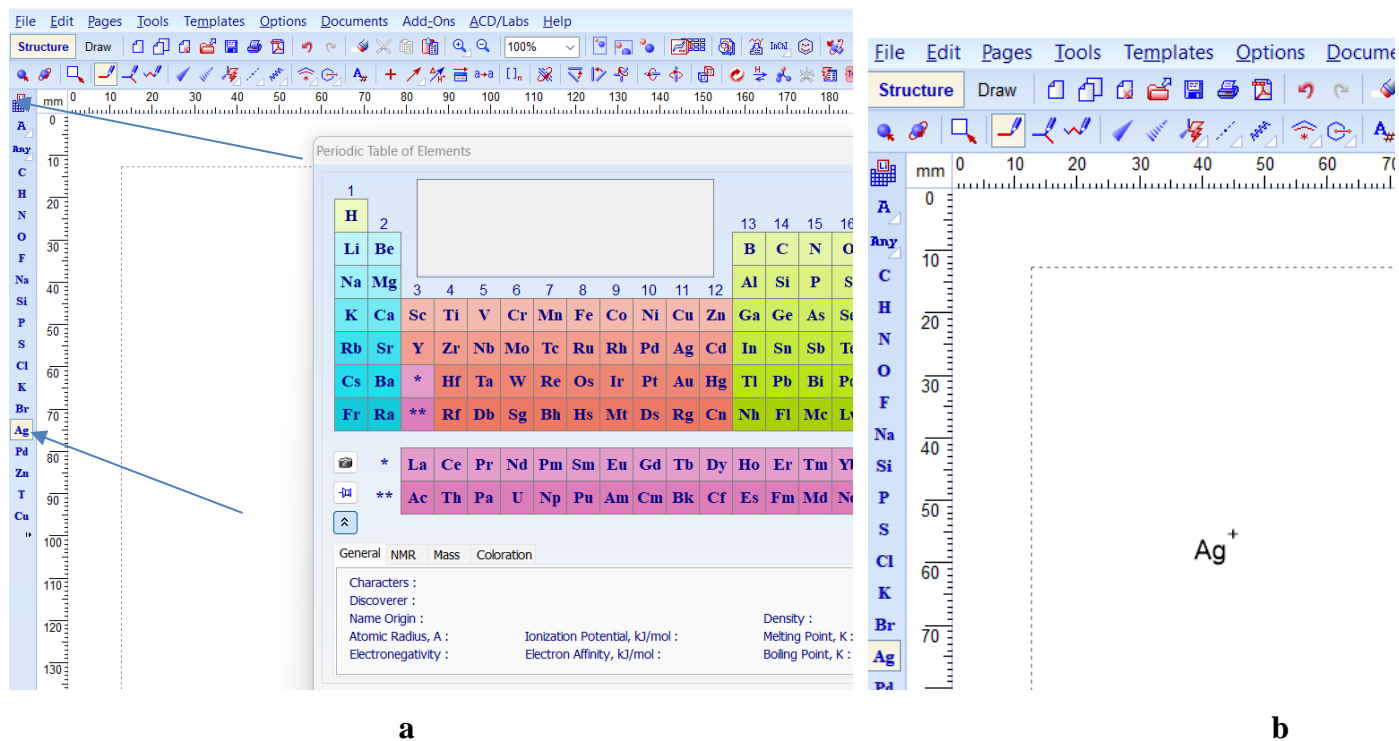

Figure 1. a) Selection of the wanted element, b) Ag selected

STEP 2

Select the *DrawNormal* option, select N from the left side toolbar (or from the periodic table) and draw bonds at each side of Ag. **Figure 2.**

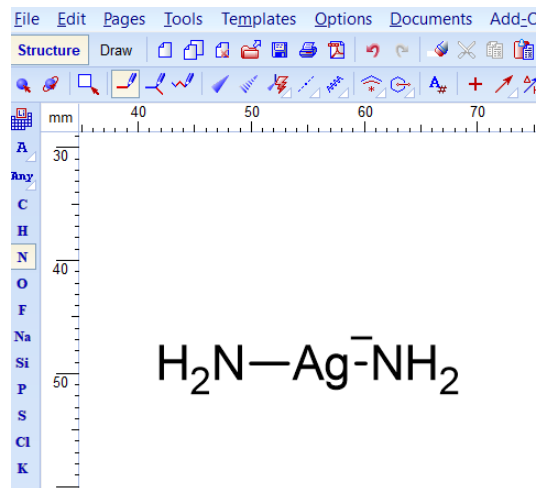
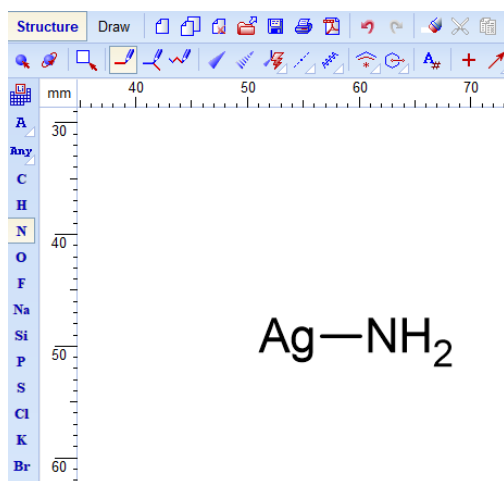

Figure 2. Drawing Ag-N bonds.

STEP 3

Draw three N-H bonds (nitrogen-hydrogen) at each N. **Figure 3 a and 3 b.** Repeat at other N atom.

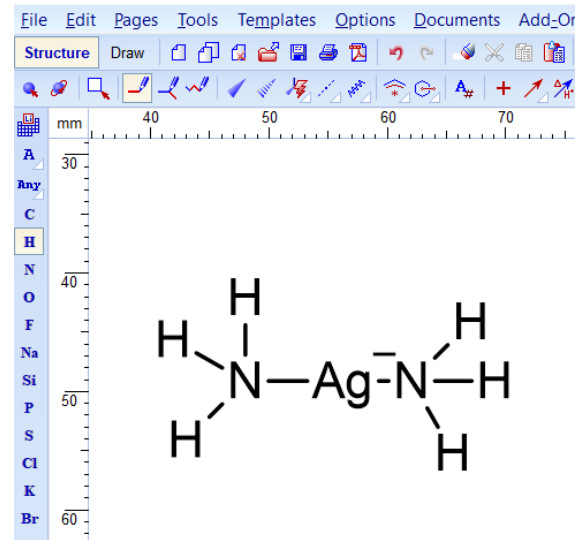
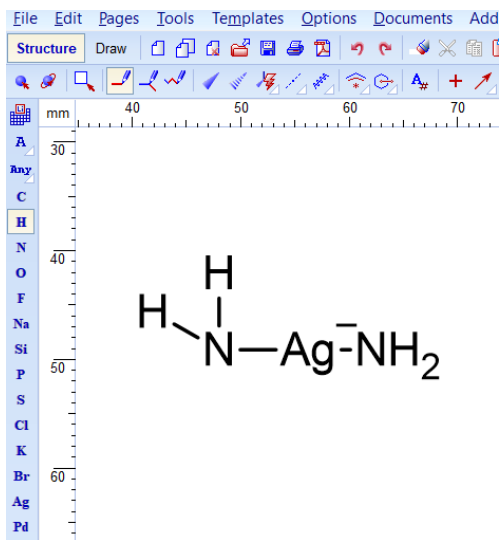

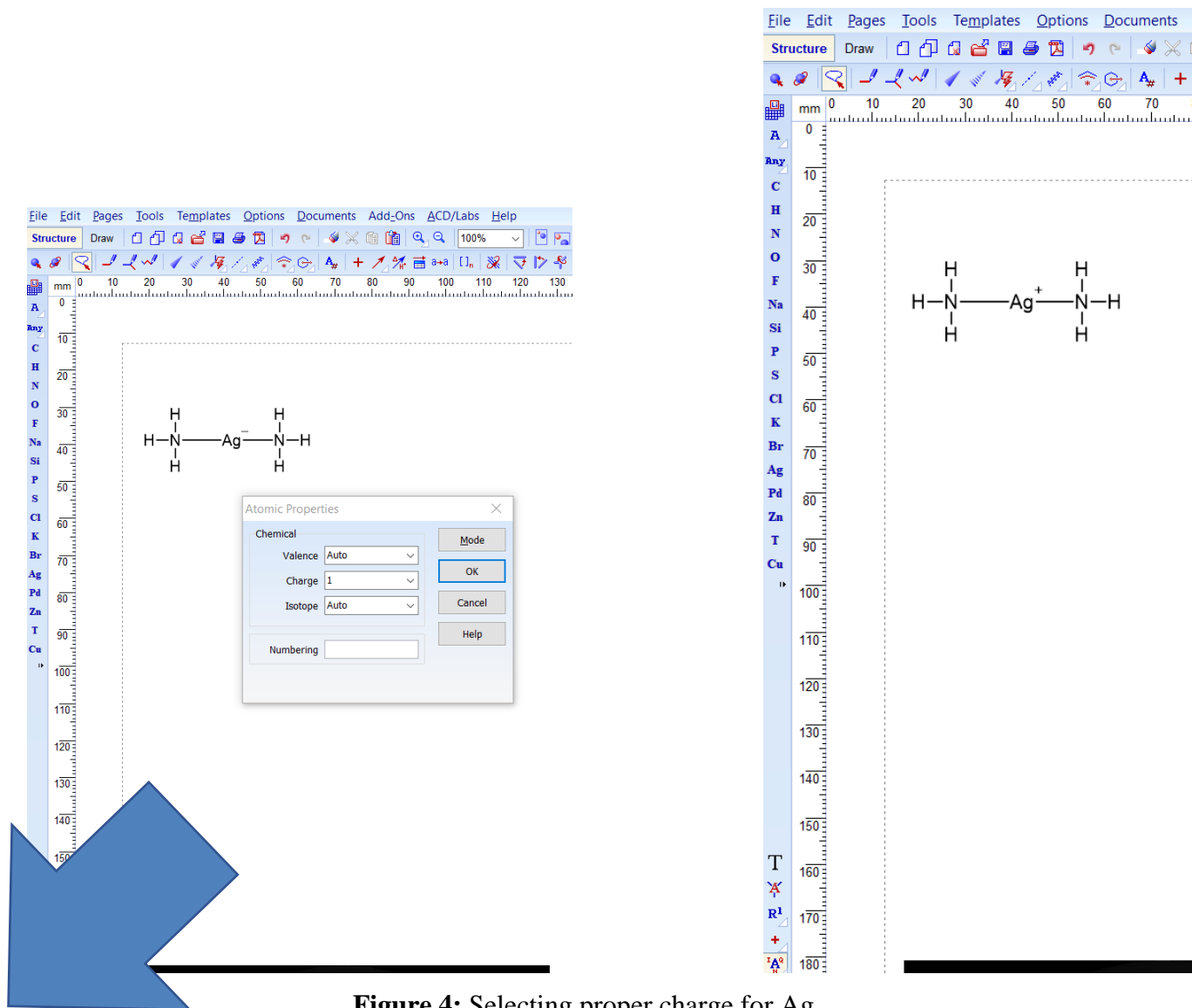

Figure 3. Drawing N-H bonds

STEP 4

Assigning proper charge for Ag.

Select  (*Atom chemical properties*), click on Ag and change charge. Click **OK** (**Figure 4**).



The figure consists of two side-by-side screenshots of the ChemDraw software interface, illustrating the process of assigning a charge to Silver (Ag) in a chemical structure.



Left Screenshot: Shows the chemical structure of two ammonia molecules (NH_3) coordinated to a Silver (Ag) atom. The Ag atom is currently shown with a negative charge (Ag^-). An "Atomic Properties" dialog box is open, with the "Charge" field set to "1". A large blue arrow points from the bottom left towards the dialog box, indicating the next step in the process.

Right Screenshot: Shows the same chemical structure, but now the Silver (Ag) atom is correctly assigned a positive charge (Ag^+).

Both screenshots show the software's menu bar (File, Edit, Pages, Tools, Templates, Options, Documents) and a vertical periodic table on the left side. The "Structure" menu is active in both.

Figure 4: Selecting proper charge for Ag

STEP 5

We have to add brackets and charge. Switch to *Draw mode* and select brackets . **Figure 5 a.** For adding charge select  in *Draw mode* and add charge. **Figure 5 b.**

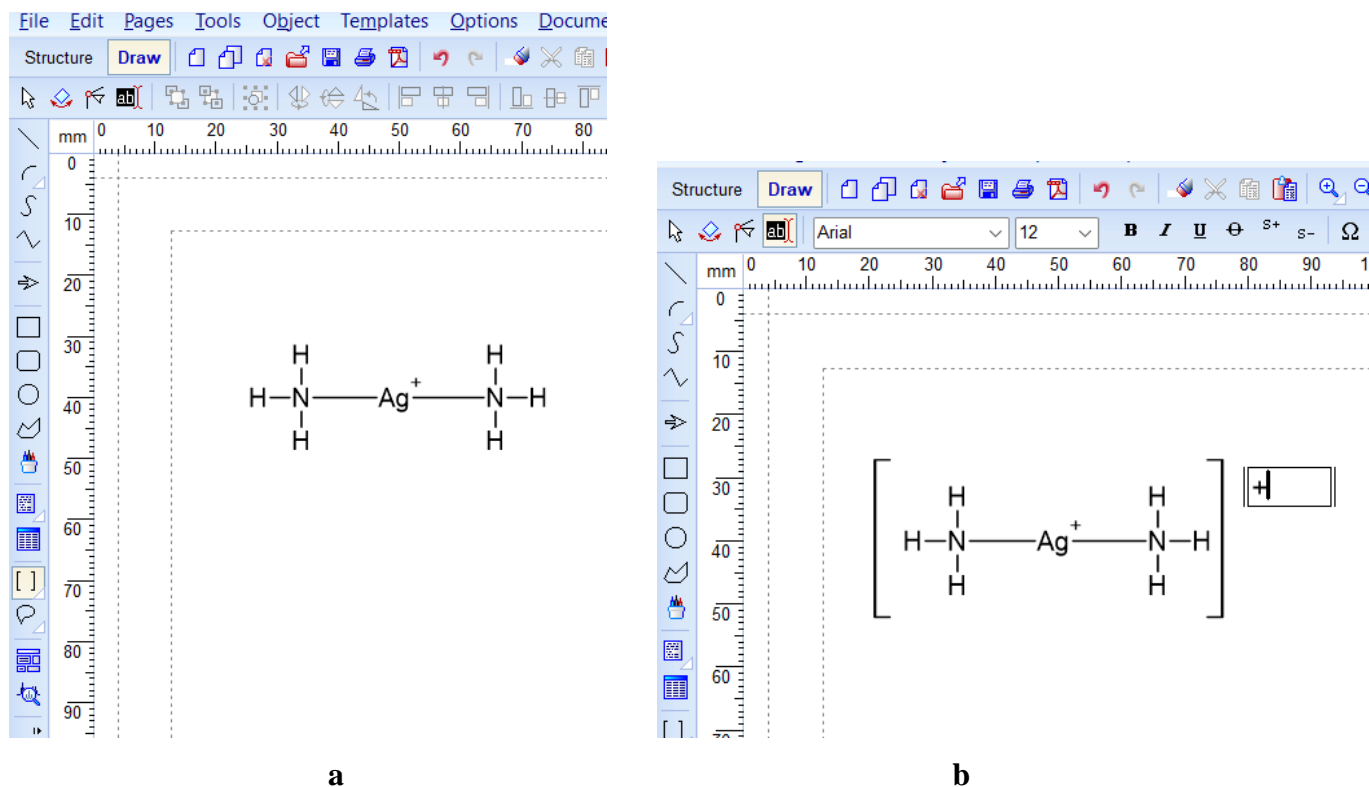



Figure 5. a) Adding brackets, b) Adding the charge

STEP 6

Display the structure in 3D by first selecting it and then clicking on the option  on the upper toolbar. A new window will open with a 3D view of the structure (**Figure 6 a and b**).

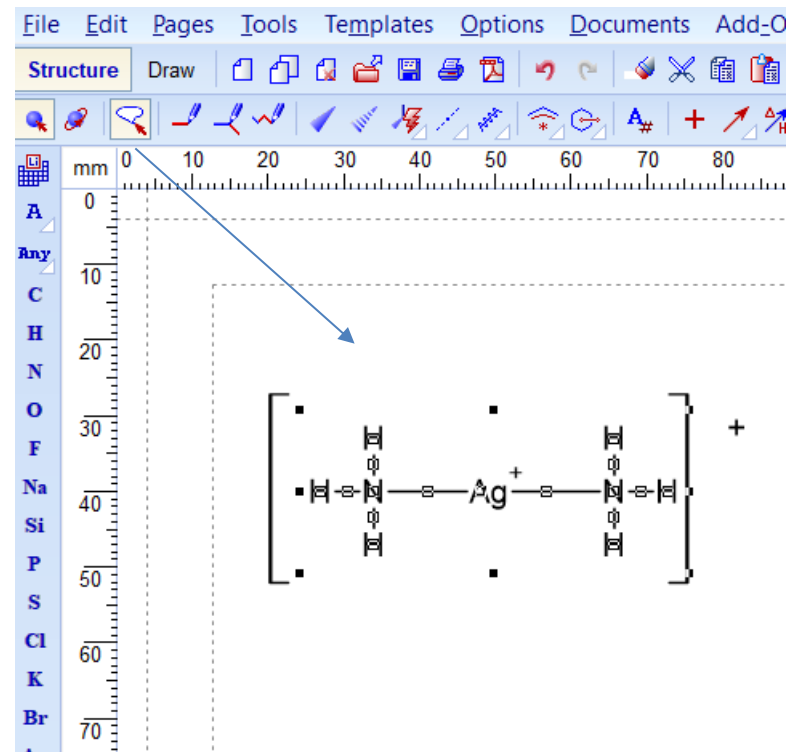

Figure 6. a) Selecting the structure

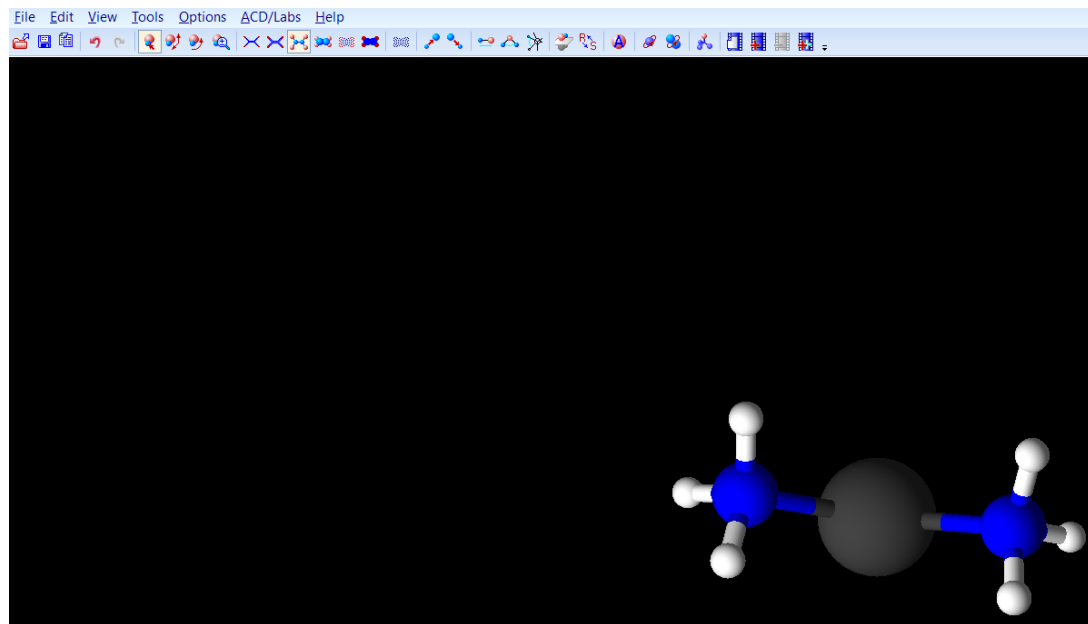



Figure 6. b) Structure in 3D mode

STEP 7

To see or to change the bond angle between two atoms, select option  (bond angle). In order to determine the bond angle between nitrogen atoms, we must click on the nitrogen atom (which changes color to green), then on silver and other nitrogen atom. A window will open with the displayed value. We can change the value to the proper one (**Figure 7**).

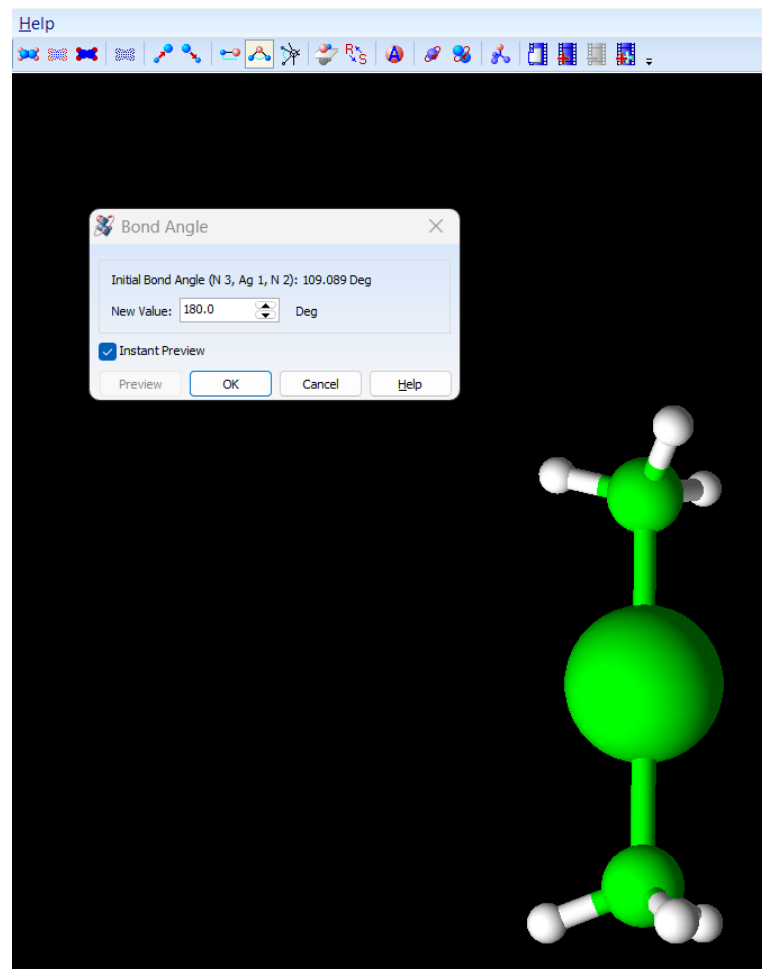



Figure 7. Determining the bond angle

STEP 8

Try using each of the rotate, move, and select options on the top toolbar: , and then display the structure in every way the program offers.

Options are displayed on the toolbar: .

Clicking on any of the options changes the way the ion is displayed. For automatic rotation of the ion, click on the icon .

For automatic continuous change from one to another structure, display the mode with rotation, by clicking on the icon .

STEP 9

Now we can return the edited structure to the *ChemSketch* program by clicking on the *Copy to ChemSketch* option and selecting the *Structure* option (**Figure 8**) at the very bottom of the interface. The optimized structure now appears in *ChemSketch*.

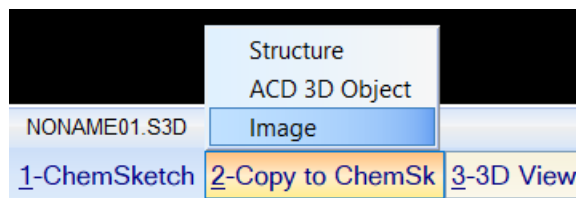

Figure 8. Moving the optimized 3D structure to *ChemSketch*

If we select *Copy to ChemSketch* and then select *Image* (**Figure 9 a and b**), we can copy the 3D structure to *ChemSketch*.

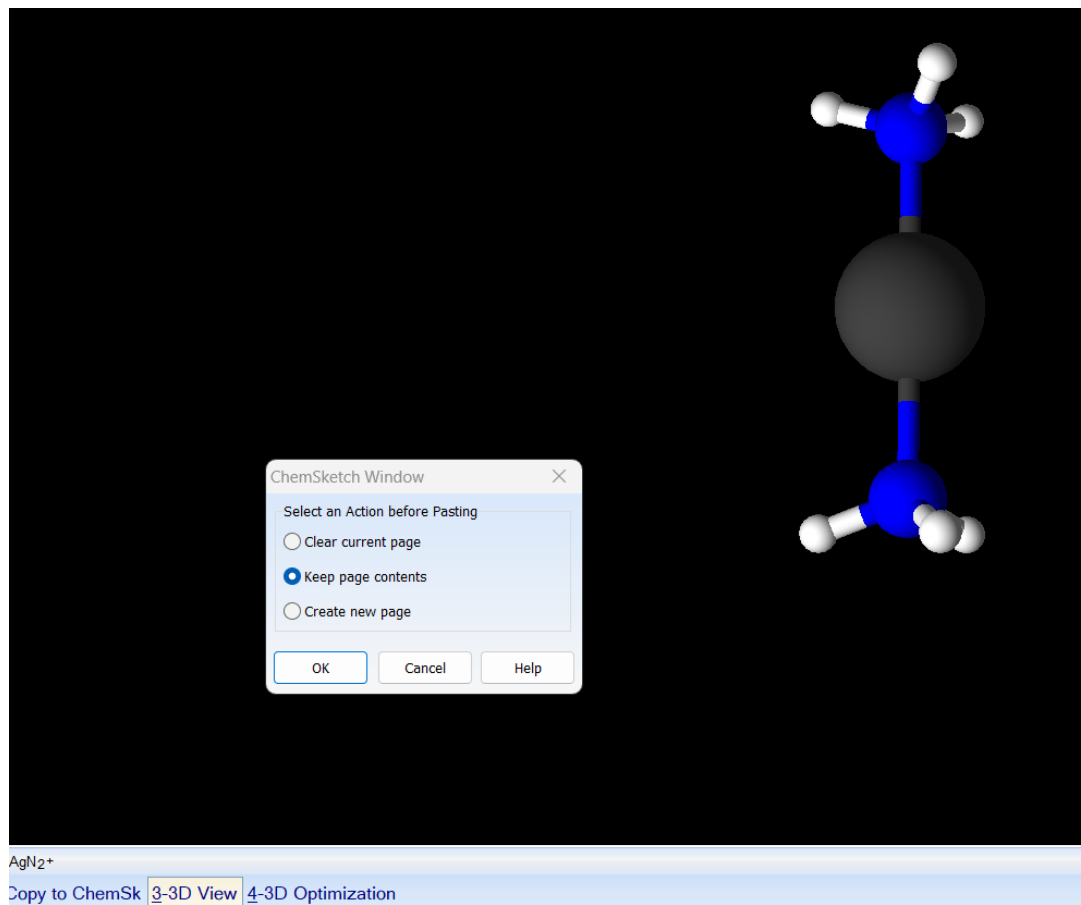

Figure 9. a) Copying the structure to *ChemSketch*

STEP 10

Save both 2D and 3D structures to your desktop by clicking *File* and then *Save As*.

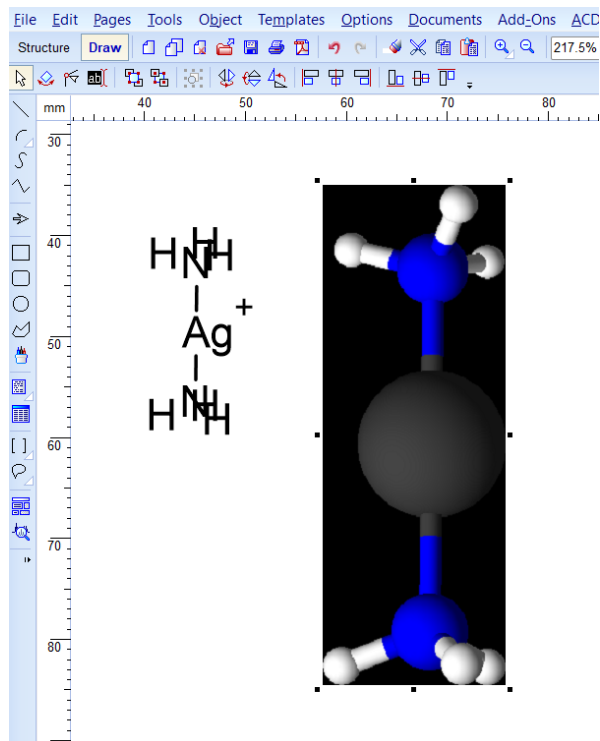

Figure 9. b) Copied structure

Example 2

Draw $[\text{Zn}(\text{CN})_4]^{2-}$. The structure is tetrahedral.

Draw the structure by following the steps previously learned (**Figures 1 to 9**). Then apply the previously learned **STEPS** from **1 to 9** in this example.

STEP 1

Start with Structure mode and select *DrawNormal*.

Select Zn from the Periodic table (left side toolbar) and insert it. Draw tetrahedral structure of the selected atom (**Figure 10**).

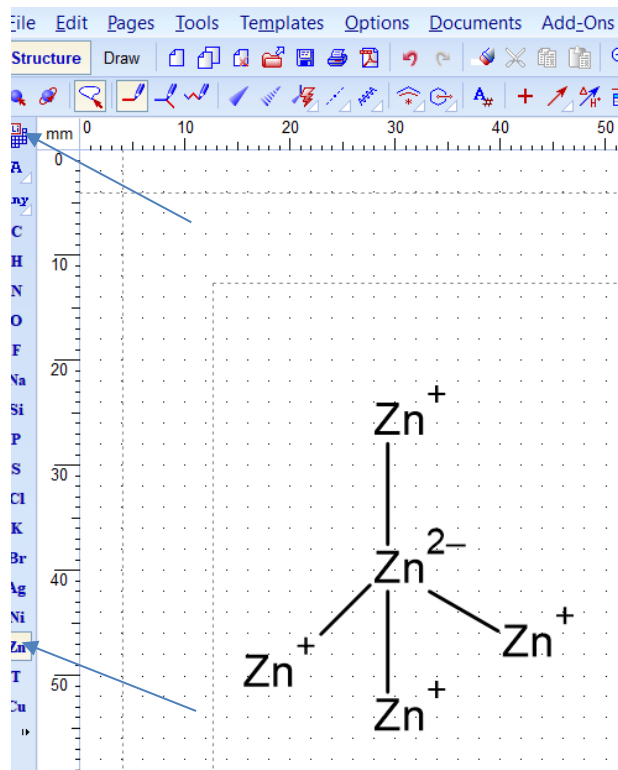

Figure 10. Drawing the tetrahedral structure

STEP 2

Replace four Zn atoms (except central one) with CN group. First select C from the left toolbar and replace Zn. (**Figure 11a**).

STEP 3

Then select N and draw a triple bond (point on the bond, a rectangle will appear around the bond, then click it to make a triple bond) on the C atom. (**Figure 11 b, c, and d**). Add proper charge on the Zn.

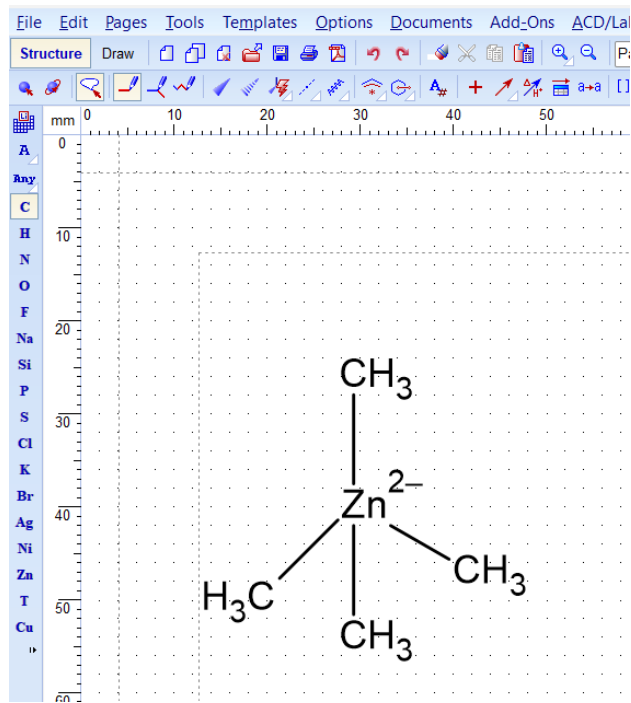

a

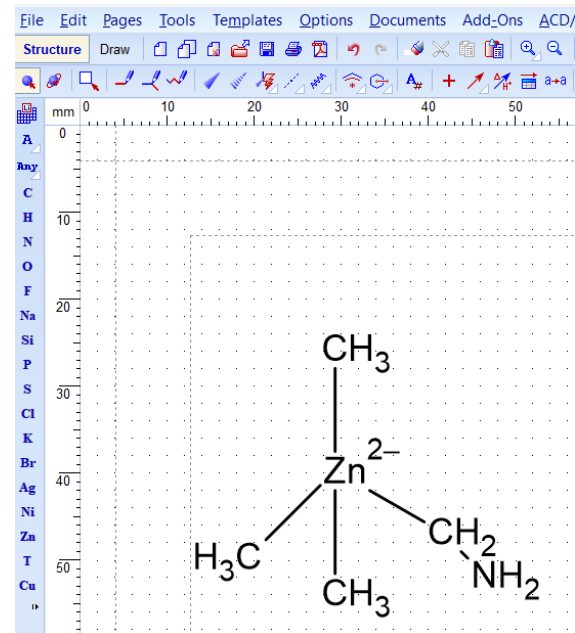

b

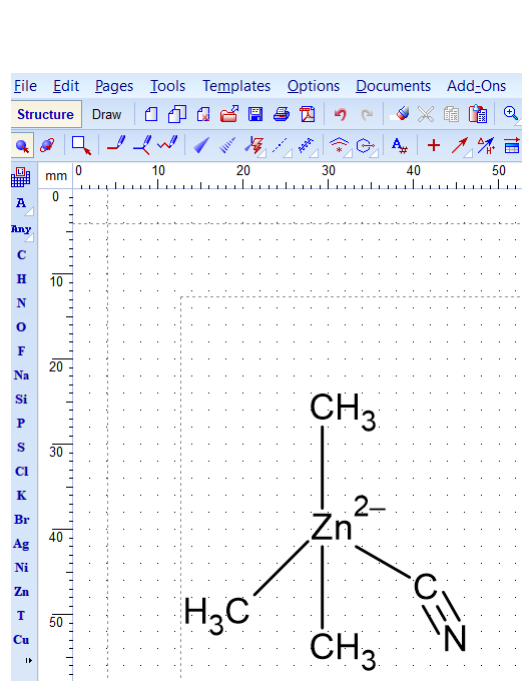

c

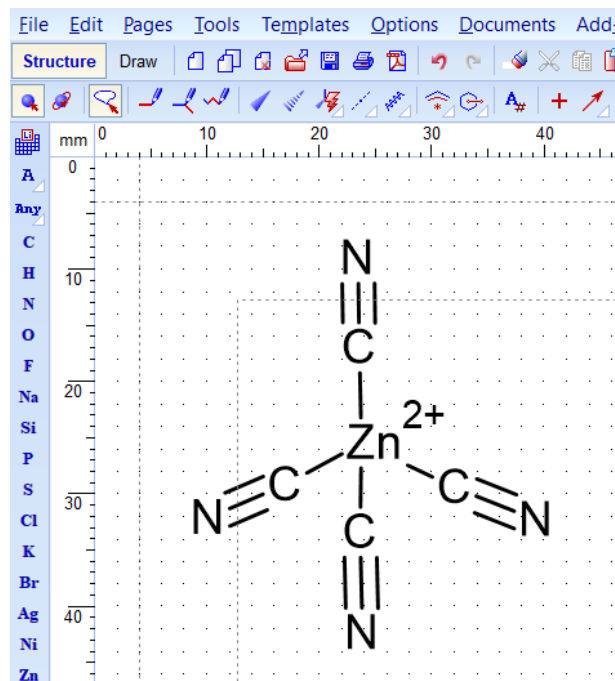

d

Figure 11. Drawing CN group – sequence of actions a) to d)

STEP 4

Use button *Select/Move* () and adjust bond length and position. (**Figure 11 d**),

STEP 5

In order to get a better structure, use the *3D Optimisation* option . Beforehand select structure with  to do optimisation. (**Figure 12**).

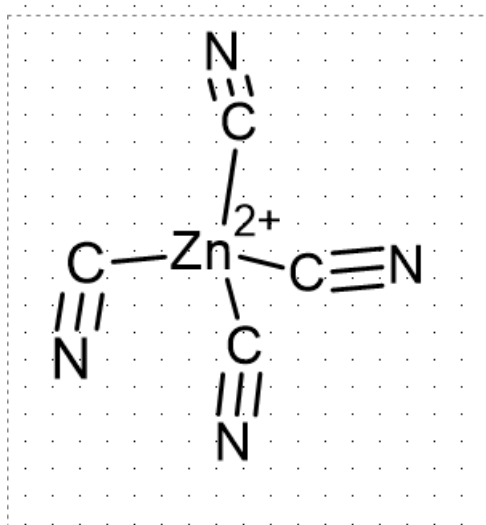

Figure 12. Structure after 3D optimization

STEP 6

Add brackets and charge of the coordination ion. See **example 1, Figure 13.**

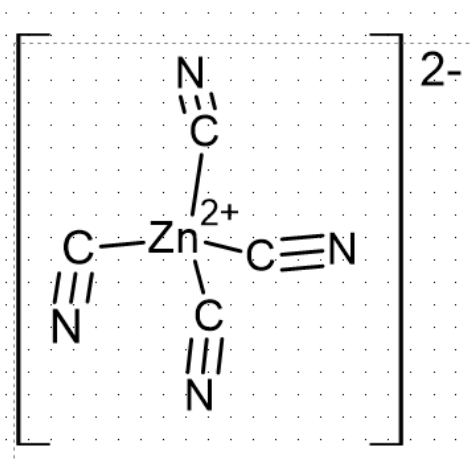

Figure 13. Structure with brackets and charge.

It is also possible to use stereo bonds instead of regular bonds, as shown in **Figure 14**. Click on the icon  and on the compound bond. Repeat with other bond.

Use icon .

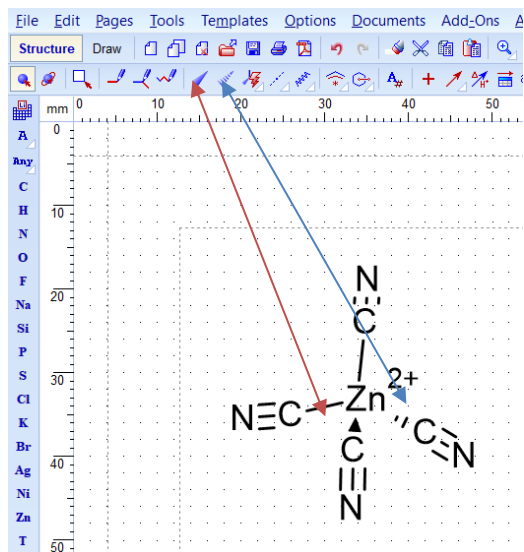

Figure 14. Structure with stereo bonds

STEP 7 Presenting structure in 3D as shown in **Figure 15**. See **example 1**.

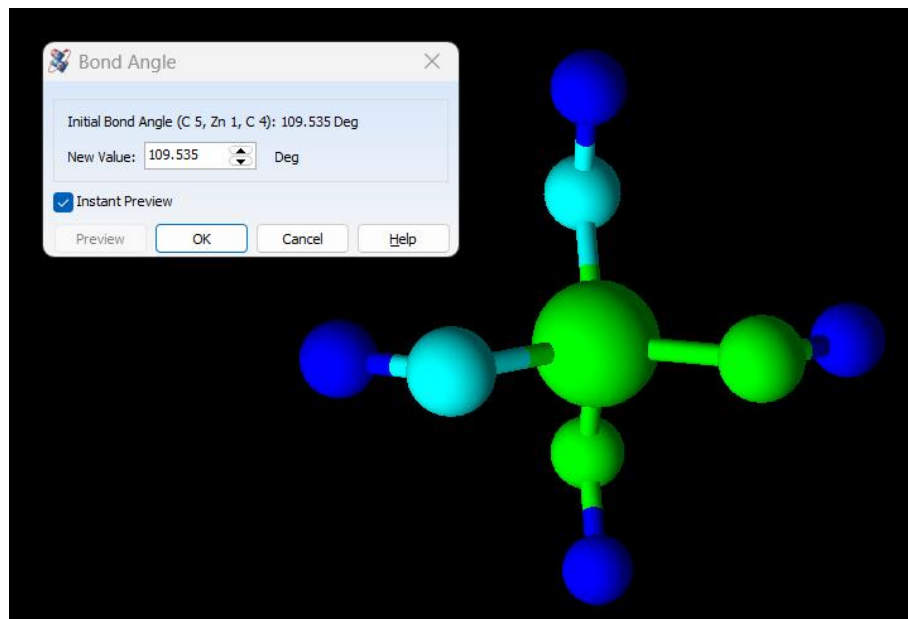

Figure 15. 3D Structure and bond angle

STEP 8

Rotate the structure (see **STEP 8, example 1**).

Example 3

Draw $[\text{Ni}(\text{CN})_4]^{2-}$. Structure is square planar.

STEP 1

Start with Structure mode and select *DrawNormal*. Follow steps from **example 1**.

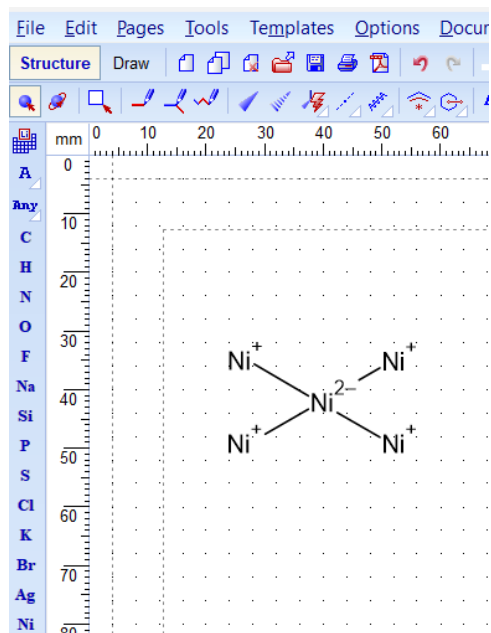

Figure 16. First step for structure $[\text{Ni}(\text{CN})_4]^{2-}$

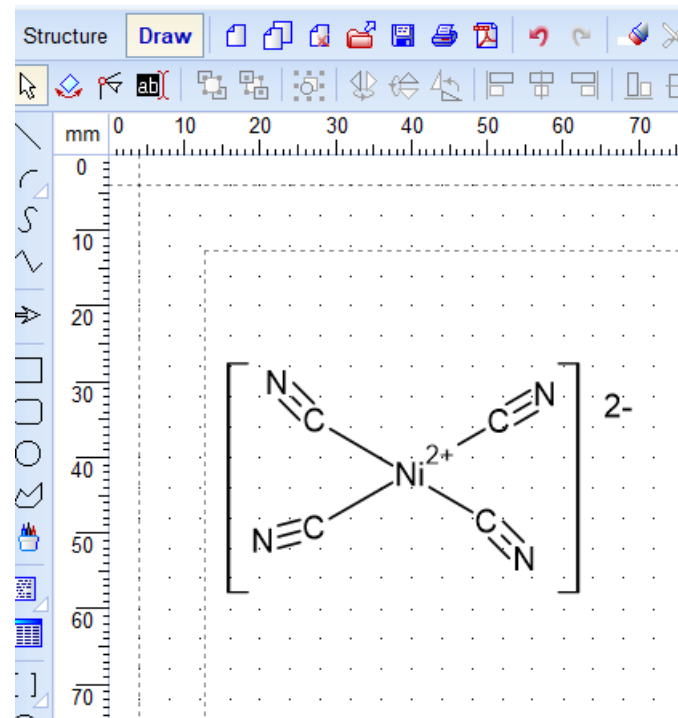

Figure 17. Structure before editing

STEP 2

Change Ni atoms with CN group as in example 2. (Figure 17).

STEP 3

Structure after editing – use the *Clean Structure* option and 3D optimization option. (Figures 18 and 19).

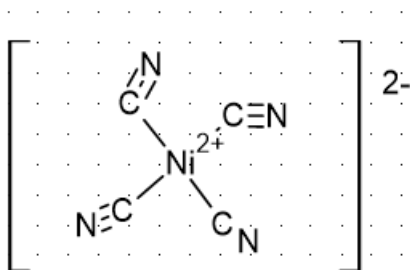

Figure 18. Structure after optimization

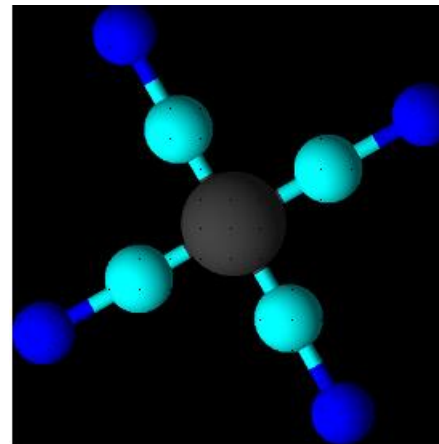

Figure 19. 3D model

Example 4 (optional)

Draw [Al(H₂O)₆]³⁺. Structure is octahedral. See steps in **examples 1 and 2**.

STEP 1

Draw octahedral structure. **Figure 20.**

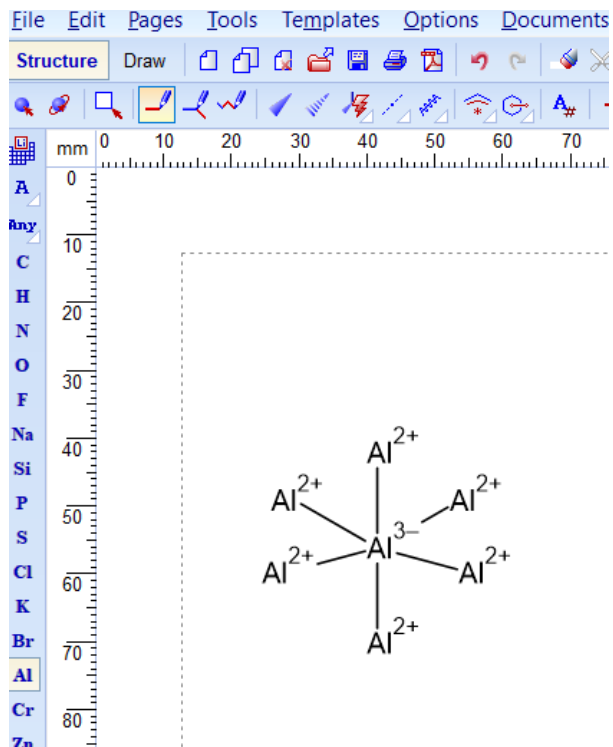

Figure 20. Octahedral structure

STEP 2

Select oxygen atom and replace 6 aluminium atoms (all but the central one). **Figure 21.**

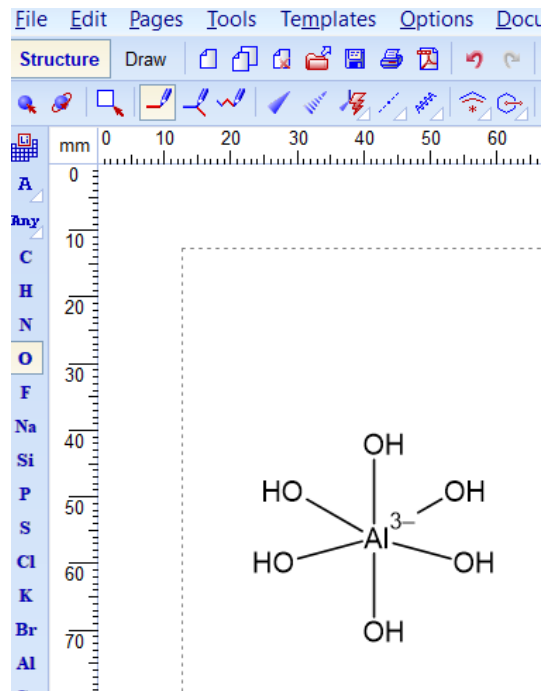

Figure 21. Replacement Al with O atoms

STEP 3

Select hydrogen atom (H) and draw two at each oxygen atom. **Figure 22.**

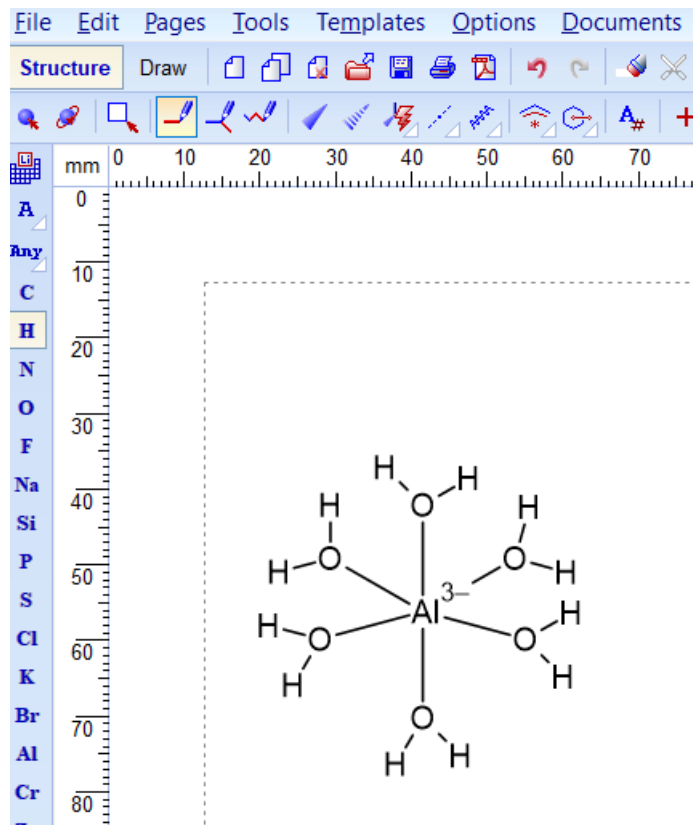

Figure 22. Adding hydrogen atoms

STEP 4

Selecting proper charge for aluminium. Select *Atom properties* (left side toolbar) and change charge. **Figure 23.**

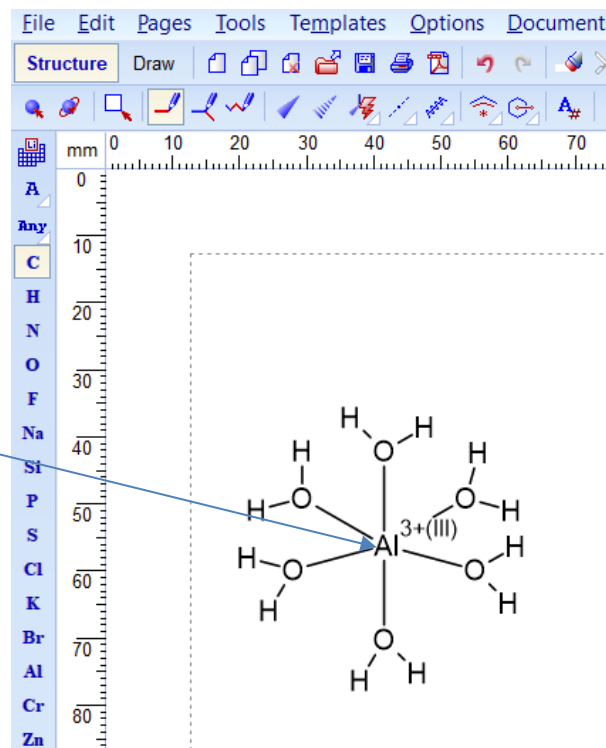
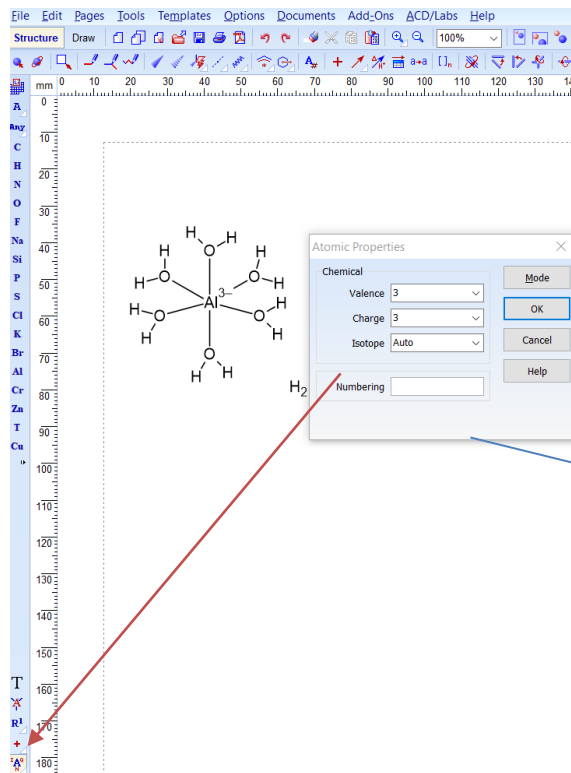



Figure 23. Adding proper charge for Al

STEP 5

Clean structure by using  **Figure 24.**

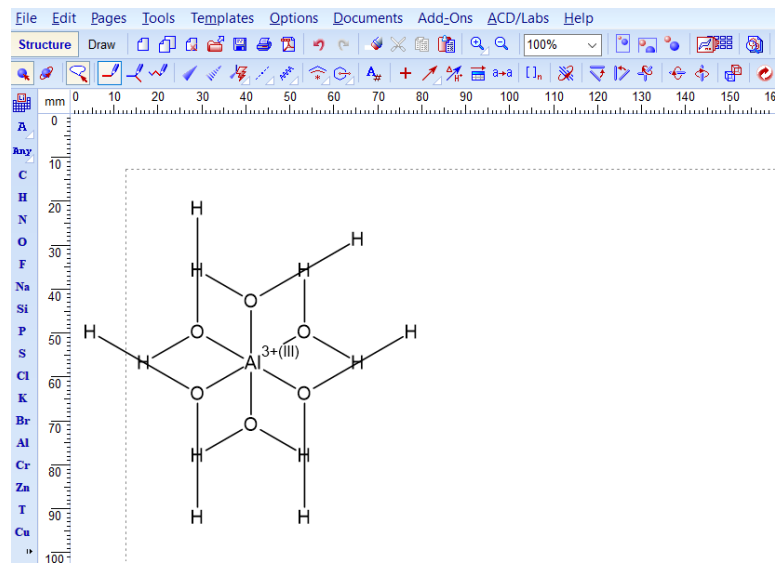



Figure 24. Structure after editing

STEP 6

Display the resulting structure in three dimensions by first selecting it and then clicking on the option  on the toolbar. A new window (*3D Viewer*) will open with a 3D view of the molecule. **Figure 25a and 25b.**

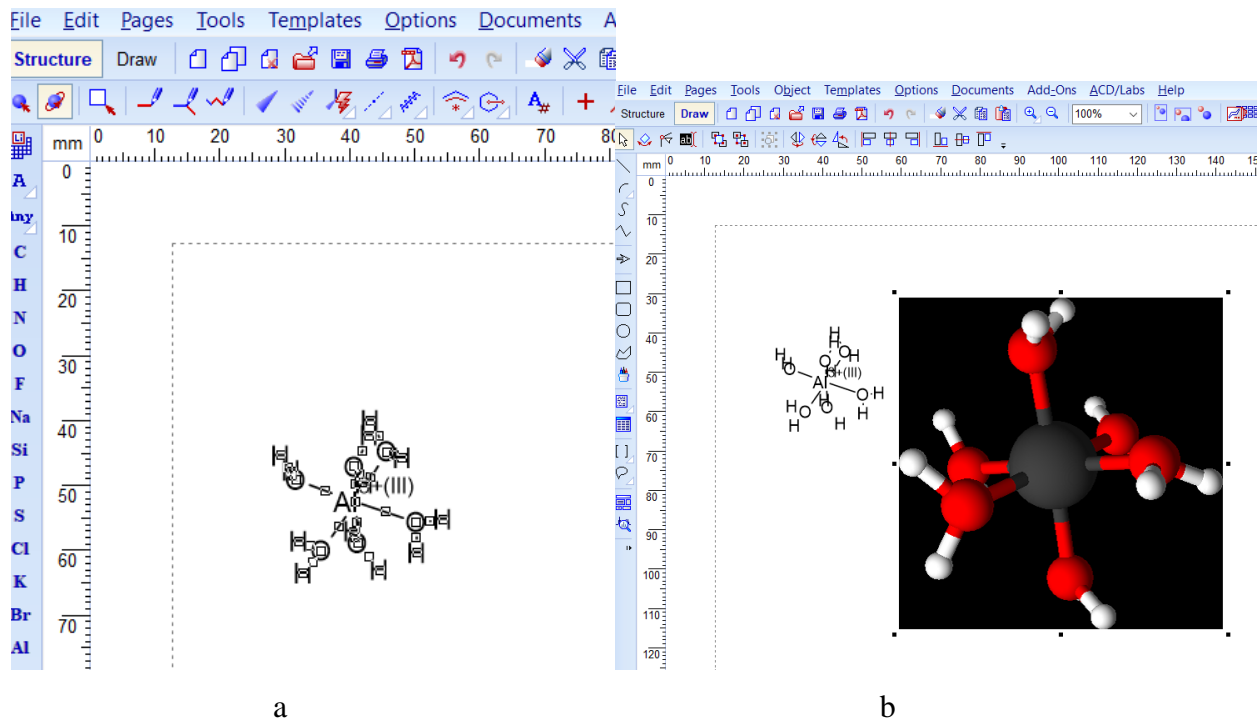

Figure 25. a) Optimised structure b) 3D structure of the compound

1.4. Examples of Tasks for Processing Teaching Content

1. Find an example of a coloured coordination ion. Draw it. Describe its structure and give the coordination number. State the type of ligand (monodentate, etc.) Then represent this compound in 3D, optimize it and save it on the computer.
2. Explore the applications of coordination compounds in everyday life. Select one molecule to display in the *ChemSketch* program. Write in your notebook the application of the chosen compound in everyday life.
Save the optimized 2D and 3D structure of these molecules to your computer.
3. Draw an example of a bidentate ligand for example 1,2-diamminethanedichloroplatinum(II).

1.5. Examples of Students Evaluation Tasks

1. Draw the following compound: $[\text{Pt}(\text{NH}_3)_2\text{Cl}_2]$ and its geometric isomer. Name both isomers and type of the ligands and do the following with it:

- display the structure of the compound in the *3D Viewer*,
- display the structure of the compound in the *3D Viewer* using sticks and balls,
- determine the bond angle between atoms,
- save both the 2D and 3D structure of the compound to the computer desktop.

2. Draw the following compound $[\text{AuCl}_2\text{Br}_2]^-$. Determine whether this ion has geometric isomers. If there are, draw them and display the structure in the *3D Viewer*.

DRAWING APPARATUSES

1.) ELABORATION OF THE UNIT TITLE

Teaching unit: Drawing Apparatuses
Unit title: Rotary Vacuum Evaporator
Estimated number of hours: 2

1.1. Theoretical introduction

Evaporation is a process in which a liquid substance is transformed into a gaseous one. This is used, for example, to dry a solid substance, to separate a liquid from a solution in so-called evaporators. A rotary vacuum evaporator (rotavap) is a laboratory device used to quickly evaporate a large amount of solvent and obtain a solid or non-volatile liquid substance dissolved in it. Rotary vacuum evaporators are complex laboratory apparatuses consisting of a condenser, a rotating evaporating flask, a receiving flask, a drive motor, a holder for positioning the apparatus and an electric heating bath. A vacuum pump is connected to put the system into reduced pressure. The rotavap is primarily used for simple and vacuum distillation, crystallization, drying, evaporation, or concentration. Typical laboratory rotavap is shown in the **Figure 1**.



Figure 1. Laboratory rotavap

1.2. Educational Outcomes

- use pre-available templates in the ChemSketch program for drawing different apparatuses
- arrange, rotate and move parts of the drawn apparatus
- save the drawn apparatuses on the computer

1.3. Instructions for Using the *ChemSketch* Program

STEP 1

Firstly, we will get to know the software properties. Switch to *Draw* mode and select *Open Template Window*. The mentioned procedure is shown in **Figure 2**.

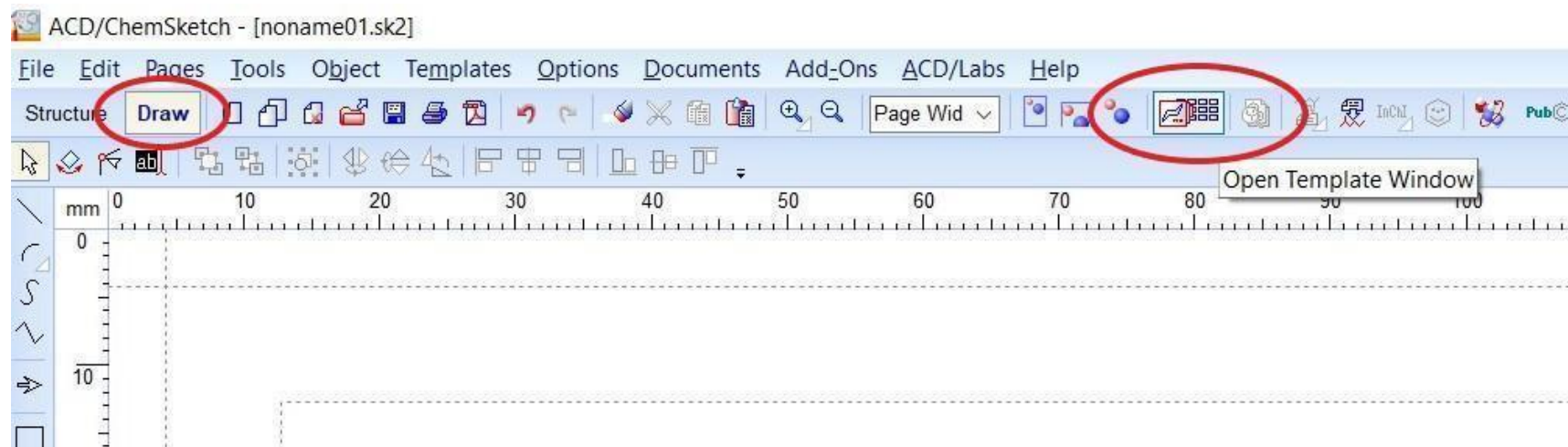

Figure 2. First step in *ChemSketch* software (Lab Kit)

In *Lab Kit*, choose glassware needed to assemble the apparatus chosen, start with round necked flasks, then splash guard, a Graham condenser and a reducing adapter. Use *ESC* to remove the object chosen! **Figure 3** shows the selection of laboratory kit and the movement in the menu.

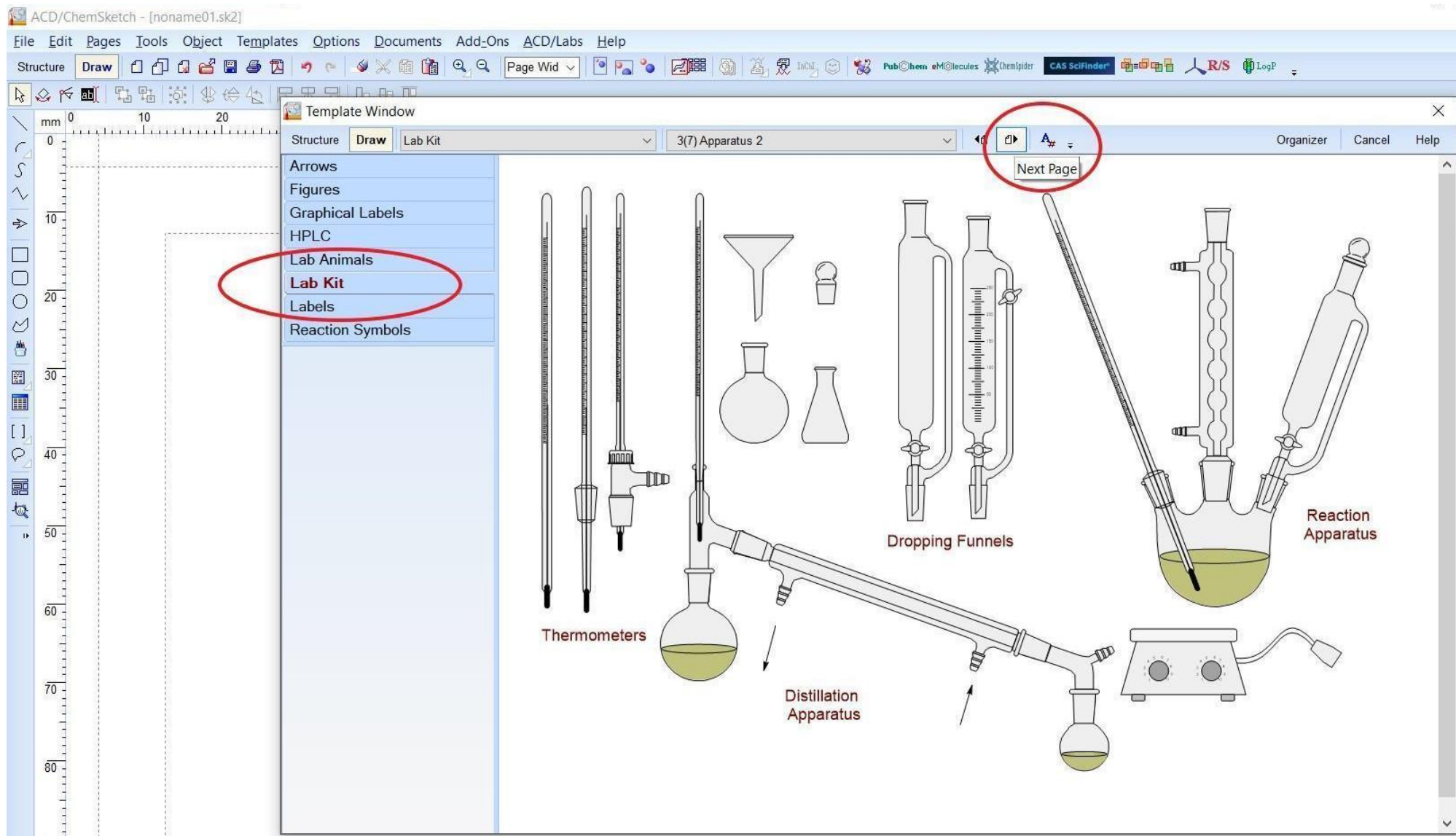

Figure 3. Lab kit

The *Arrows* option is possible to use to show the direction of rotation (**Figure 4**).

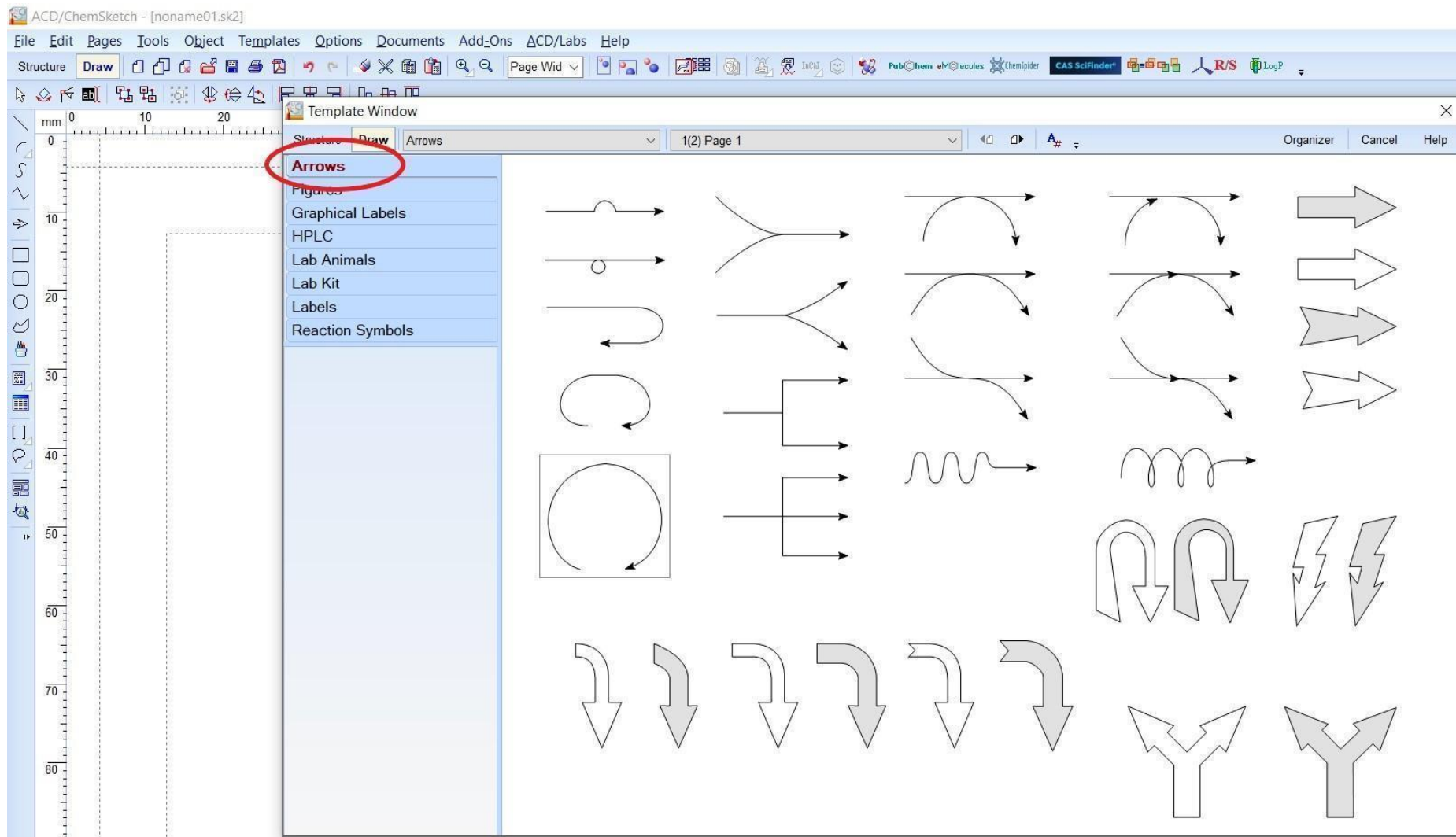



Figure 4. Arrows

Rotating or flipping the selected object is possible using the function in the upper left corner . **Figure 5** shows these options.

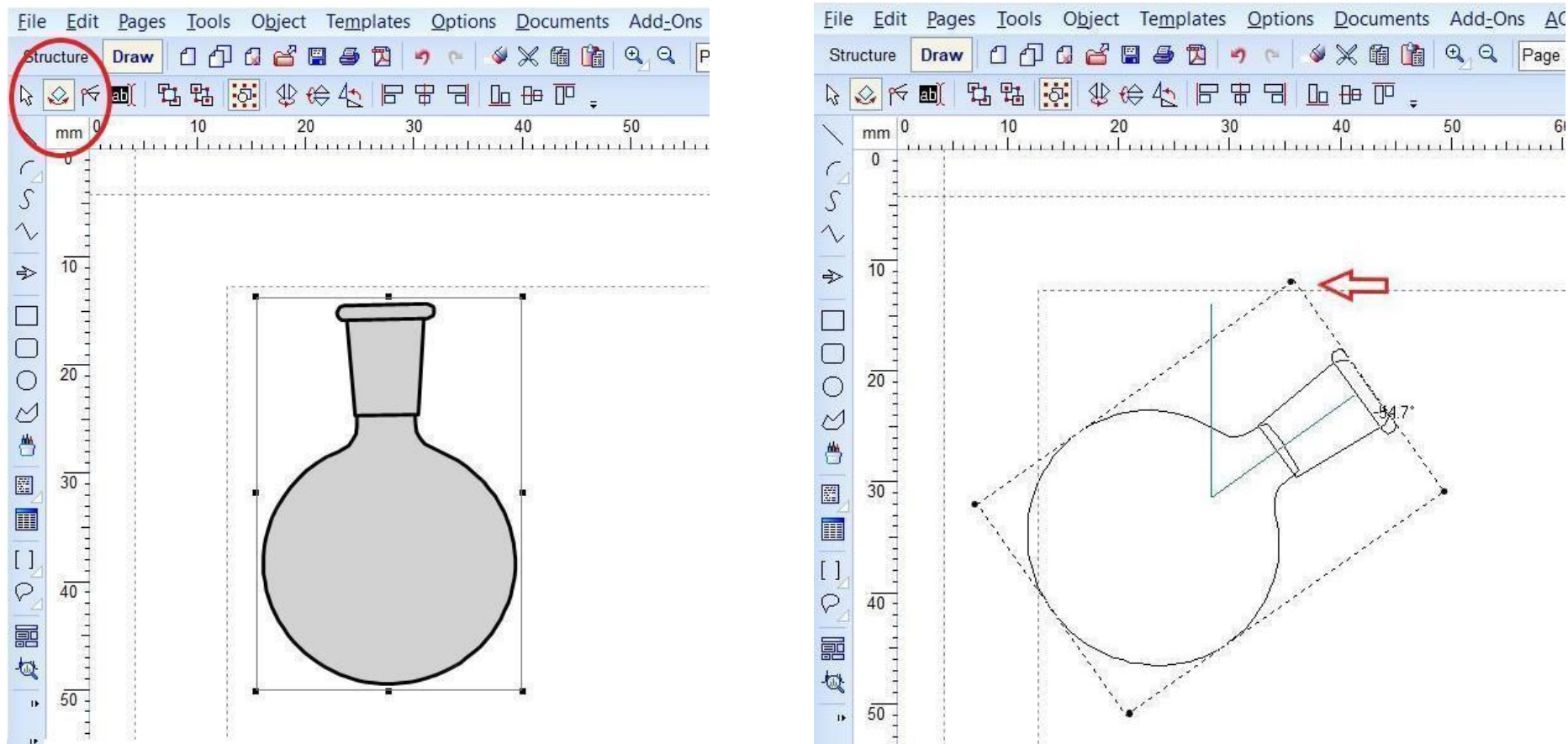

Figure 5. Rotating or flipping of selected object

To change the surface color of the selected object, it is possible to use the color palette, which is located in the left part of the lower status bar (**Figure 6**).

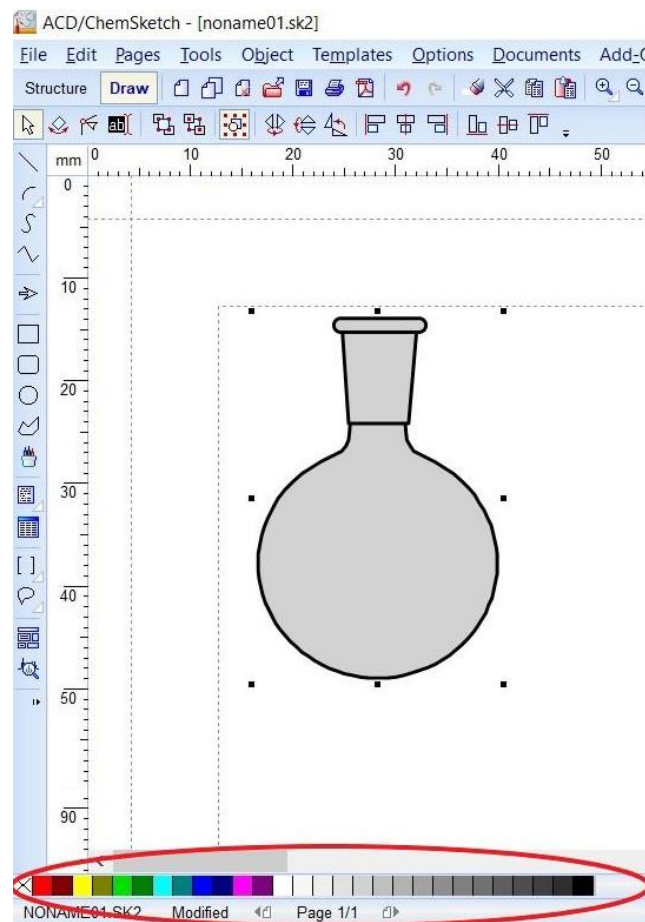

Figure 6. Change of surface color

If we right-click on the selected object, a menu appears showing what we want to do with the selected object. If we select the *Object Properties* item, we can change the color of the contour line or its thickness and design (solid line, dashed). It is shown in **Figure 7**.

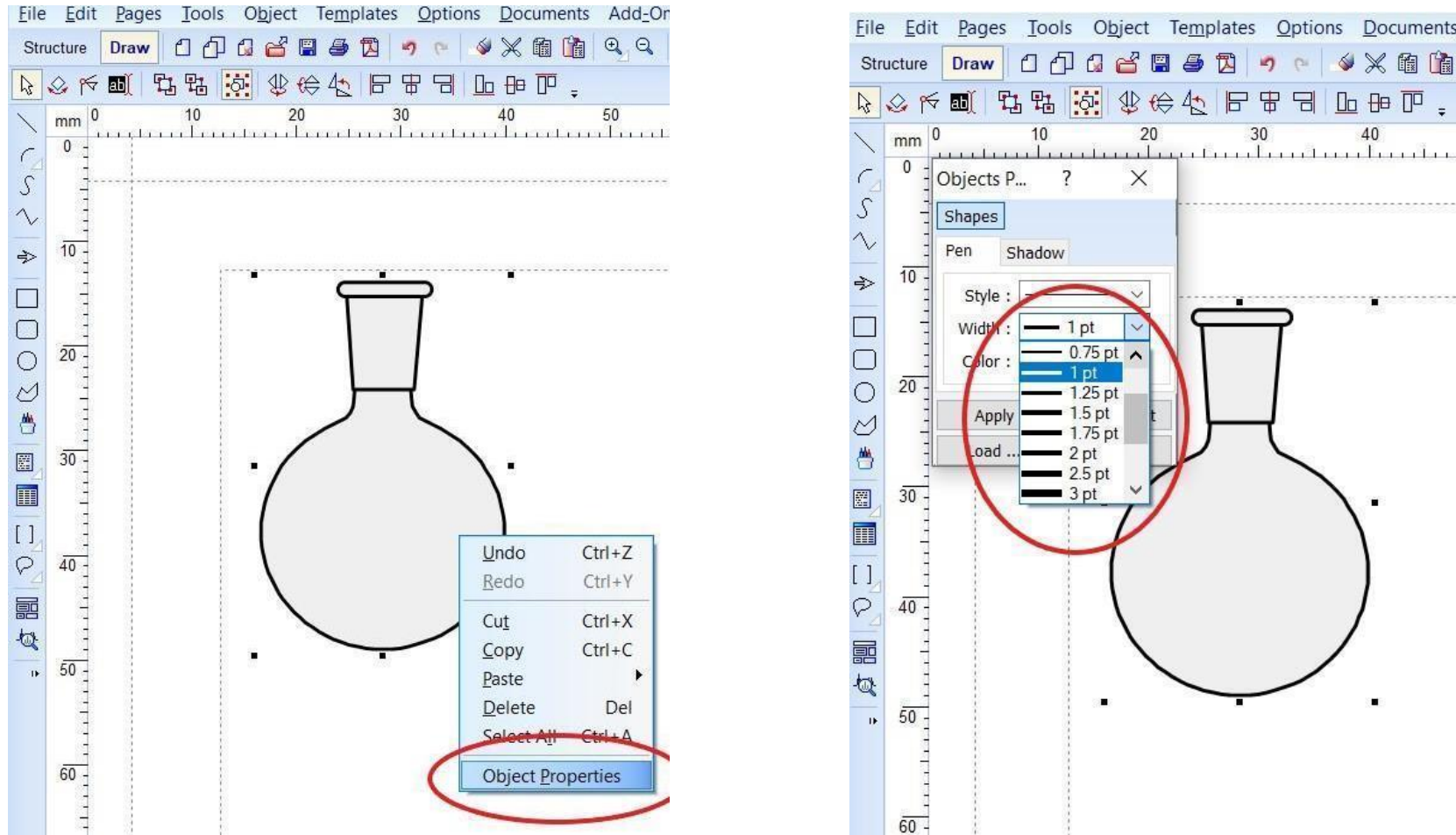

Figure 7. Change of object properties

Parts of the apparatus that are not standardized and therefore cannot be found in the menu (e.g., stands, holders etc.) can be represented using geometric shapes in the sidebar menu, which is shown in **Figure 8**.

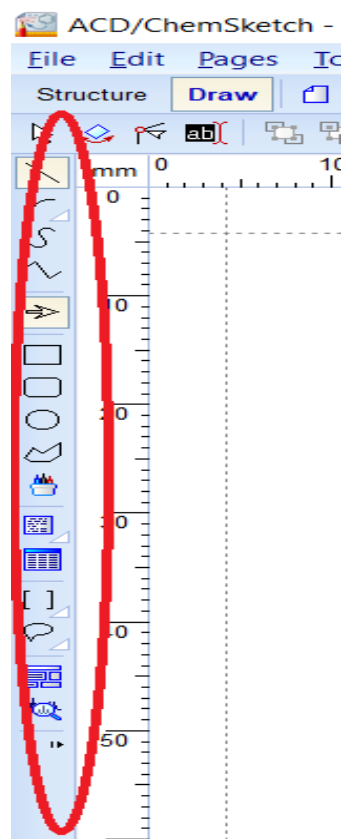

Figure 8. Sidebar menu in *ChemSketch* software

By inserting simple shapes, you can build, for example, a water bath, which can also be found in the design of our equipment. It is also possible to change the color and thickness of the line for objects and shapes inserted in this way – as in **Figure 9**.

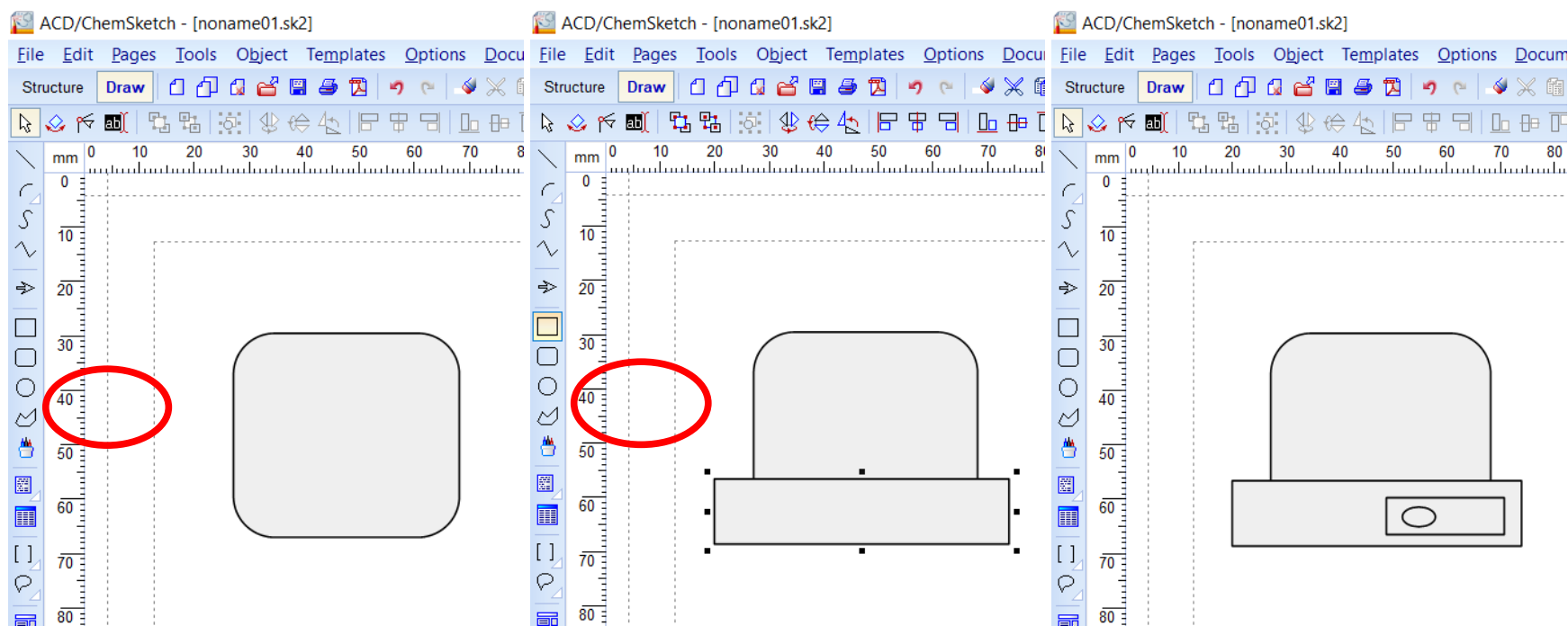

Figure 9. Creating of nonstandard shapes of apparatus parts

As a part of the creation of laboratory reports, it is also necessary to insert the names of the individual objects that make up the apparatus. The procedure is simple - either we can use the same menu and the same way as we use for laboratory glassware, or we can insert a text field and add the name manually. The mentioned procedure is shown in **Figure 10**.

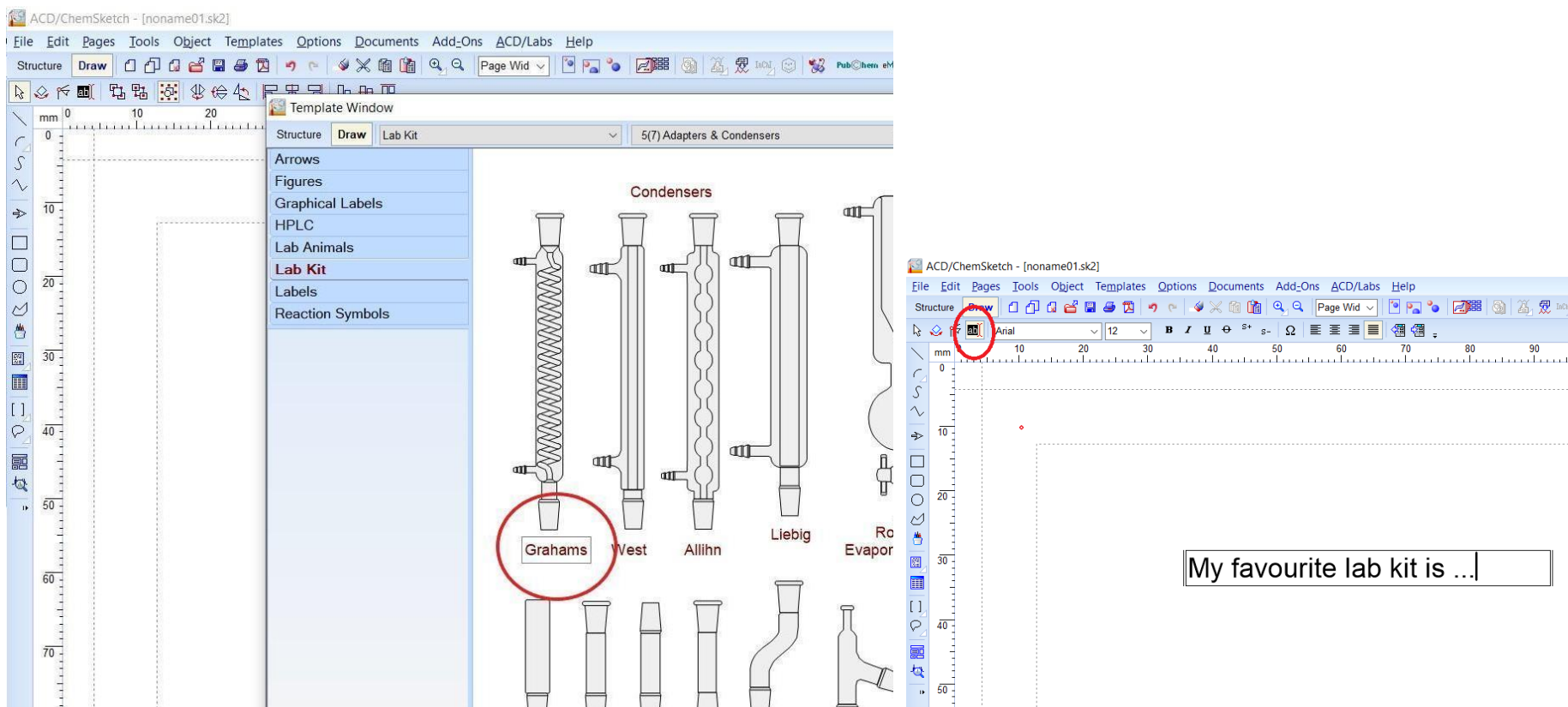

Figure 10. Enter the name of the objects

The individual items which we create the apparatus from can be moved to the foreground or background, according to current preferences. We use the *Bring to Front* or *Send to Back* buttons as shown in **Figure 11**.

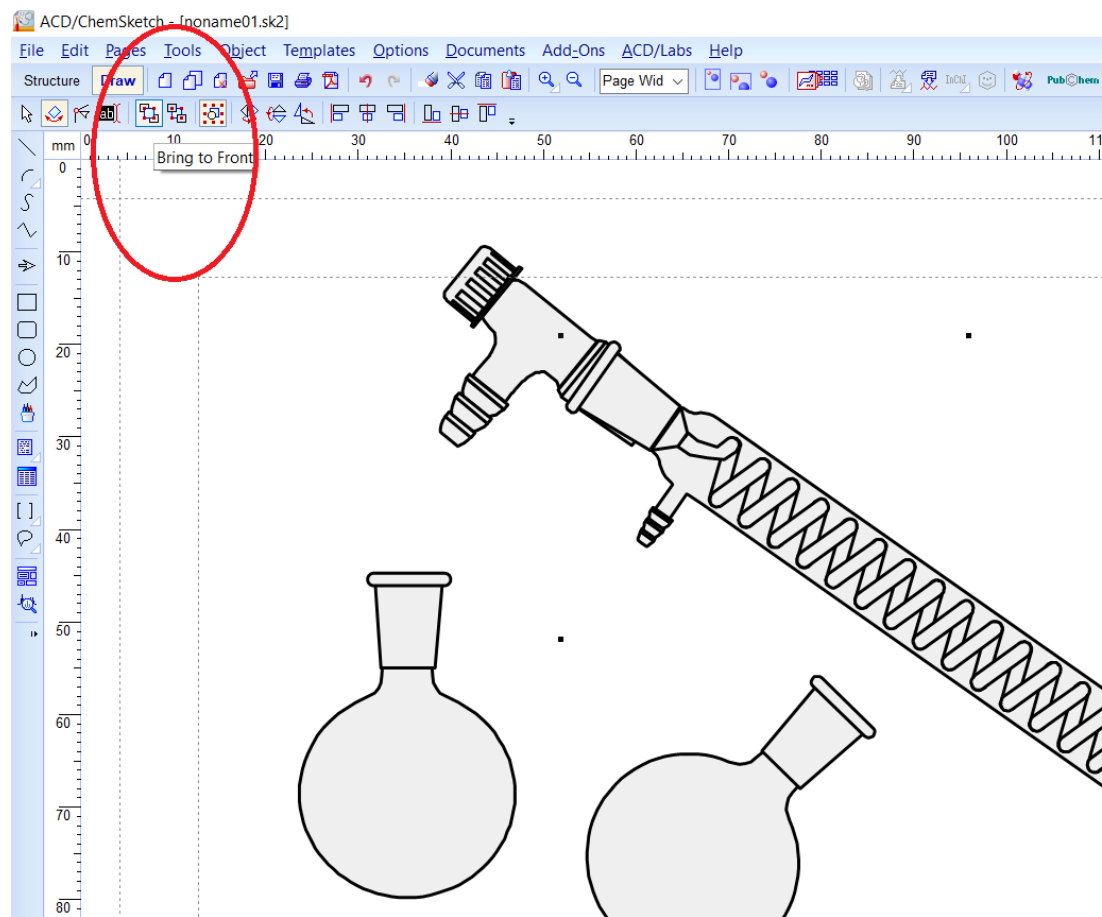

Figure 11. Moving an object to the foreground or background

Saving the work is possible in several ways - for further editing, it is necessary to save the work as a *ChemSketch* *.sk2 workbook. To use it, for example, in the laboratory reports, we can save the work in e.g. jpg format – these options are mentioned in **Figure 12**.

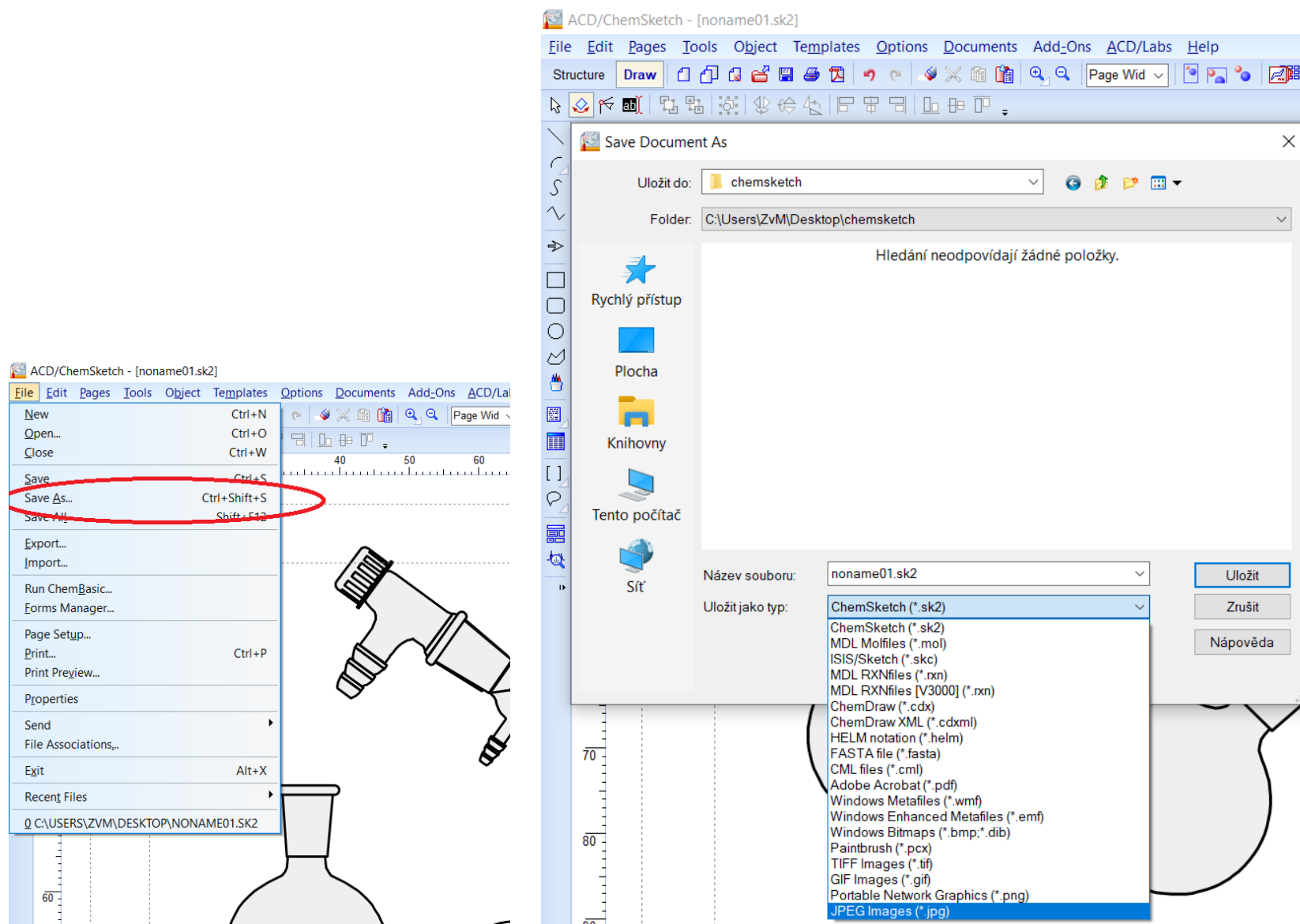

Figure 12. Options for saving projects in *ChemSketch* software.

STEP 2

In this step we will move on to assembly of the rotary evaporator. According to the previously described steps, select the appropriate laboratory kit and connect it as you see in **figure 13**.

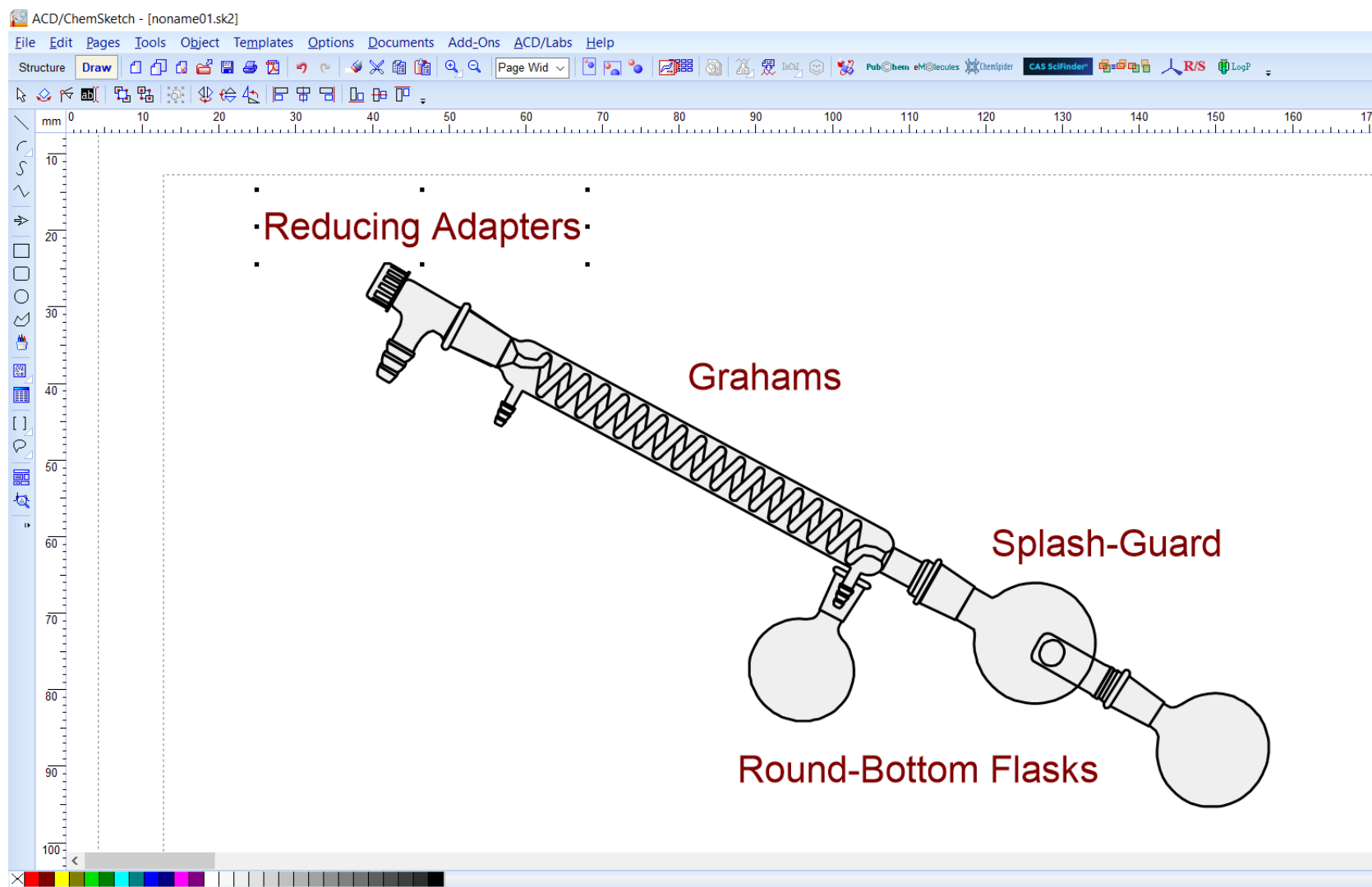

Figure 13. Laboratory kit used for creating rotary evaporator

STEP 3

Create with the help of the side sheet and with help of following **Figure 14** the lower part of the evaporator, which shows the water bath and its control.

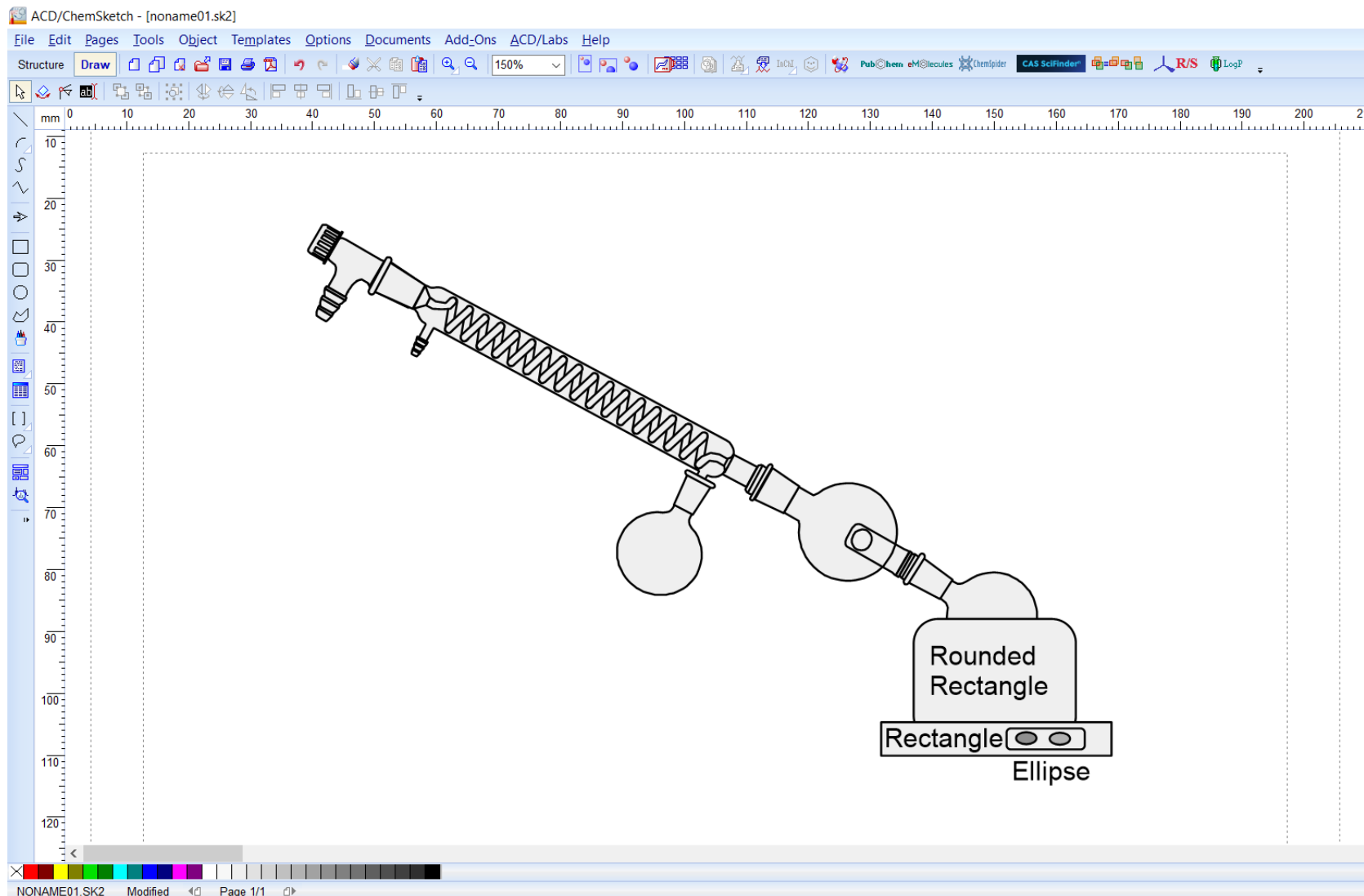

Figure 14. Creating the water bath for the evaporator

STEP 4

In the next step, draw the holder, the stand and use the arrow to show direction of movement of evaporator rotation as in **Figure 15**.

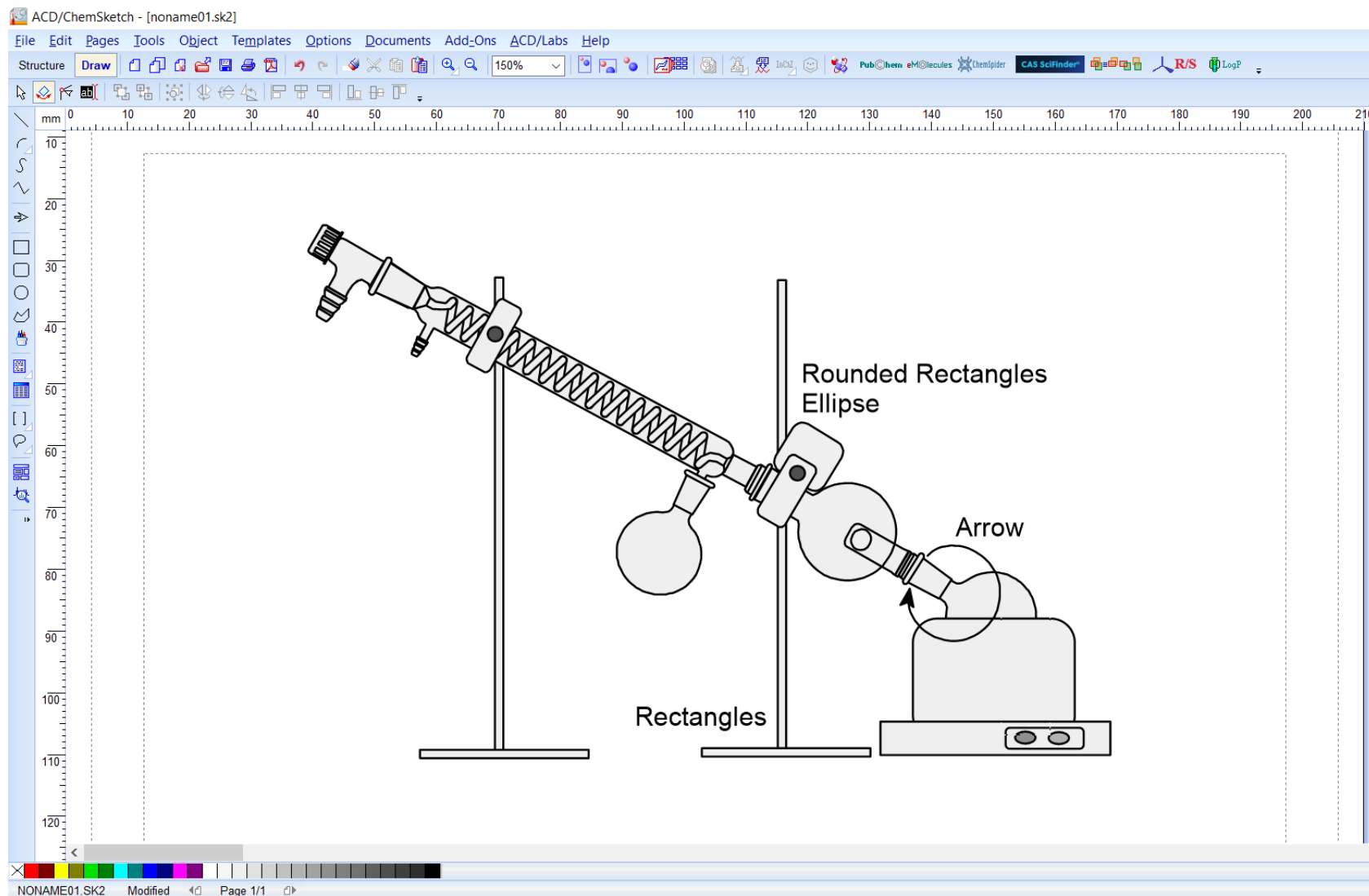

Figure 15. Completing the schema of rotary evaporator with additional equipment

STEP 5

Final look of the designed rotary evaporator apparatus is shown in **Figure 16**.

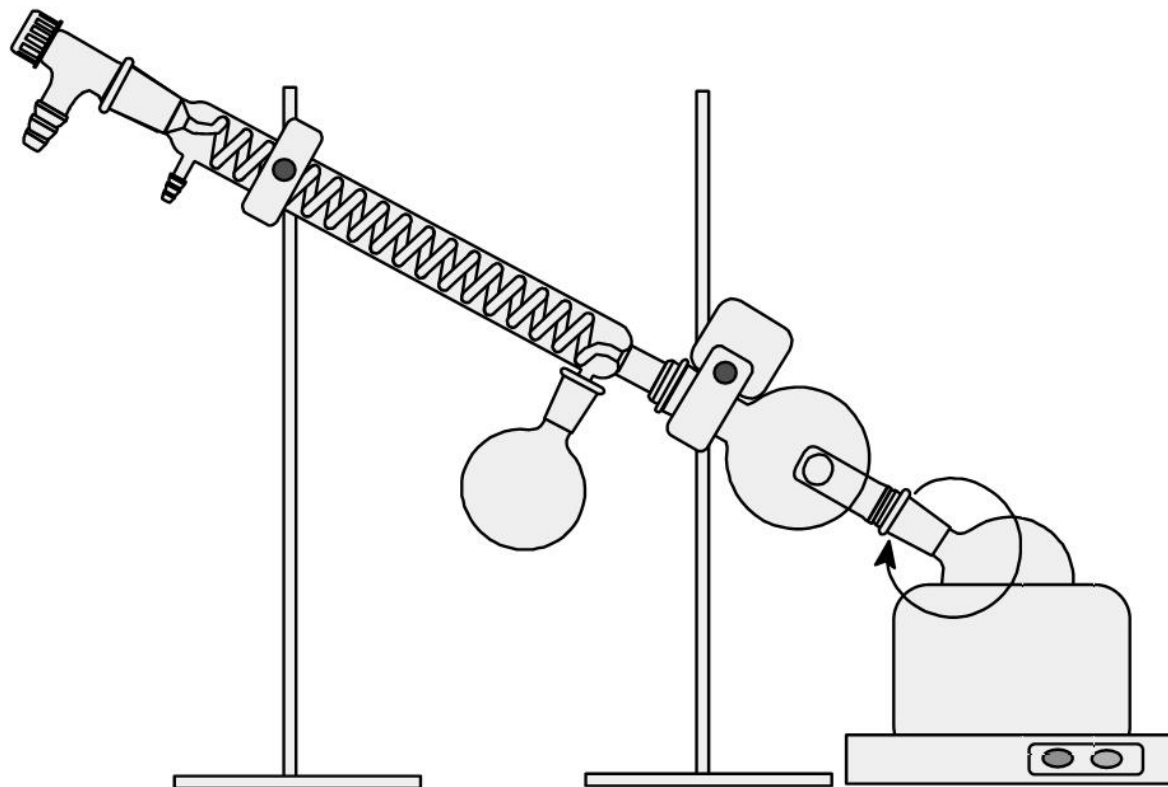

Figure 16. Final look of rotary evaporator created in *ChemSketch* software

EXAMPLE 2

Filtration apparatus

STEP 1 Choose Stand from the *LabKit*.

STEP 2 Add clamps as it is shown in **Figure 17**.

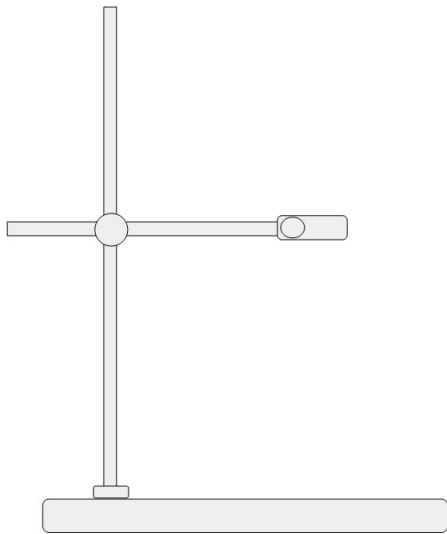

Figure 17. A stand and clamps for a filtration apparatus

STEP 3 Place a filtration funnel on the end of the clamps.

STEP 4 Place a beaker under a funnel (a funnel stem has to be inside the funnel) as shown in **Figure 18**.

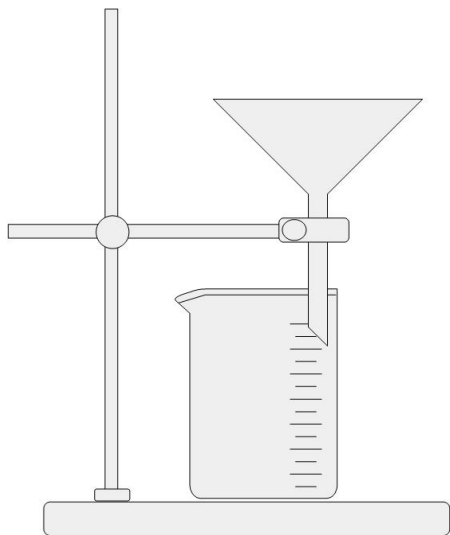

Figure 18. Placement of the funnel and the beaker

STEP 5 Finally, place a beaker and a glass rod above the funnel at the right angle. **Figure 19**

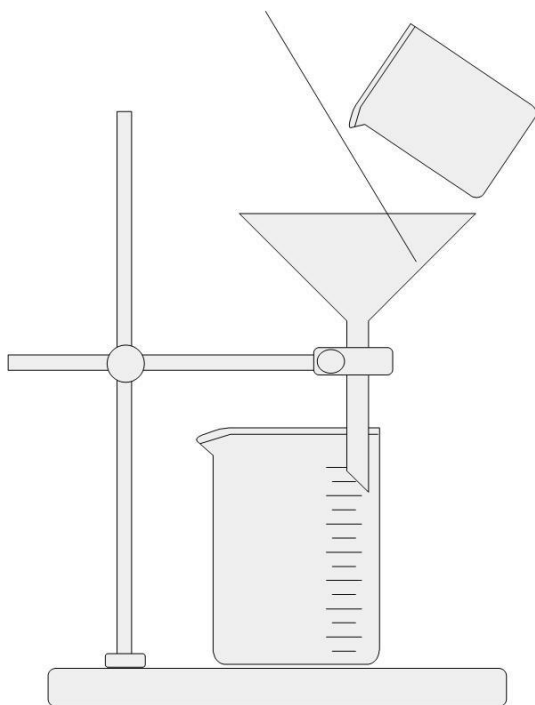

Figure 19. Completion of the filtration apparatus

1.4. Examples of Tasks for Processing Teaching Content

Find industrial uses of distillation columns in oil processing. Focus on the technology, try to imagine the individual parts of industrial oil processing and use *ChemSketch* to draw a part of the oil processing process.

Place the individual parts of the distillation column on a free page of the *ChemSketch* program and try to name the individual parts.

Then connect all the parts and line them up neatly.

Compare the result of your work with the assignment and consult the result with the lecturer.

1.5. Examples of Students Evaluation Tasks

Create and design a simple distillation apparatus.

Name the individual parts of the technological scheme and explain their principle and use in distillation.

Assemble and align all parts.

Describe the distillation process and discuss the results of your work with your tutor.

LITERATURE

1. Ribarić N.; Futivić I.; Sakač N., Kemija 4 udžbenik za četvrti razred gimnazije. 2. izdanje. Zagreb. Alfa d.d., 2016.
2. Wade, ml., L. G., Organska kemija, 7. izdanje (englesko), 1. izdanje (hrvatsko). Zagreb. Školska knjiga, 2017.
3. ACD/ChemSketch, Version 11.0 for Microsoft Windows, Tutorial Drawing Chemical Structures and Graphical Images
4. A. Habuš, M. B. Tominac, S. Liber, D. Bajić, Kemija 2, udžbenik kemije za drugi razred gimnazije, Zagreb, Profil Klett, 2020.
5. [https://chem.libretexts.org/Courses/Purdue/Purdue_Chem_26100%3A_Organic_Chemistry_I_\(Wenthold\)/Chapter_03%3A_Structure_of_Alkanes/3.4.%09Structure_and_Conformations_of_Alkanes/3.4.1._Newman_Projections](https://chem.libretexts.org/Courses/Purdue/Purdue_Chem_26100%3A_Organic_Chemistry_I_(Wenthold)/Chapter_03%3A_Structure_of_Alkanes/3.4.%09Structure_and_Conformations_of_Alkanes/3.4.1._Newman_Projections) - pristupljeno 17. travnja 2023.
6. A. Habuš, M. B. Tominac, S. Liber, D. Bajić, Kemija 3, udžbenik kemije za treći razred gimnazije, Profil Klett, 2020.
7. Barić Tominac, M., Habuš, A., Liber S., Vladušić R. (2019.): Kemija 1, udžbenik kemije za prvi razred gimnazije, Zagreb, Profil Klett
8. Blagović, B. (2018.): Kemija u nastavi, Sveučilište u Rijeci, Medicinski fakultet
9. Mareček, A., Honza, J. Chemistry for four-year high schools, volume 3. 1st ed. Olomouc: Nakladatelství Olomouc 2000. 250 pp. ISBN 80-7182-057-1
10. A. Kornhauser: Organska kemija II, 11.izdaja, DZS, 2000
11. A. Smrdu: Kemijo razumem, kemijo znam 3, Naloge iz kemije za 3. letnik gimnazije, II. Izdaja, Jutro, 2020;
12. A. Smrdu: Snov in spremembe 2, III. izdraja, Jutro, 2012
13. A. Smrdu: Snov in spremembe 3, II. izdaja, Jutro, 2010;
14. F .Lazarini, J .Brenčić, Splošna in anorganska kemija, 3.izdaja 2. natis, FKKT, 2014
15. <https://www.appletonwoods.co.uk/product/rotary-evaporator-complete-with-glass-set-00-stuart/>
16. J. C. Kotz, P. Treichel: Chemistry and Chemical Reactivity, 3rd edition, Harcourt College Pub, 1995
17. M.Tišler: Sporočilnost molekul, DZS, 1998
18. Paulová, H., Dostál, J., Králíková,, M., Peš, O., Slanina, J., Táborská, E. and Tomandlová, M. Biochemistry for non-medical medical disciplines, 1. st ed. Brno: Publisher Masarykova univerzita 2021. 154 s. ISBN 978-80-210-9858-9
19. Predmetni izpitni katalog za splošno maturo iz kemije, RIC, 2021
20. www.britannica.com/science/coordination-compound, pridobljeno: 13. 2. 2023

21. www.unacademy.com/content/cbse-class-12/study-material/chemistry/uses-of-aldehydes-and-ketones/

22. www2.chemistry.msu.edu/faculty/reusch/virttxtjml/aldket1.htm